

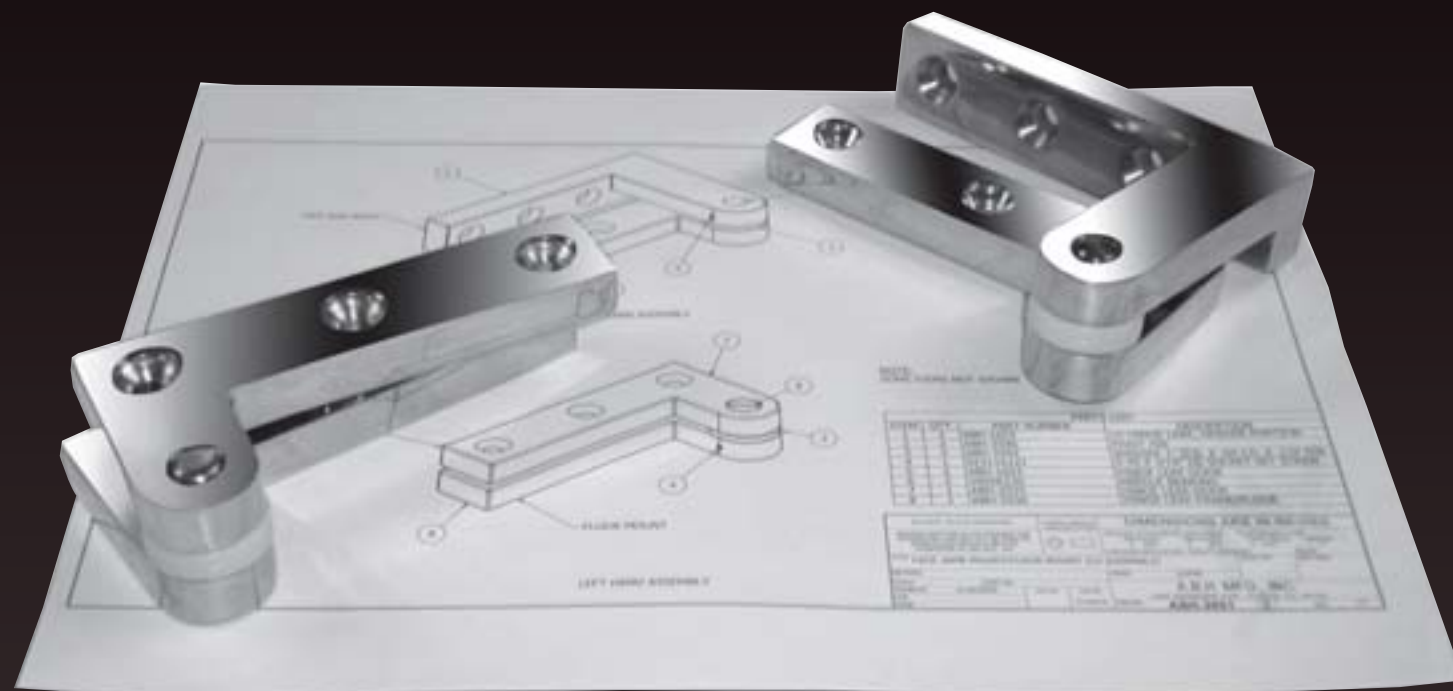

ABH offers a variety of custom hardware options and finishes for many different applications. Contact our factory for additional information.



From concept to creation, we support you every step of the way with our talented designers, custom fabricators and unparalleled customer service.

ARCHITECTURAL BUILDERS HARDWARE MFG., INC.

1222 Ardmore Ave.
Itasca, IL 60143

P: (630) 875-9900
F: (800) 932-9224
E: abhinfo@abhmfg.com



WWW.ABHMFG.COM



ABH
Manufacturing Inc.

- Overhead Holders & Stops
- Hospital Push/Pull Latches
- Electromagnetic Door Holders
- Pivots & Pivot Sets
- Aluminum Continuous Hinges
- Stainless Steel Pin & Barrel Hinges
- Stainless Steel Edge Guards
- Power Transfer/Electrified Hardware
- Rescue Hardware
- Flush Bolts & Coordinators
- Auxillary Locking Hardware
- Custom Strikes



Custom Pivots

ABH CUSTOM PIVOTS

STAINLESS STEEL BASE MATERIAL

TOP JAMB PORTION

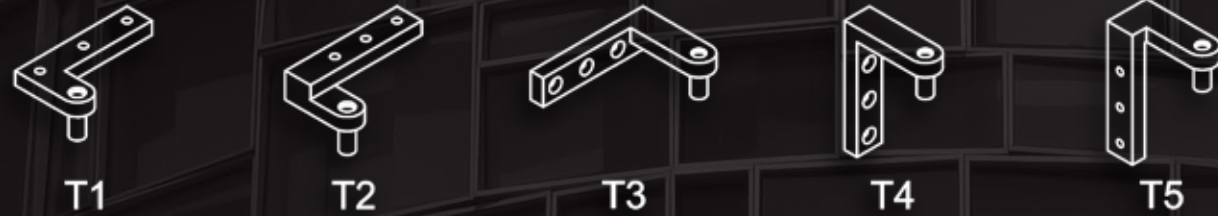

DOOR PORTION



CENTER HUNG PIVOT



BOTTOM JAMB OR FLOOR PORTION



Pivot Sets



Overhead Stops



Custom Pivots



ABH CUSTOM PIVOT SETS

- ABH custom pivot sets can be ordered in any combination of top jamb portion, door top portion, door bottom portion and bottom jamb or floor portion.
- Pivots in certain configurations can also be used as intermediate offset pivots. Intermediate Pivots are used for extra support in situations which require tall or heavy doors. They can also be configured for use with Dutch Doors.
- All pivot portions are made of (1/2") thick x (1") wide stainless steel material.
- All fasteners are stainless steel.
- Needle bearings provided standard.
- Standard BHMA color matches available in US3, US4, US10, US10B, US32, US32D.
- Contact factory for custom finishes.



Requirements:

- Configuration
- Offset
- Finish
- Door Thickness
- Clearances



MAKES LIFE SIMPLE