

## Quartztone® Undermount 60/40 Double Bowl Model P-175U



P-175U

### FEATURES

- 80% quartz and granite
- 9-1/2" depth
- Intrinsically hygienic Non-porous surface
- Antibacterial protection with silver ion Microstop®
- Silky to the touch, 3 times harder than natural granite
- Food-safe, UV-stable-will not fade • Color-fast throughout
- Heat resistance to +500°F
- Highest resistance to thermal shock, scratches and chips
- Ariapure® features odor and pollutant disinfection
- Fits 36" sink base
- Supplied with cutout template, fasteners and instructions
- 1 year Limited Warranty

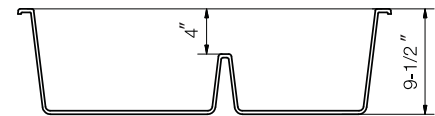
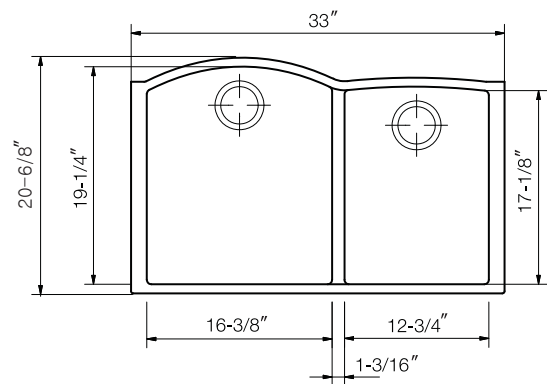

### OPTIONAL COLORS



Midnite Metallic    Mocha Solid    Taupe Structured    Sand Solid    Cloud Solid

OVERALL DIMENSIONS	EACH BOWL	CUTOUT SIZE	PACKAGING*	WEIGHT*
33" x 20-6/8"	16-3/8" x 19-1/4" 12-3/4" x 17-1/8"	See Template	1/10 pcs.	50/540lbs.

\*Standard packaging: Single boxed /Pallet of single boxed.  
All dimensions are in inches. Specifications subject to change without notice.

### OPTIONAL ACCESSORIES

Bottom Grid: 629801 (large bowl),  
629802 (small bowl)

Strainer Options: Stainless steel strainers,  
Color strainers, Color Disposal flanges

Project/Job name \_\_\_\_\_

Architect/Engineer \_\_\_\_\_

Contractor \_\_\_\_\_

Model \_\_\_\_\_ Q'ty \_\_\_\_\_

Notes \_\_\_\_\_