

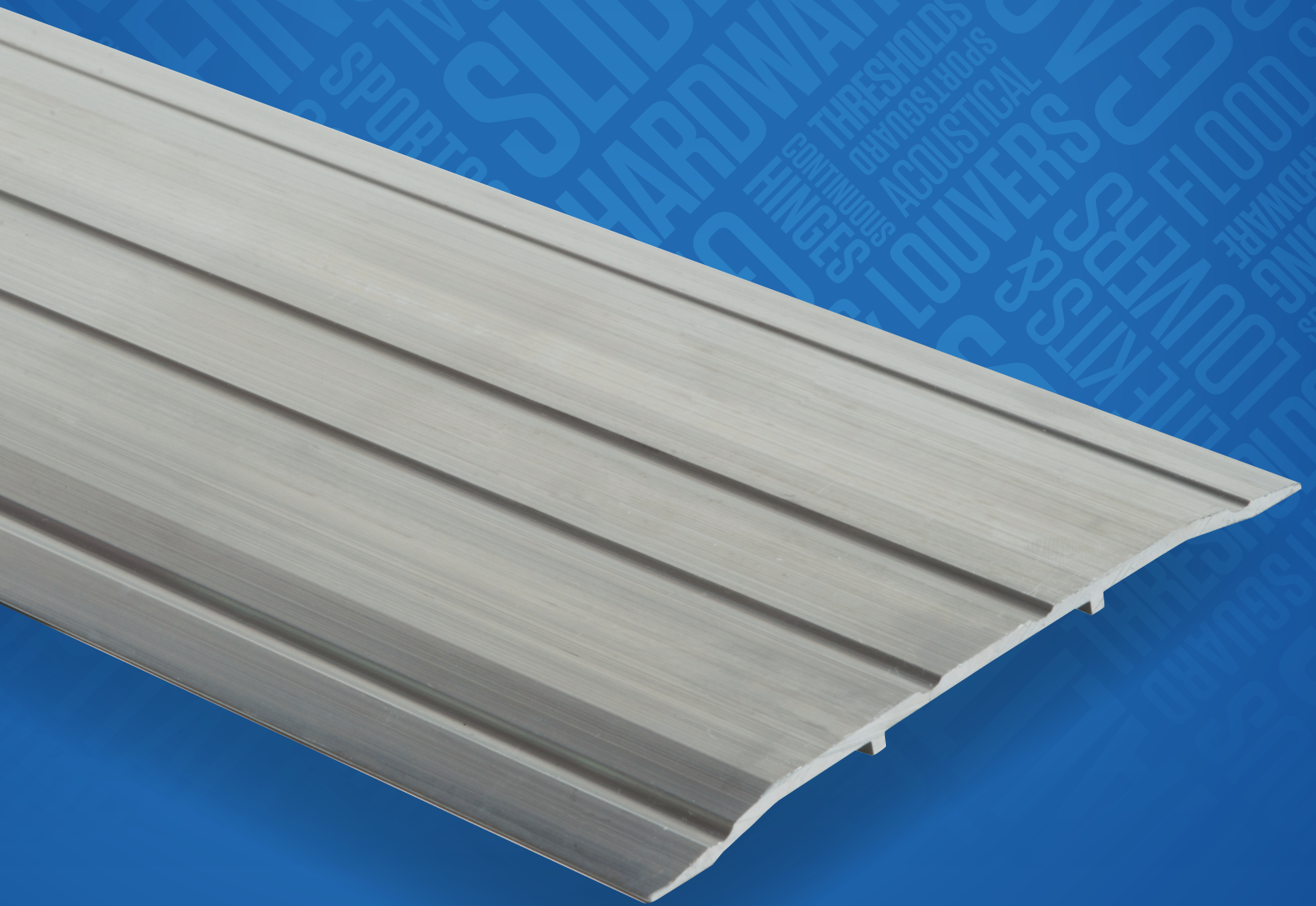

SPORTSGUARD™

— FLOORING TRANSITIONS —





TRANSITION PRODUCT INDEX:

	Page
Aluminum:	
ADA Compliant Interlocking Reducers	SG12
Aluminum Cover Plates	SG6
Architectural Bronze 1/4" Saddle.....	SG10
Architectural Bronze 1/2" Saddle	SG10
Architectural Bronze Custom.....	SG11
Custom Fabricated.....	SG7
Edge Components and Plates.....	SG8-SG9
Extended Width.....	SG4
Fasteners	SG13
Half Saddle.....	SG6
Half Saddle and Extended Width Components.....	SG5
Heavy Duty	SG3
Interlocking Rubber Reducers	SG12
Offset	SG6
Return Closed Ends.....	SG7
Return Closed Ends for Reducers.....	SG12
Saddle	SG2
Sports Floor Assemblies.....	SG7
Stainless Steel 1/4" Saddle.....	SG10

RATING SYMBOLS LEGEND



ADA COMPLIANT Barrier Free Transitions meet the requirements of ADA Standards for Accessible Design and ICC/ANSI A117.1 Accessible and Usable Buildings and Facilities.



POSITIVE PRESSURE CERTIFIED by UL to ANSI/UL10C; complies with IBC, NFPA 80 and NFPA 252 for application to Hollow Metal fire doors rated up to 3 Hrs., and Wood Fire doors rated up to 90 minutes.



CERTIFIED by UL to CAN/ULC-S104 and ANSI/UL10B; complies with NFPA 80 and NFPA 252 for application to Hollow Metal fire doors rated up to 3 Hrs., and Wood fire doors rated up to 90 minutes.



Air Infiltration Tested to ASTM E283, Standard Test Method for Determining Rate of Air Leakage Through Exterior Windows, Curtain Walls, and Doors.



SLIP-RESISTANT 'SIA' textured surface is available on all transitions. Our process embeds and fuses bits of hot nickel and titanium into the surface of the transition. This technology originally developed for use on aircraft carrier decks is very skid resistant and will not wear off.



ANSI/BHMA CERTIFIED. Certified transitions comply with American National Standard for Transitions ANSI/BHMA A156.21 and are listed in the BHMA Certified Products Directory.



Online product listings at www.ul.com/database



MATERIALS / FINISHES

MATERIALS

- Transitions are Aluminum Alloy 6063, T5 temper, unless noted.
- Cover Plates 818, 814 and 828 are Aluminum Alloy 3003, H14 hardness.
- Cover Plate 838 is Aluminum Alloy 5052, H32 hardness.
- Architectural Bronze Transitions are Alloy CDA 385 (Copper Alloy No. C38500), Architectural Bronze.
- Brass Cover Plate 818BR is Alloy CDA 260 (Copper Alloy No. C26000) cold formed Cartridge Brass.
- Stainless Steel Transitions and Cover Plates are Type 304; known for its excellent corrosion resistance, high tensile strength and resistance to oxidation.

TRANSITION FINISHES

MATERIALS	FINISHES	ANSI/BHMA	US	NGP SUFFIX:
ALUMINUM:	MILL FINISH DARK BRONZE POLISHED SLIP RESISTANT	719 717	US27	NONE DKB POL SIA
ARCHITECTURAL BRONZE:	SATIN FINISH DARK BRONZE OIL RUBBED POLISHED SLIP RESISTANT	728 722 721	US4 US10B US3	BR BR-DKB BR-POL BR-SIA
STAINLESS STEEL:	MILL FINISH BRUSHED (#4) POLISHED SLIP RESISTANT	630 629	US32D US32	SS SS-BRUSHED SS-POL SS-SIA

SLIP RESISTANT FINISH



- SIA (Slick It Ain't) finish is our slip resistant textured surface, available on all transitions up to 24" wide and on 818 aluminum and brass cover plates up to 10" wide.
- Our SIA technology embeds bits of hot nickel and titanium into the surface of the transition using a high pressure thermo-electrostatic process. It was originally developed for use on aircraft carrier decks. SIA finish is very durable and will not wear off.
- This results in a slip resistant surface that is similar to high grit sandpaper.
- Aluminum and Stainless Steel SIA finish transitions are a pewter color.
- Architectural Bronze SIA finish transitions are a brass color.

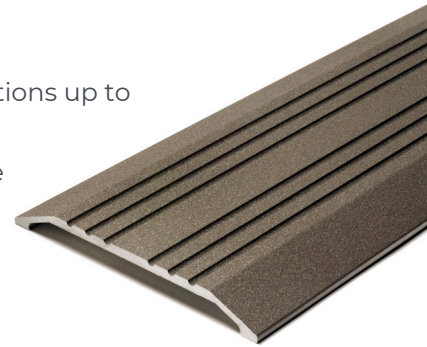

POWDER COAT FINISH

- Powder Coat finish is available on most transitions upon request. Consult factory for custom color matching.

TRANSITIONS

SADDLE

All transitions this page

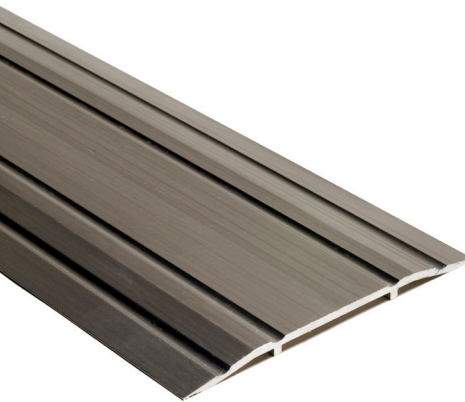

413 .53 lbs./ft.
413DKB .53 lbs./ft.

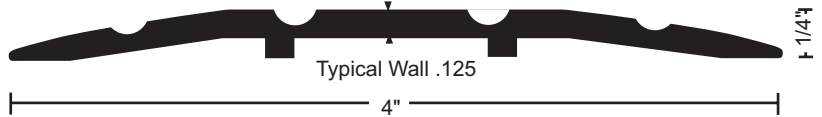

513 .68 lbs./ft.
513DKB .68 lbs./ft.

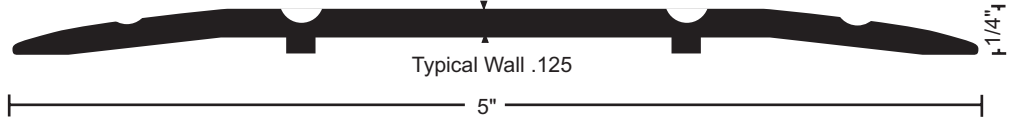

613 .88 lbs./ft.
613DKB .88 lbs./ft.

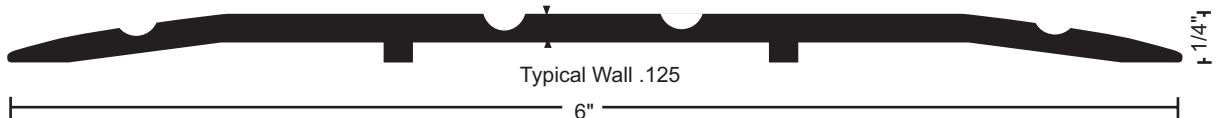

TRANSITION	WIDTH
413, 413DKB, 413BR	4"
513, 513DKB, 513BR	5"
613, 613DKB, 613BR	6"
713, 713DKB, 713BR	7"
813, 813DKB, 813BR	8"
913, 913DKB	9"
1013, 1013DKB	10"

NOTE: Flute pattern varies with width of transition

MATERIALS & FINISHES

- Aluminum Mill (Standard)
- DKB - Aluminum Dark Bronze
- BR - Architectural Bronze



Optional:
Slip Resistant
SIA Finish

FASTENERS

- #10 x 1-1/2" FH zinc plated wood screws furnished.
- Dark bronze supplied with DKB transitions.

NOTE: Transitions supplied with holes down the center. Specify NO HOLES for blank material.

TRANSITION	WIDTH
425E, 425EDKB	5"
426E, 426EDKB	6"
427E, 427EDKB	7"
428E, 428EDKB	8"
429E, 429EDKB	9"
430E, 430EDKB	10"

NOTE: Flute pattern varies with width of transition

424E .60 lbs./ft.
424EDKB .60 lbs./ft.



425E .80 lbs./ft.
425EDKB .80 lbs./ft.

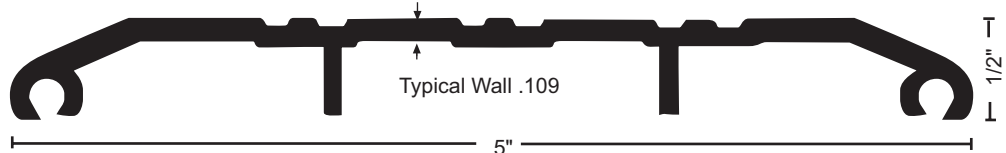

VINYL FOOT SEAL OPTION:

- Used instead of caulking to increase the weather resistance of the transition. Specify on order.

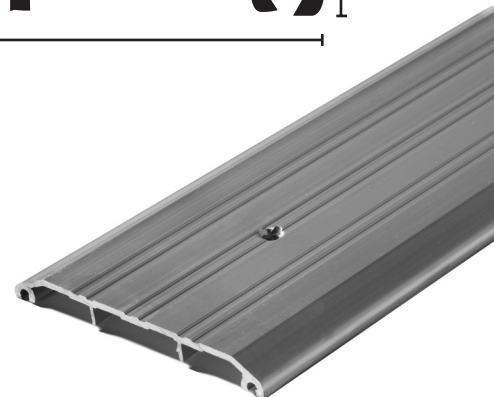

TRANSITIONS

HEAVY DUTY

- For use where forklift or vehicular traffic occurs
- Recommended for delivery/storage doorways where heavier loads travel
- BHMA certified to ANSI A156.21 Heavy Duty 10,000 lb. load test
- Optional "SIA" slip-resistant finish recommended in moisture prone areas

All transitions this page



Optional:
Slip Resistant
SIA Finish

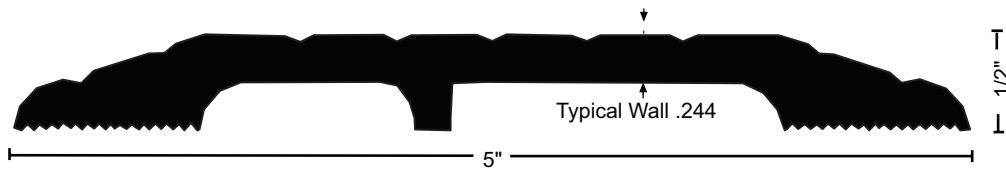

425HD 1.6 lbs./ft.
425HDDKB 1.6 lbs./ft.

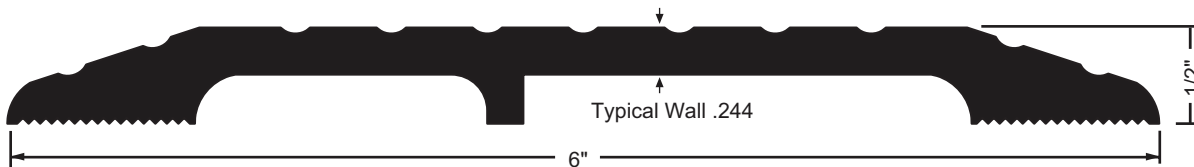

426HD 1.98 lbs./ft.
426HDDKB 1.98 lbs./ft.

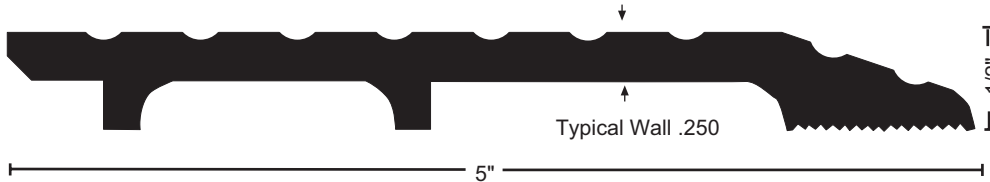

325HD 1.65 lbs./ft.
325HDDKB 1.65 lbs./ft.

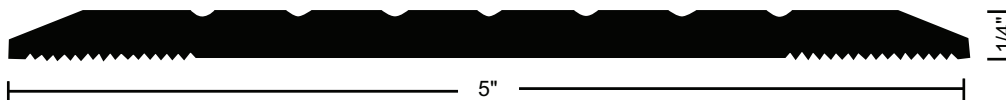

513HD 1.4 lbs./ft.
513HDDKB 1.4 lbs./ft.

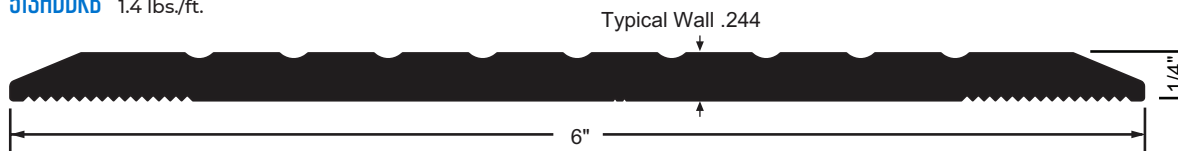

613HD 1.66 lbs./ft.
613HDDKB 1.66 lbs./ft.

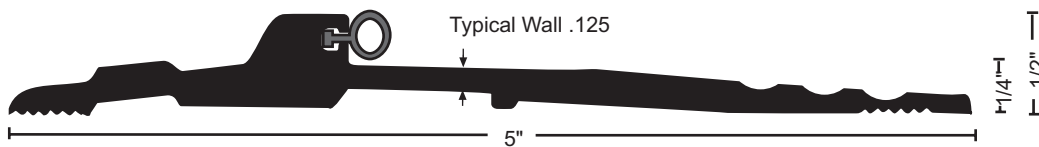

896HD 1.01 lbs./ft.
896HDDKB 1.01 lbs./ft.



BUMPER SEAL

- Seals against the door providing weather resistance
- Vinyl ("V") supplied unless other material specified

Options:
NGP-TPV ("N")
Silicone ("S")

TRANSITIONS / COMPONENTS

HALF SADDLE AND EXTENDED WIDTH

All products this page



EXTENDED WIDTH

- ▶ Create wider saddle or half saddle transitions
- ▶ Furnished with aluminum spline or thermal spline for field assembly
- ▶ Optional welded assemblies

EXAMPLES - HOW TO ORDER:

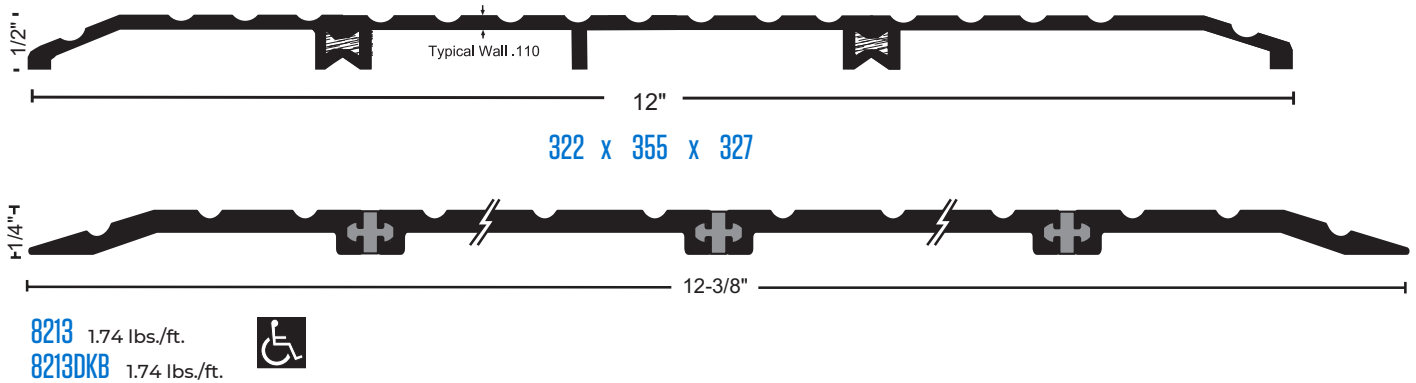

HALF SADDLE AND EXTENDED WIDTH COMPONENTS

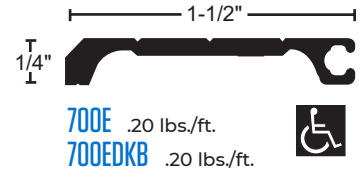
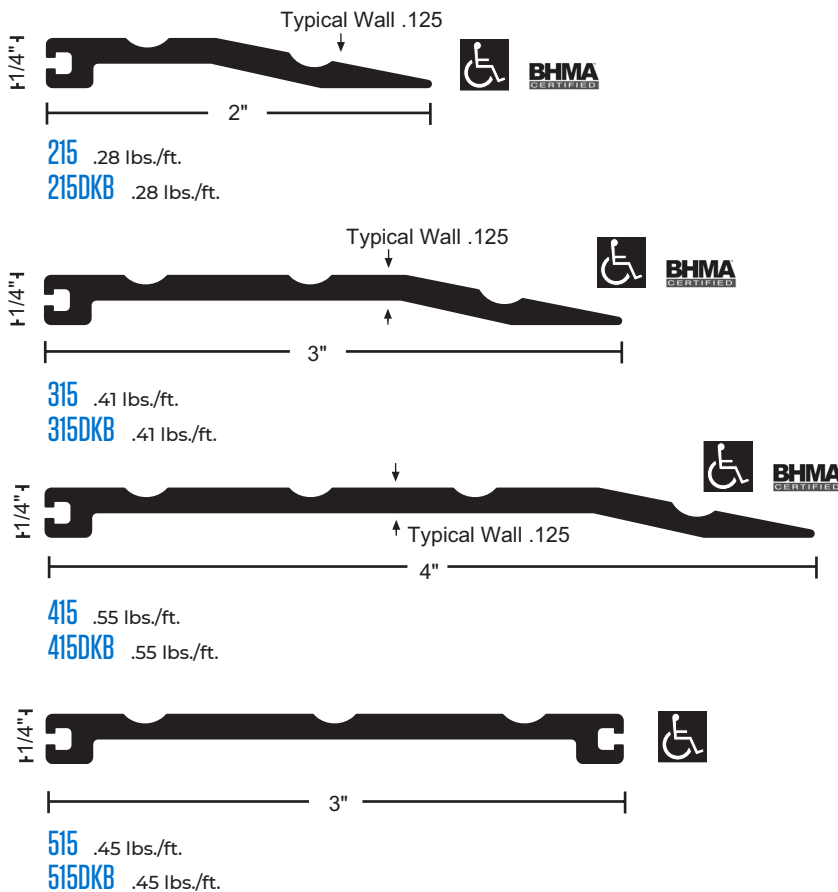

MATERIALS & FINISHES

- Aluminum Mill (Standard)
- DKB - Aluminum Dark Bronze

Optional:
Slip Resistant
SIA Finish

FASTENERS

- #10 x 1-1/2" FH zinc plated wood screws furnished.
- Dark bronze supplied with DKB transitions.

TRANSITIONS / COMPONENTS

HALF SADDLE AND EXTENDED WIDTH

All transitions this page

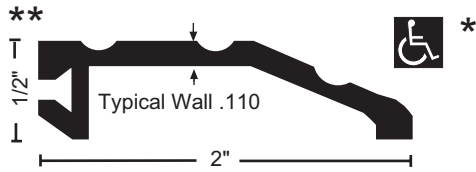

321 .34 lbs./ft. **BHMA**
321DKB .34 lbs./ft.

MATERIALS & FINISHES
 • Aluminum Mill (Standard)
 • DKB - Aluminum Dark Bronze

Optional:
 Slip Resistant
 SIA Finish

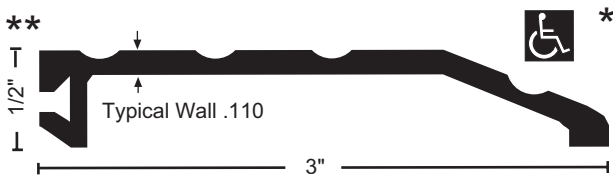

322 .48 lbs./ft. **BHMA**
322DKB .48 lbs./ft.

FASTENERS
 • #10 x 1-1/2" FH zinc plated wood screws furnished.
 • Dark bronze supplied with DKB transitions.

* When installed with the non-beveled edge FLUSH with flooring, or where no greater than 1/4" vertical rise occurs.

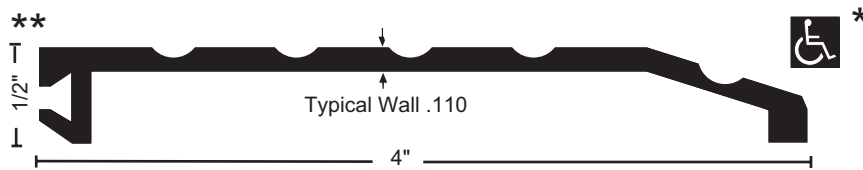

327 .60 lbs./ft.
327DKB .60 lbs./ft.

** Designed for thermal break. Bumper seal not available.

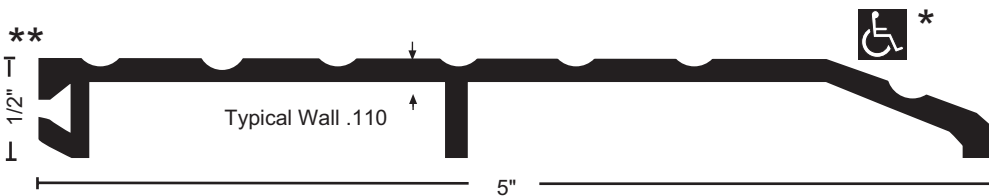

350 .83 lbs./ft. **BHMA**
350DKB .83 lbs./ft.



355 .79 lbs./ft. **BHMA**
355DKB .79 lbs./ft.

TRANSITIONS/COVER PLATES

HALF SADDLE, OFFSET TRANSITIONS, ALUMINUM COVER PLATES

HALF SADDLE

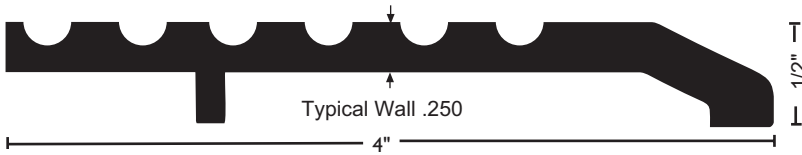

324 1.20 lbs./ft.
324DKB 1.20 lbs./ft.

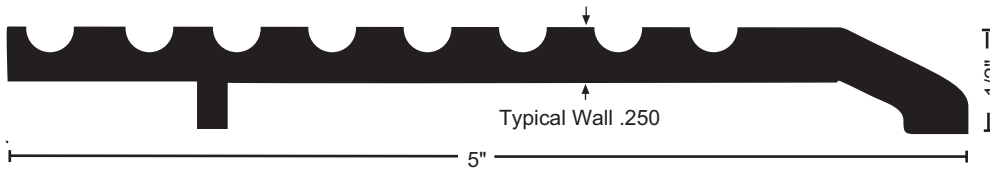

325 1.32 lbs./ft.
325DKB 1.32 lbs./ft.

All transitions this page



* when installed with the non-beveled edge flush with flooring, or where no greater than 1/4" vertical rise occurs.

OFFSET TRANSITIONS

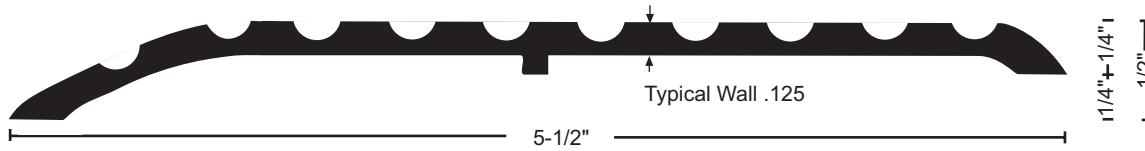

653 .78 lbs./ft.
653DKB .78 lbs./ft.

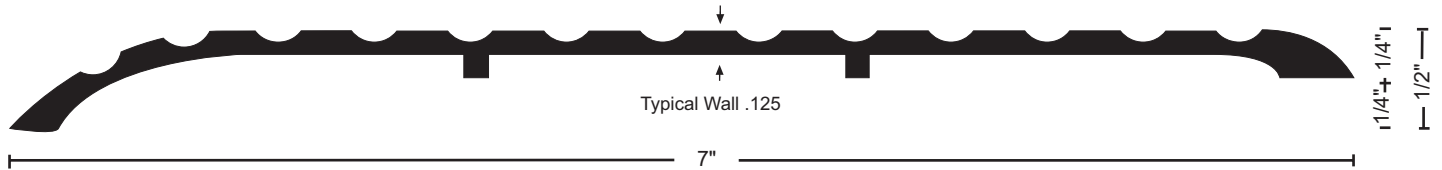

659 .89 lbs./ft.
659DKB .89 lbs./ft.

ALUMINUM COVER PLATES

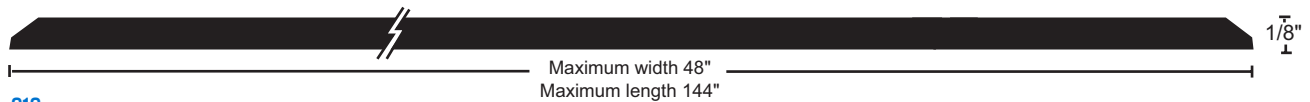

818 1/8"



814 1/4"

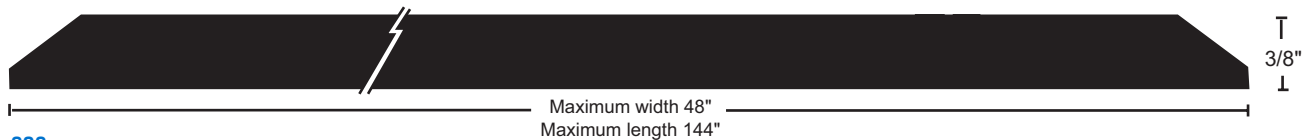

838 3/8"

TRANSITIONS/ENDS/ASSEMBLIES

CUSTOM TRANSITION OPTIONS

RETURN CLOSED ENDS

Return Closed Ends (RCE's) are available on most beveled transitions. The corner is miter cut on a 45 degree angle and returned to the face of the door frame for a neat, clean, finished appearance. Specify: "RCE"

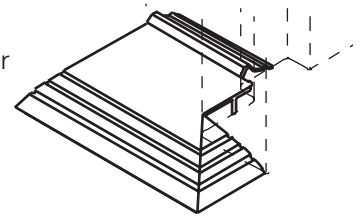

CUSTOM FABRICATED TRANSITIONS

Our Custom Fab dept. specializes in producing custom made-to order transitions to your specifications. Submit your details to our technical dept. for a quotation and drawing for your approval. Components are used to build special assemblies like the one illustrated below. Aluminum, Brass and Stainless Steel Cover Plates are also custom formed and welded to meet special requirements.

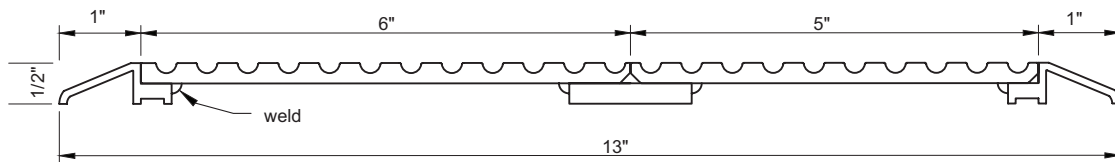

8137 x 8146 (Rip to 6") x 8145 x 8137 x Bar4 x Welded profile Assembly View

SPORTS FLOOR TRANSITION ASSEMBLIES

Wood gymnasium sports floors are designed to be free floating. We offer transition assemblies to cover the transition from the primary floor to the sports floor. As the sports floor shifts, the transition assembly will allow expansion and contraction by the top plate moving with the sports floor.

Material supplied loose. NO HOLES standard.

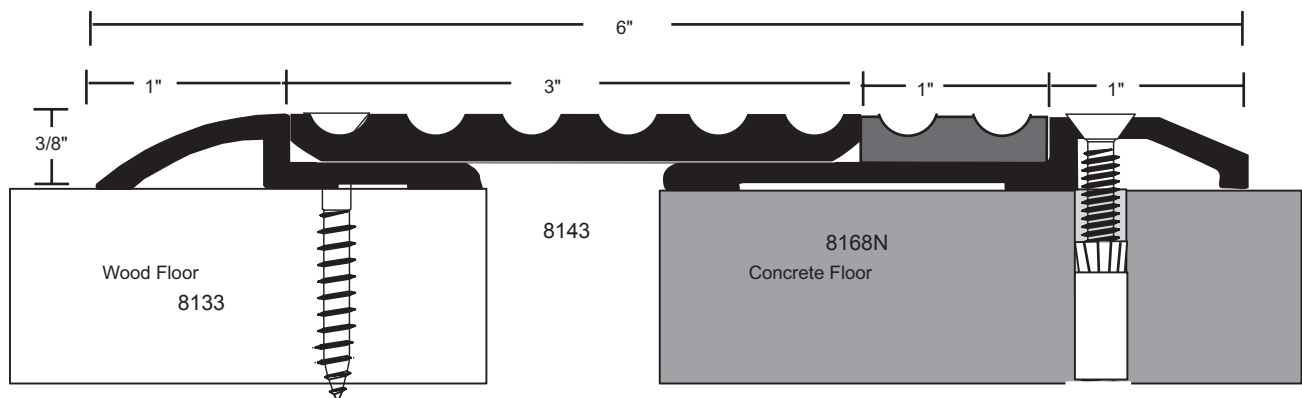

8133 x 8143 x 8168N (Neoprene) x 8139 x 10-24 MS/LA

Also available in 1/2" high and in other widths - contact NGP Technical Department

Available 1/2" high and in a variety of widths.

Contact the NGP Technical Department for additional information.

EDGE COMPONENTS

CUSTOM FABRICATED COMPONENTS

All transitions this page



Choose from various height and width components to build custom transitions to meet special job requirements. For assistance contact our tech support team.

Select the proper height edge components. Select the appropriate center plates to construct the width needed. Plates may be butted together or ripped to make specific widths. Support joints and wider spans with bar supports.

Transition assembly plates may be used fluted or smooth side up. Slip-resistant SIA finish can be applied to all parts.

Transition assembly components may be ordered separately for field assembly or welded into one piece units in our custom fabrication shop. They are supplied undrilled unless a template is provided. Ripping and beveling options are available. All custom fabricated assemblies have a tolerance of +/- 1/16".

If a welded assembly is desired, specify "welded".

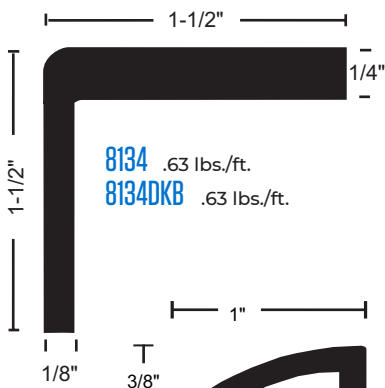

8134 .63 lbs./ft.
8134DKB .63 lbs./ft.

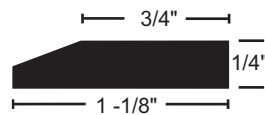

8136 .30 lbs./ft.
8136DKB .30 lbs./ft.



8138 .27 lbs./ft.



8133 .31 lbs./ft.
8133DKB .31 lbs./ft.

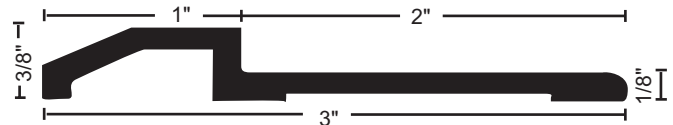

8139 .44 lbs./ft.
8139DKB .44 lbs./ft.

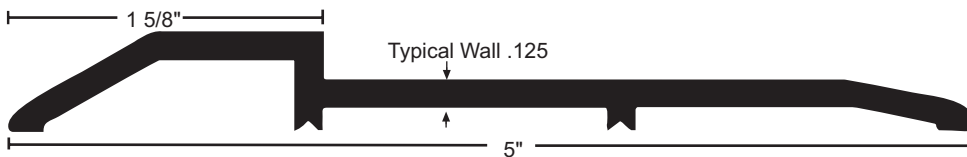

882 .83 lbs./ft.

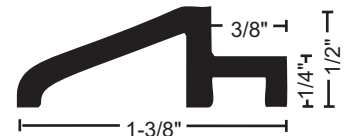

8137 .26 lbs./ft.
8137DKB .26 lbs./ft.

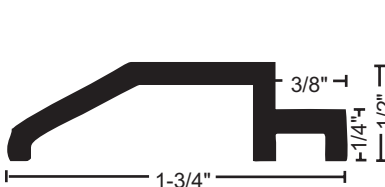

8140 .28 lbs./ft.
8140DKB .28 lbs./ft.



8141 .34 lbs./ft.
8141DKB .34 lbs./ft.

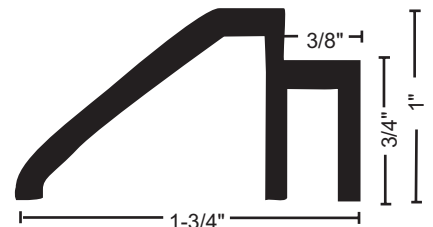

8152 .44 lbs./ft.
8152DKB .44 lbs./ft.

TRANSITION ASSEMBLIES

CUSTOM FABRICATED COMPONENTS



8142 .50 lbs./ft. **8142DKB** .50 lbs./ft.



8168N Neoprene .11 lbs./ft. self adhesive, used as an expansion joint or thermal break between floor plates.

All transitions this page



BHMA CERTIFIED except 8168N

except 8163, 8164, 8167

Optional: Slip Resistant SIA Finish

MATERIALS & FINISHES

- Aluminum Mill (Standard)
- DKB - Aluminum Dark Bronze

FASTENERS

- #10 x 1-1/2" FH zinc plated wood screws furnished.
- Dark bronze supplied with DKB transitions.



8143 .75 lbs./ft. **8143DKB** .75 lbs./ft.



8144 1.00 lbs./ft. **8144DKB** 1.00 lbs./ft.



8145 1.20 lbs./ft. **8145DKB** 1.20 lbs./ft.



8146 1.50 lbs./ft. **8146DKB** 1.50 lbs./ft.



8147 1.70 lbs./ft. **8147DKB** 1.70 lbs./ft.



8148 2.00 lbs./ft. **8148DKB** 2.00 lbs./ft.



8149 2.20 lbs./ft. **8149DKB** 2.20 lbs./ft.



8150 2.40 lbs./ft. **8150DKB** 2.40 lbs./ft.



8163 .75 lbs./ft. **8163DKB** .75 lbs./ft.



8164 1.00 lbs./ft. **8164DKB** 1.00 lbs./ft.



8167 1.76 lbs./ft. **8167DKB** 1.76 lbs./ft.

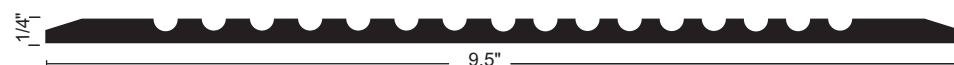

8170 2.33 lbs./ft. **8170DKB** 2.33 lbs./ft.

BAR SUPPORTS

Used as support under transition assemblies

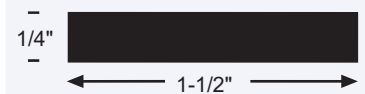
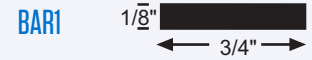

BAR4

illustrations shown at 50%

SADDLE TRANSITIONS

STAINLESS AND ARCHITECTURAL BRONZE TRANSITIONS

All transitions this page



STAINLESS STEEL 1/4"

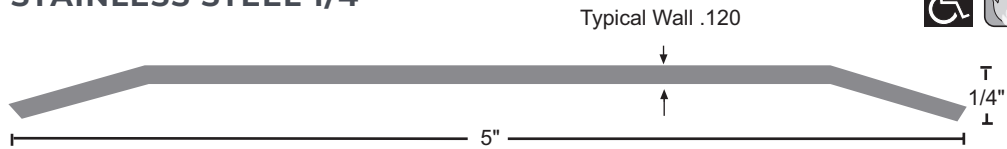

513SS 2.07 lbs./ft.

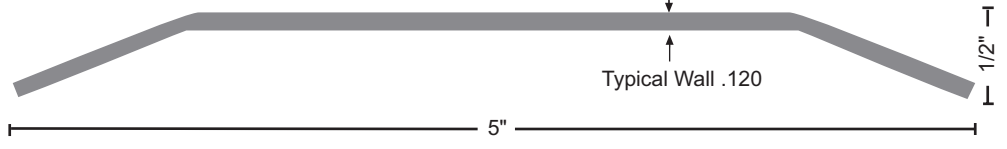

512SS 2.07 lbs./ft.

ARCHITECTURAL BRONZE 1/4"

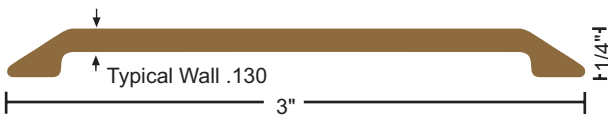

411BR 1.42 lbs./ft.

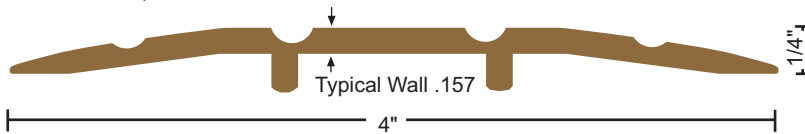

413BR 1.52 lbs./ft.

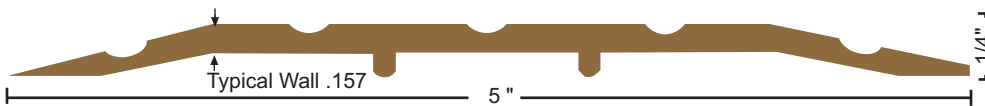

513BR 1.96 lbs./ft.

FASTENERS

- #10 X 1-1/2" solid brass wood screws furnished.
- Antique bronze finish screws provided with dark bronze transitions.

NOTE: Transitions supplied with holes down the center. Specify NO HOLES for blank material.

ARCHITECTURAL BRONZE 1/2"

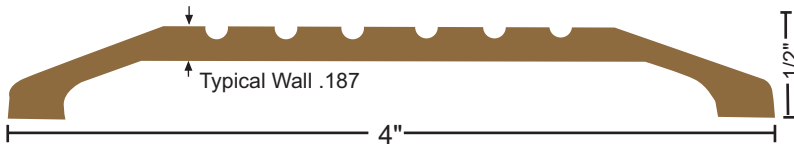

424BR 2.28 lbs./ft. **BHMA** CERTIFIED

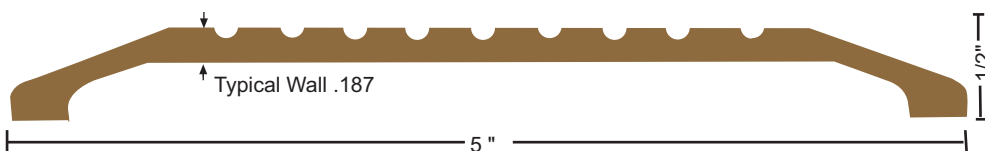

425BR 2.84 lbs./ft. **BHMA** CERTIFIED

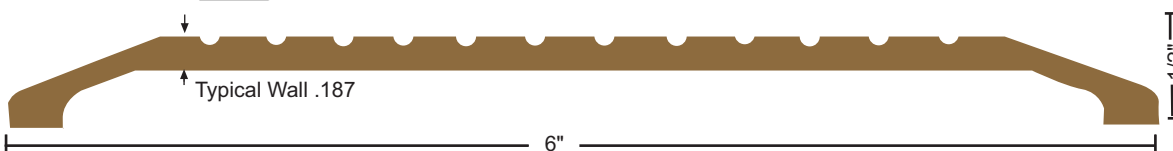

426BR 3.33 lbs./ft. **BHMA** CERTIFIED

CUSTOM TRANSITIONS

ARCHITECTURAL BRONZE COMPONENTS

All transitions this page



Choose from various height and width components to build custom transitions to meet special job requirements. See the custom fabricated transition example illustrated on page T9. For assistance contact our tech support team.

Select the proper height edge components. Select the appropriate center plates to construct the width needed. Plates may be butted together or ripped to make specific widths. Support joints and wider spans with bar supports.

Transition assembly plates may be used fluted or smooth side up. Slip-resistant SIA finish can be applied to all parts.

Transition assembly components may be ordered separately for field assembly or welded into one piece units in our custom fabrication shop. They are supplied undrilled unless a template is provided. Ripping and beveling options are available. All custom fabricated assemblies have a tolerance of +/- 1/16".

If a welded assembly is desired, specify "welded".

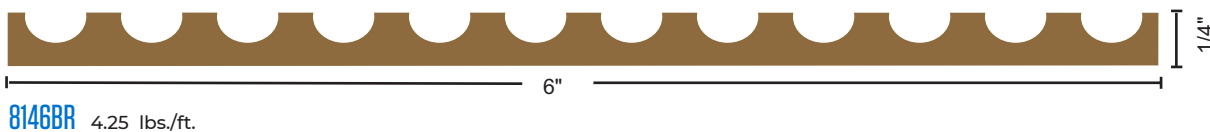
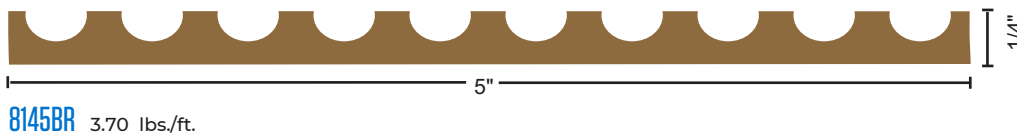
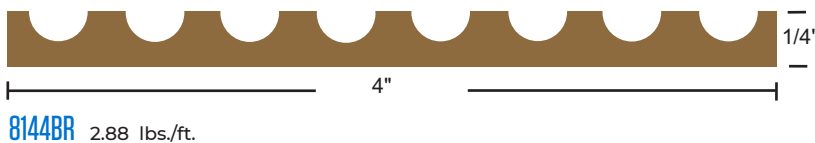
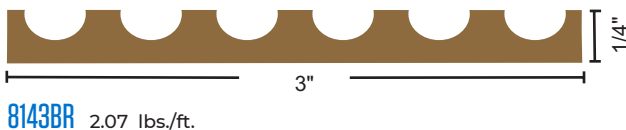
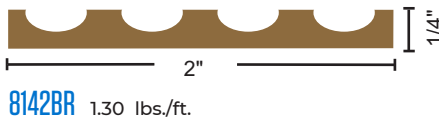
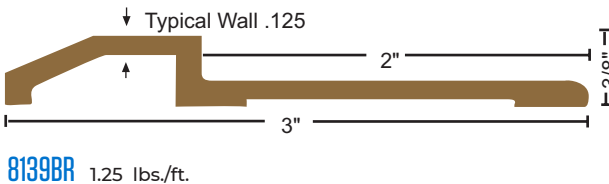
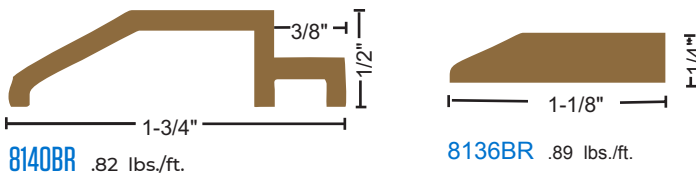

BAR SUPPORTS

Used as support under transition assemblies

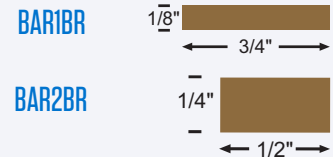

INTERLOCKING REDUCERS

CUSTOM FABRICATED COMPONENTS

ADA COMPLIANT

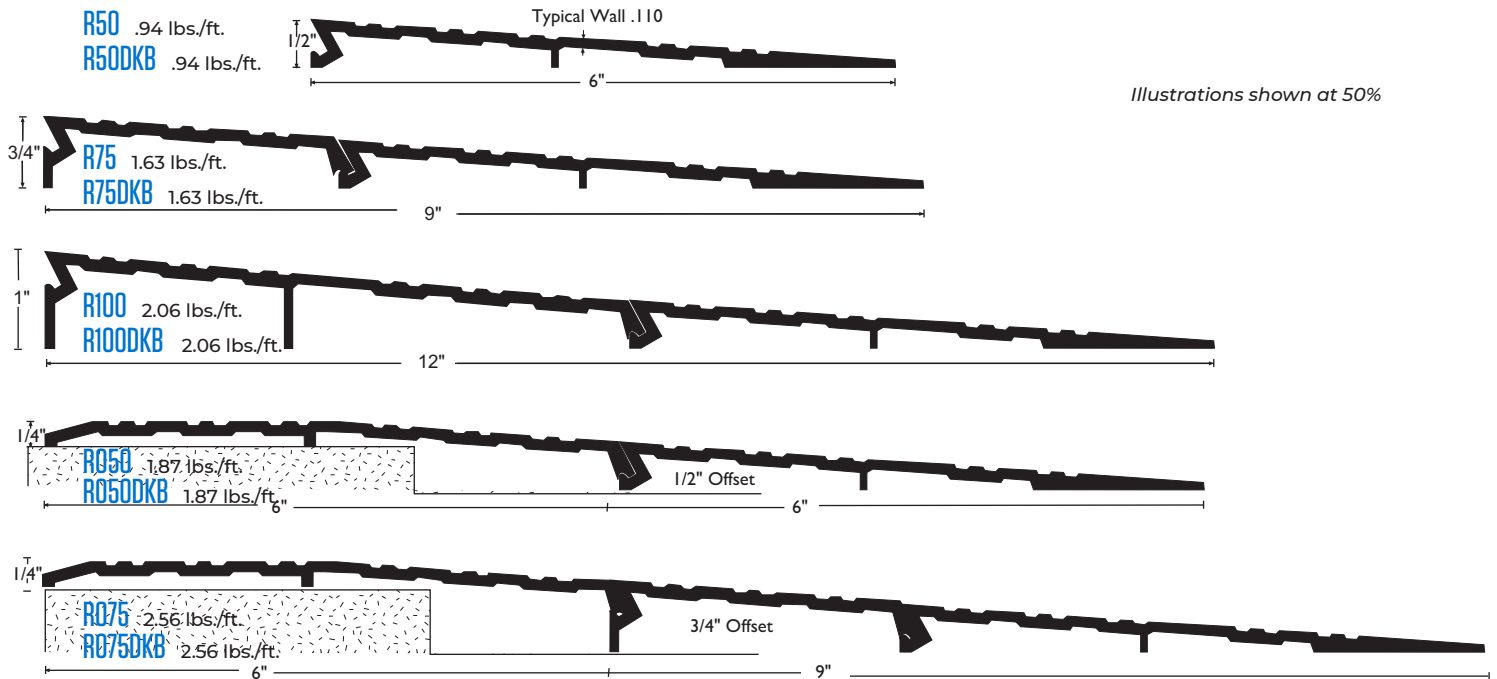

Illustrations shown at 50%

RETURN CLOSED ENDS FOR REDUCERS

- Return closed ends provide an attractive finished appearance to reducers.
- They are available in several lengths and can be trimmed to accommodate any size reducer assembly.
- RCE's are also available with slip-resistant "SIA" finish (suffix "SIA").



INTERLOCKING RUBBER REDUCERS

- Supplied with beveled ends - (end slope = 1:2). Specify if straight cut is required.
- Rubber reducer sections may be combined with aluminum reducer components for higher rises, or with 6" flat aluminum interlocking transition #957 for offset conditions.
- Black silicone adhesive available to secure reducers without fasteners. Specify RR5007BL, each tube will secure 2 reducers 12" wide x 36" long (6 square feet.)

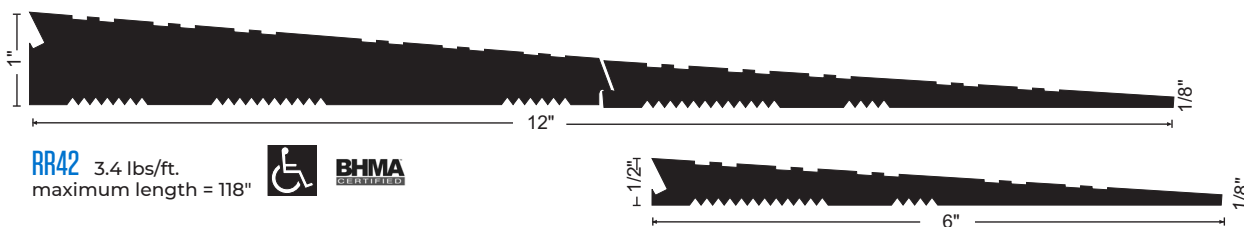

Slope = 1:12
Illustrations shown at 50%

TRANSITION FASTENERS

STANDARD AND OPTIONAL FASTENERS

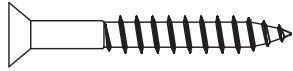

#10 x 1 1/2" Phillips Flat Head Wood Screw
Use 1/8" Drill bit



Phillips Head
Top View



Spanner Head
Top View



Torx Security
Top View

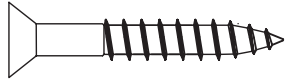

#12 x 1 1/2" Phillips Flat Head Wood Screw
Use 9/64" Drill bit
Also #12 x 1"

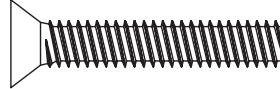

#1/4-20 x 1 1/2" Phillips Flat Head
Machine Screw

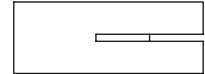

#1/4-20 Expansion Anchor
Carbon Steel
Use 3/8" Drill bit

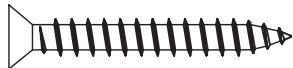

#10 x 1 1/2" Phillips Flat Head Stainless Steel
Sheet Metal Screw
Use 1/8" Drill bit
Also #10 x 1", #10 x 2", #10 x 2 1/2", #10 x 3"

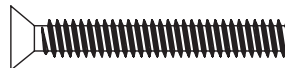

#10-24 x 1 1/2" Phillips Flat Head
Machine Screw
Also #10-24 x 3/4", #10-24 x 1"



#10-24 Lead Anchor
Use 3/8" Drill bit and
Powers seating tool

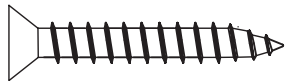

#12 x 1 1/2" Phillips Flat Head
Sheet Metal Screw
Use 9/64" Drill bit
Also: #12 x 1"

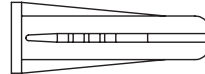

Plastic Anchor Various Sizes
Use Drill Size = Anchor Size

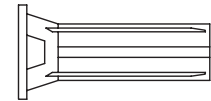

Lead Expansion Shield
4% Antimonial Lead
Use 5/16" Drill bit



#6 x 3/4" Phillips Flat Head Self-tapping
Machine Screw
Use 3/32" Drill bit

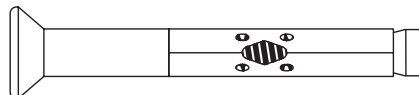

#1/4-20 Phillips Combo Flat Head Machine
Screw/Anchor
Use 1/4" Drill bit

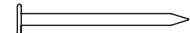

#18 x 7/8" Nail for use with 80B
Hook Strip

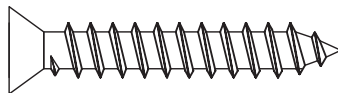

Hilti Kwik-Con II 1/4" x 1-3/4" Screw,
Available with Phillips Head or Torx Head.
Use Hilti TKC large concrete bit SDS 1/4"
Tough Carbide



NATIONAL GUARD PRODUCTS, INC.

4985 East Raines Road | Memphis, TN 38118
Phone: 800-647-7874 | Fax: 800-255-7874
orders@ngp.com | quotes@ngp.com

ngp.com