



# SEALS

EDGES, ASTRAGALS  
& SPECIALTY PRODUCTS





## EDGES, ASTRAGALS & SPECIALTY PRODUCTS INDEX:

Door Aligning Astragals.....	EA9
Door Edges.....	EA9
Door Edges with Astragals, Active.....	EA10
Door Edges with Astragals, Inactive.....	EA11
Double Egress Door Edges & Astragals.....	EA8
Finger Guard.....	EA3
Flood Shield.....	EA5-EA6
Hinge Side Finger Guard.....	EA4
Metal Edges & Astragals Order Form.....	EA12
Powder Coat Chart.....	EA2
Security Door Guard.....	EA7-EA8
Technical Information: Ratings and Finishes.....	EA1
"Z" Astragals.....	EA9

## NUMERICAL INDEX:

FS10.....	EA5-EA6	SDG-10B.....	EA7	555.....	EA9
FS22.....	EA5-EA6	SDG-26D.....	EA7	560.....	EA11
FS34.....	EA5-EA6	540.....	EA9	561.....	EA11
SDG-BRKT-MW.....	EA8	541.....	EA9	562.....	EA11
SDG-BRKT-WB.....	EA8	542.....	EA9	563.....	EA11
SDG-DS.....	EA7	543.....	EA9	570.....	EA9
SDG-ET.....	EA7	545.....	EA9	572.....	EA9
SDG-HO.....	EA7	550.....	EA10	574.....	EA9
SDG-WS.....	EA7	551.....	EA10	2248.....	EA3
SDG-3.....	EA7	552.....	EA10	2252.....	EA4
SDG-4.....	EA7	553.....	EA10		

# TECHNICAL INFORMATION

## RATING SYMBOLS LEGEND



**POSITIVE PRESSURE - CERTIFIED by UL to ANSI/UL10C.** Complies with IBC, NFPA 80 and NFPA 252 for application to Hollow Metal fire doors rated up to 3 Hrs., and Wood fire doors rated up to 90 minutes.



**CERTIFIED by UL to CAN/ULC-S104 and ANSI/UL10B.** Complies with NFPA 80 and NFPA 252 for application to Hollow Metal fire doors rated up to 3 Hrs., and Wood fire doors rated up to 90 minutes.

**Corrosion Resistant Sealer:** A polymeric green seal (non-chrome) corrosion resistance extender is applied under all NGP powder coat finishes. Laboratory salt spray tests prove a dramatic increase in corrosion resistance on steel products with this sealer applied to the metal prior to the powder coat finish.

**Salt Spray Test Results:** Steel door edges and astragals with NGP's corrosion resistant sealer and powder coat finish withstood 1,248 hours without failing. This is 2 ½ times longer than the protection provided by powder coating only.

# POWDER COAT CHART

## STANDARD & OPTIONAL COLORS

---

Colors may have a slight variation on your monitor or printer.  
Contact NGP for actual color samples to be mailed.

### STANDARD COLORS



GPZ-Gray Primer

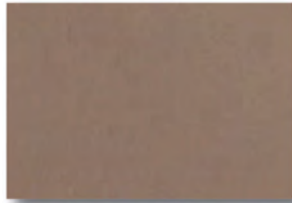

T-Tan



BPR-Beige Primer  
(matches Steelcraft)



DKB-Dark Bronze

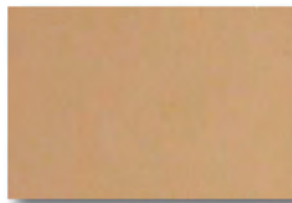

PTY-Putty  
(matches Anemostat Beige)



CAB-California Bronze  
(matches Anemostat)

### OPTIONAL COLORS

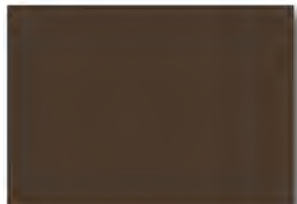

WB-Walnut Brown  
(matches Timely Browntone)



ASL-Aluminum Silver  
(metallic)



TBL-Textured Black  
GBL-Gloss Black  
MBL-Matte Black



MW-Magnolia White  
(matches Timely Western White)

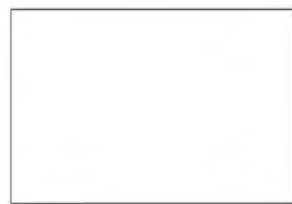

W-White

### POWDER COAT FINISH

The standard finish for each product is indicated on the catalog page and in the price list and will be provided unless an optional finish is indicated. The following color options can be provided on any Door Edge & Astragal:

Custom colors and color matching available – Consult customer service for details

# FINGER GUARD

\*Up To 3 Hours  
Metal Doors,  
1-Hour Wood Doors



Finger Guard is Designed to Help Prevent Injury to Fingers Accidentally Placed in the Hinge Area of a Door. This Unique Product Features an Internal Spring Mechanism That Maintains Constant Tension Against the Polyethylene Fabric Which Helps Prevent Fingers From Entering the Dangerous Area Behind the Edge of the Door.

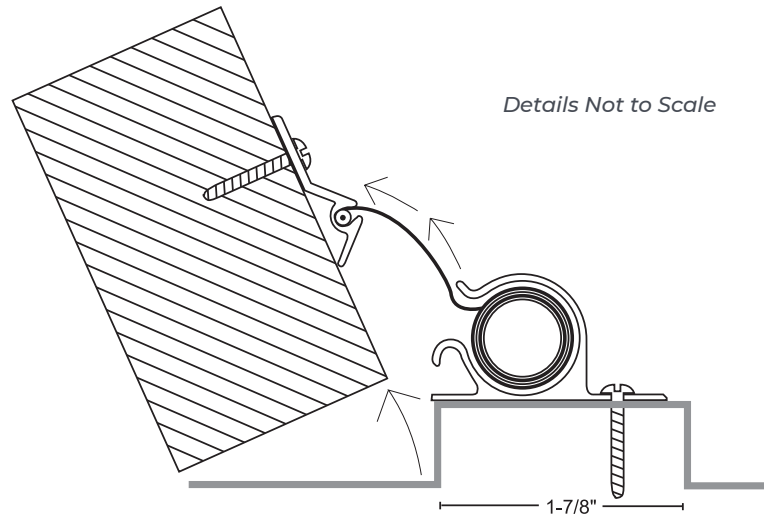

- ▶ Ideal for Senior & Childcare Facilities
- ▶ Anodized Aluminum Housing
- ▶ Durable "Endless Cycle" Spring Mechanism
- ▶ Fire-Resistant Woven Polyethylene Fabric
- ▶ Rated Up To 3 Hours Metal Doors, 1-Hour Wood Doors
- ▶ 82" for 7' Door Opening
- ▶ 38" Dutch Door Size
- ▶ Custom Lengths 12" up to 86" Available. Order 2" Less Than Opening Height to Allow for the Stop on the Door Frame Head and Door Bottom Undercut
- ▶ Not Field Sizable
- ▶ Mounts on Push Side of Door
- ▶ Suitable for Doors Swinging Up To 180 Degrees
- ▶ #6 x 1/2" Tek Self-Drilling Screws Furnished

Door Shown in Open Position



SKU	DESCRIPTION
<b>2248A</b>	Aluminum Clear Anodized with White Polyethylene
<b>2248B</b>	Black Anodized with Black Polyethylene
<b>2248DKB</b>	Dark Bronze Anodized with Black Polyethylene

Available in 38", 76", 82" and 86" Standard Lengths

# HINGE SIDE FINGER GUARD



- ▶ Flexible Vinyl With Rigid Thermoplastic Base
- ▶ Rated Up To 3 Hours Metal Doors, 1½" Hours Wood Doors
- ▶ Available in Brown, Charcoal and White
- ▶ 83" Length
- ▶ Can Be Cut in the Field
- ▶ Mounts on Pull Side of Door
- ▶ #6 X ½" Tek Self-Drilling Screws

SKU	COLOR
<b>2252C</b>	Charcoal
<b>2252W</b>	White

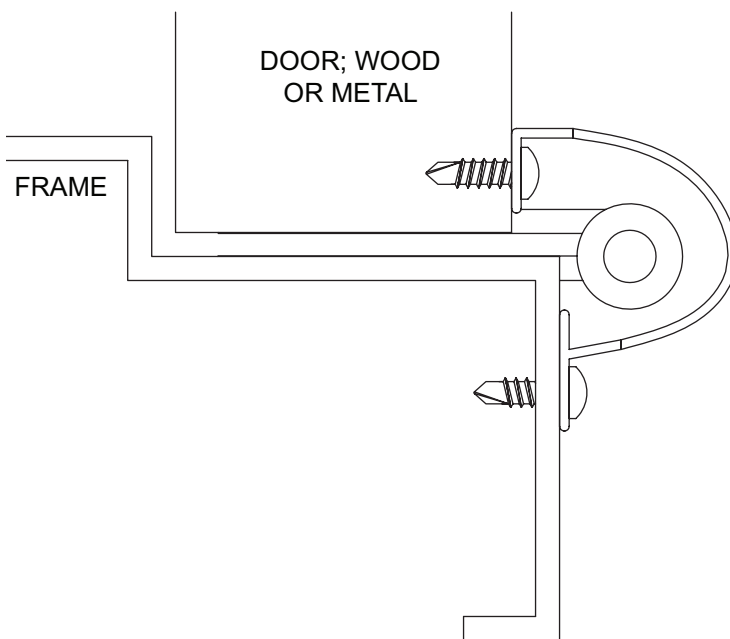

# FLOOD SHIELD

## DROP IN AND GO!

Flood Shield is Designed to Help Protect Door Openings and Building Contents from Flood Water. This Unique Product Features a Spring Mechanism that Maintains Constant Tension Against the Gasketing to Create a Solid Flood Barrier.

- ▶ Stainless Steel Springs Provide Constant Seal Compression
- ▶ ¼" Marine Grade Aluminum Shield with Handle Cutouts
- ▶ Closed Cell Neoprene Rubber Gaskets Installed on Bottom and Sides of Shield

SKU	HEIGHT	
<b>FS10</b>	12" High	With 10" of Flood Protection
<b>FS22</b>	24" High	With 22" of Flood Protection
<b>FS34</b>	36" High	With 34" of Flood Protection

\* Up To 96" Wide

\* Over 50" Support Post Recommended

\* Complies With Guidelines of the Federal Emergency Management Agency (FEMA) and Federal Insurance and Mitigation Administration (FIMA) for Use on Doors in Flood Prone Areas.



Universal Anodized Aluminum Channels can be Mounted to Inside or Outside of Frame



MADE IN USA

# FLOOD SHIELD

- ▶ ¼" Marine Grade Aluminum Shield with Handle Cutouts
- ▶ Closed Cell Neoprene Rubber Gaskets Installed on Bottom and Sides of Shield
- ▶ Anodized Aluminum Mounting Channels
- ▶ Universal Channels can Install Inside or Outside Mount
- ▶ Dark Bronze/Black Anodized Mounting Channels Available (Specify)
- ▶ Stainless Steel Springs Provide Seal Compression
- ▶ #10 x 1 ½" Stainless Steel Sheet Metal Screws
- ▶ Complies with Guidelines of the Federal Emergency Management Agency (FEMA) and Federal Insurance and Mitigation Administration (FIMA) for Use on Doors in Flood Prone Areas
- ▶ Lengths Up To 96" Available
- ▶ A Center Support Post is Recommended for Installations Over 50"
- ▶ A Threshold is Recommended if Sill is Not Smooth and Clean
- ▶ Orders for this Product are Non-Changeable and Non-Cancellable

SKU	HEIGHT	
<b>FS10</b>	12" High	With 10" of Flood Protection
<b>FS22</b>	24" High	With 22" of Flood Protection
<b>FS34</b>	36" High	With 34" of Flood Protection

## MOUNTING CHANNEL

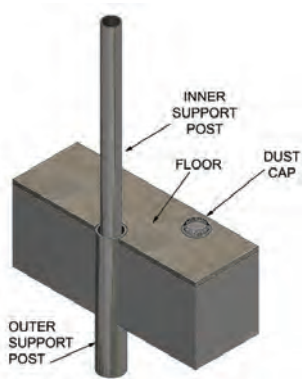
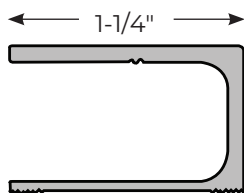

**FSSP** *Optional Center Support & Cap*

## INSIDE MOUNT

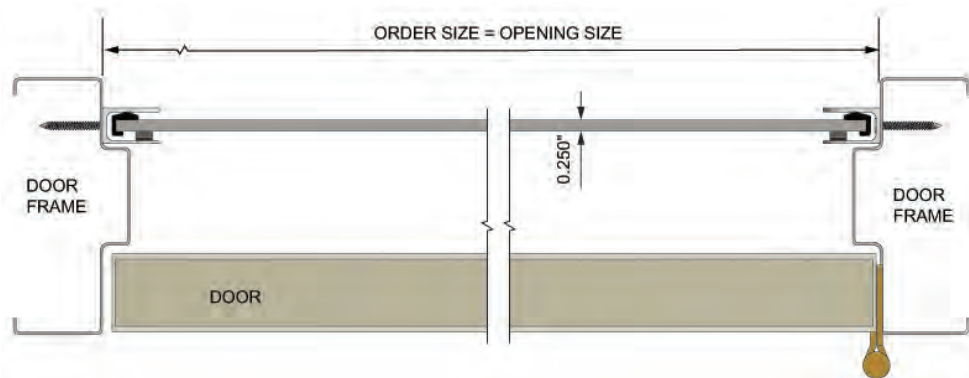

## OUTSIDE MOUNT

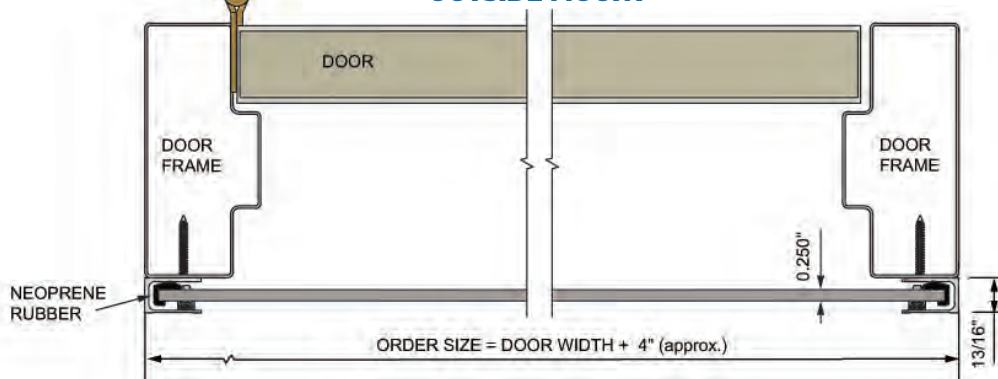

# SECURITY DOOR GUARD



## SDG

- ▶ Prevents Door From Opening, Allowing Guest or Resident Privacy When Engaged
- ▶ Disengage to Operate Door Normally
- ▶ Can Not be Used to Prop Door Open
- ▶ Silicone Pad at Door Contact Point
- ▶ UL Listed Fire Door Accessory
- ▶ Mount 48" or Less Above Floor for ADA Compliance

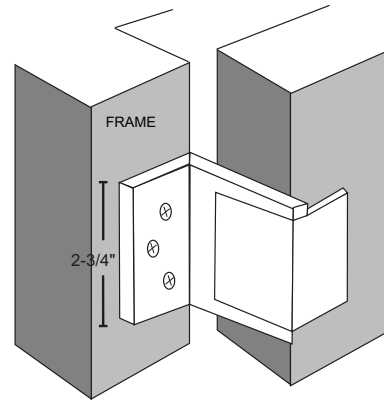
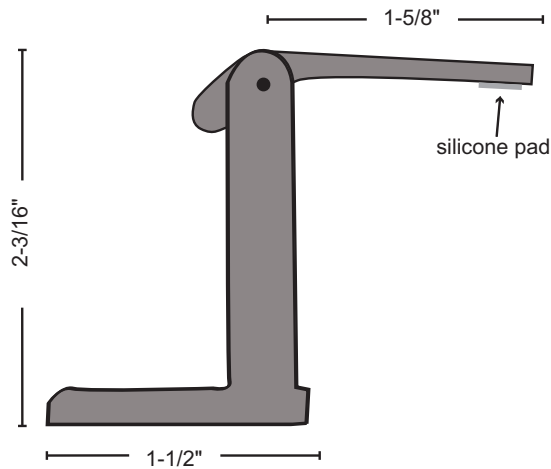

SKU	COLOR
<b>SDG-3</b>	Polished Brass US3
<b>SDG-4</b>	Satin Brass US4
<b>SDG-10B</b>	Dark Bronze US10B
<b>SDG-26D</b>	Satin Chrome US26D

## HOLD-OPEN ACCESSORY

### SDG-HO



- ▶ Foam Rubber Block With Slot
- ▶ Slides Onto Security Door Guard Allowing the Door to Be Held Open by Housekeeping or Service Personnel
- ▶ Will Not Mark or Mar Door or Security Door Guard

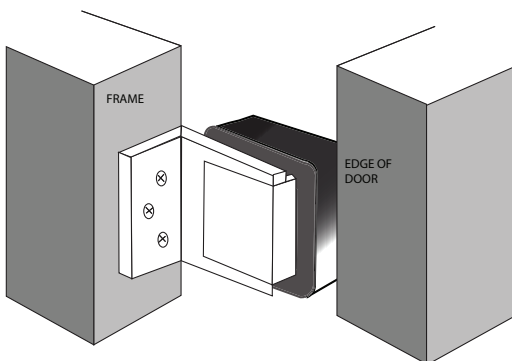

## STICKERS FOR RETROFIT

- ▶ Covers Holes Left in Door and Frame From Removal of Swing-Bar Type Door Guards



### SDG-DS SDG-WS

## SDG-ET Emergency Tool (not illustrated)

- ▶ Used to Deactivate Security Door Guard for Emergency Access

# SECURITY DOOR GUARD BRACKET

## SDG-BRKT

- Designed for Timely or Redi-Frame Pre-Finished Steel Doorframes With Snap on Trim
- Bracket Allows SDG to be Installed in the Correct Position for Proper Operation

SKU	COLOR
<b>SDG-BRKT-MW</b>	Magnolia White
<b>SDG-BRKT-WB</b>	Walnut Brown

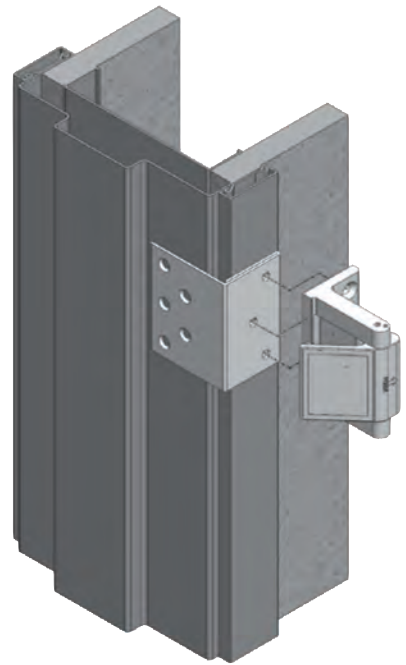
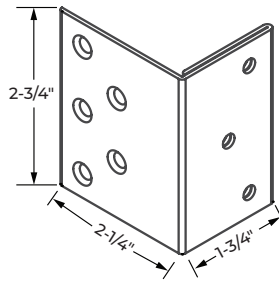

# DOOR EDGES AND ASTRAGALS



NGP Order Form (Page EA10) Indicating Model Number, Hand, Net Length, Hardware Preps, and Precise Hardware Locations Must Accompany All Orders.

- 20 Ga. Cold Rolled Steel on Edges and "Z" Astragals
- 18 Ga. Cold Rolled Steel on Astragal Welded to Edges
- For 1 3/4" Thick Doors (Inside Dim. 1 3/4" Actual)
- #8 x 3/4" Flat Undercut Phillips Head SMS
- Standard Finish = Tan (T) Powder Coat

## Available Options:

- Powder Coat Color Options - See Page EA2
- Stainless Steel 20 Ga., Type 304, #4 Brushed Finish - Suffix SS"
- Galvanneal
- Torx Security Screws
- Special Door Thickness: Available from 1 3/8" to 2 1/4"
- Lead Lining 1/16" Thick Available on Astragal Models Only. Not Available on "Z" Astragals

## "Z" ASTRAGALS

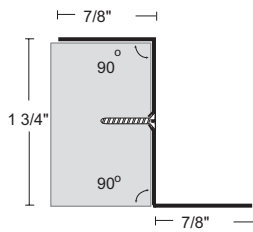

**570** SQUARE EDGE

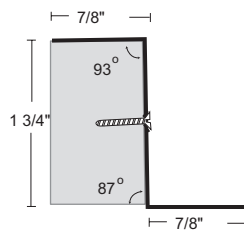

**572** BEVELED EDGE ON ACTIVE LEAF

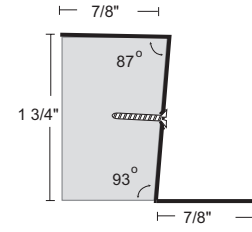

**574** BEVELED EDGE ON INACTIVE LEAF

## DOOR EDGES

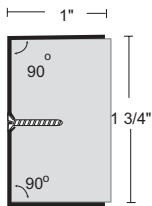

**540** SINGLE SQUARE EDGE

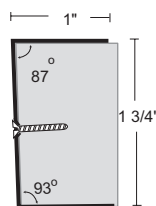

**542** SINGLE BEVELED EDGE

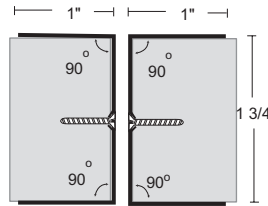

**541** SQUARE EDGE SET

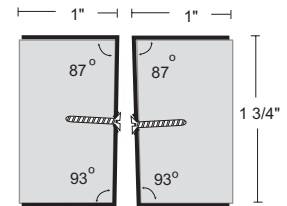

**543** BEVELED EDGE SET

## DOUBLE EGRESS

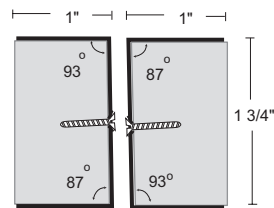

**545** PARALLEL BEVEL EDGE SET FOR DOUBLE EGRESS DOORS

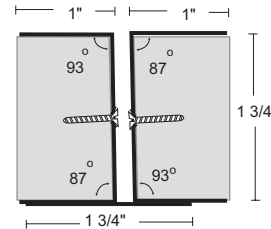

**555** PARALLEL BEVEL ASTRAGAL SET FOR DOUBLE EGRESS DOORS

# DOOR EDGES AND ASTRAGALS



NGP Order Form (Page EA10) Indicating Model Number, Hand, Net Length, Hardware Preps, and Precise Hardware Locations Must Accompany All Orders.

- ▶ 20 Ga. Cold Rolled Steel on Edges
- ▶ 18 Ga. Cold Rolled Steel on Astragal Welded to Edges
- ▶ For 1 3/4" Thick Doors (Inside Dim. 1 3/4" Actual)
- ▶ #8 x 3/4" Flat Undercut Phillips Head SMS
- ▶ Standard Finish = Tan (T) Powder Coat

### Available Options:

- ▶ Powder Coat Color Options - See Page EA2
- ▶ Stainless Steel 20 Ga., Type 304, #4 Brushed Finish - Suffix SS"
- ▶ Galvanneal
- ▶ Torx Security Screws
- ▶ Special Door Thickness: Available from 1 3/8" to 2 1/4"
- ▶ Lead Lining 1/16" Thick

## ASTRAGAL ON ACTIVE LEAF

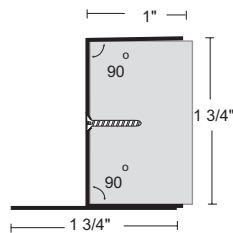

**550** SINGLE ASTRAGAL SQUARE EDGE

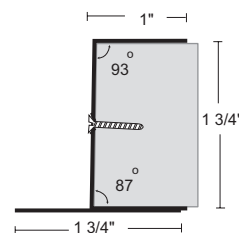

**552** SINGLE ASTRAGAL BEVELED EDGE

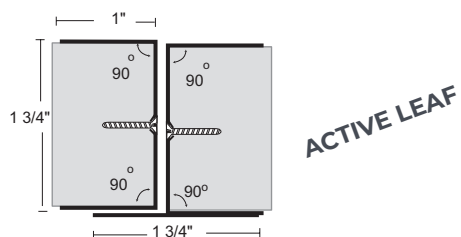

**551** ASTRAGAL SET SQUARE EDGE

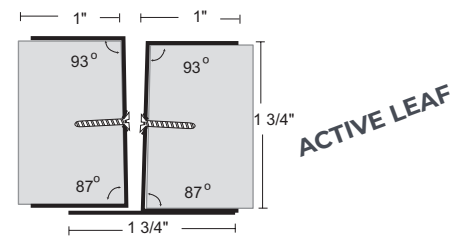

**553** ASTRAGAL SET BEVELED EDGE

Astragals Mounted on Active Leaf that are Prepped for a Lockset Will Be Notched for the Strike Lip, Unless Specified Otherwise.

# DOOR EDGES AND ASTRAGALS



NGP Order Form (Page EA10) Indicating Model Number, Hand, Net Length, Hardware Preps, and Precise Hardware Locations Must Accompany All Orders.

- ▶ 20 Ga. Cold Rolled Steel on Edges
- ▶ 18 Ga. Cold Rolled Steel on Astragal Welded to Edges
- ▶ For 1 3/4" Thick Doors (Inside Dim. 1 3/4" Actual)
- ▶ #8 x 3/4" Flat Undercut Phillips Head SMS
- ▶ Standard Finish = Tan (T) Powder Coat

## Available Options:

- ▶ Powder Coat Color Options - See Page EA2
- ▶ Stainless Steel 20 Ga., Type 304, #4 Brushed Finish - Suffix SS"
- ▶ Galvanneal
- ▶ Torx Security Screws
- ▶ Special Door Thickness: Available from 1 3/8" to 2 1/4"
- ▶ Lead Lining 1/16" Thick

## ASTRAGAL ON INACTIVE LEAF

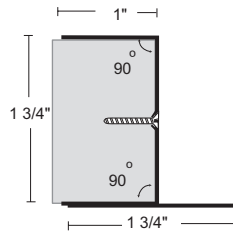

**560** SINGLE ASTRAGAL SQUARE EDGE

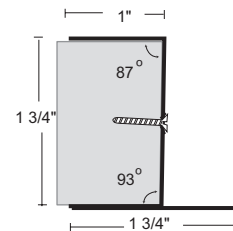

**562** SINGLE ASTRAGAL BEVELED EDGE

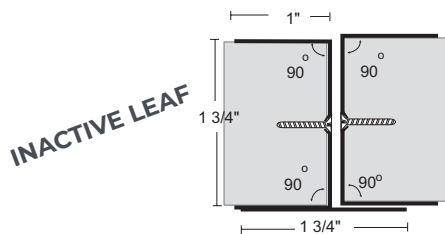

**561** ASTRAGAL SET SQUARE EDGE

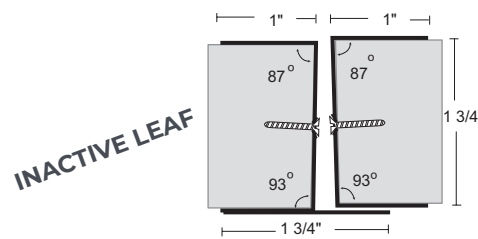

**563** ASTRAGAL SET BEVELED EDGE

Astragals Mounted on Active Leaf that are Prepped for a Lockset Will Be Notched for the Strike Lip, Unless Specified Otherwise.

# METAL EDGES & ASTRAGALS

## ORDER FORM

### STEP 1

### ORDER FORM FOR METAL EDGES/ASTRAGALS

ASTRAGAL ON ACTIVE DOOR		ASTRAGAL ON INACTIVE DOOR	
MODEL #		MODEL #	
551	(OUTSWING)	561	(INSWING)
553	RHR ACTIVE	563	RH ACTIVE
550	LHR INACTIVE	560	LH ACTIVE
552	RHR INACTIVE	562	RH INACTIVE
572		574	
OTHER MODEL #		OTHER MODEL #	
	(INSWING)		(OUTSWING)
	LH ACTIVE		RHR ACTIVE
	RH INACTIVE		LHR INACTIVE

### STEP 2

#### ACTIVE

#### INACTIVE

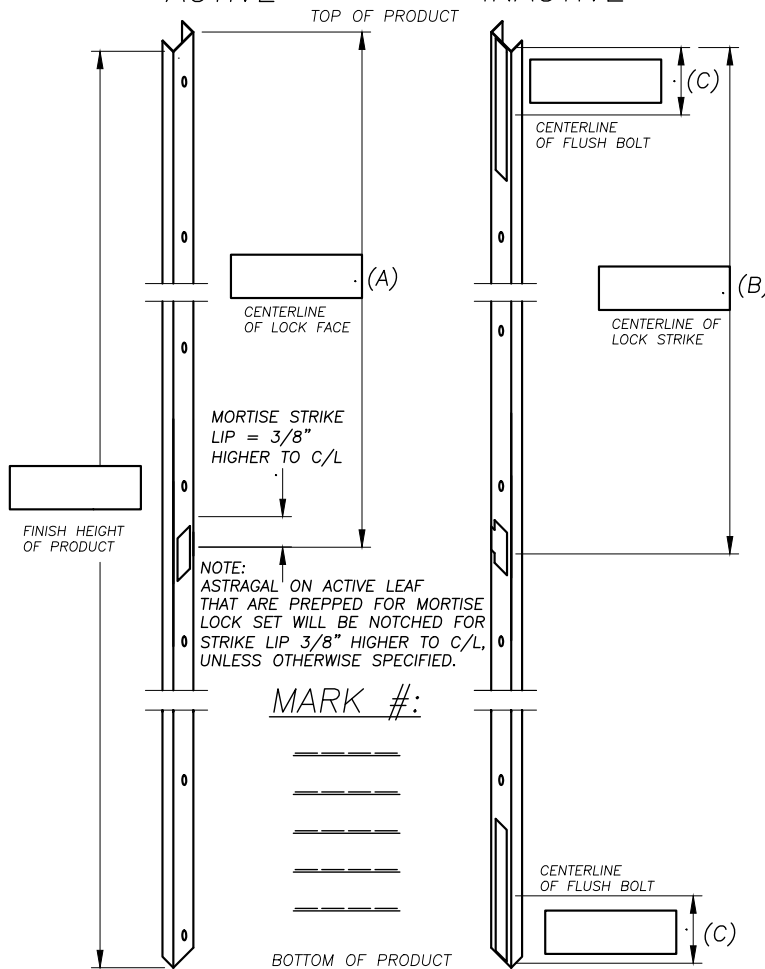

### STEP 3

#### PREPS

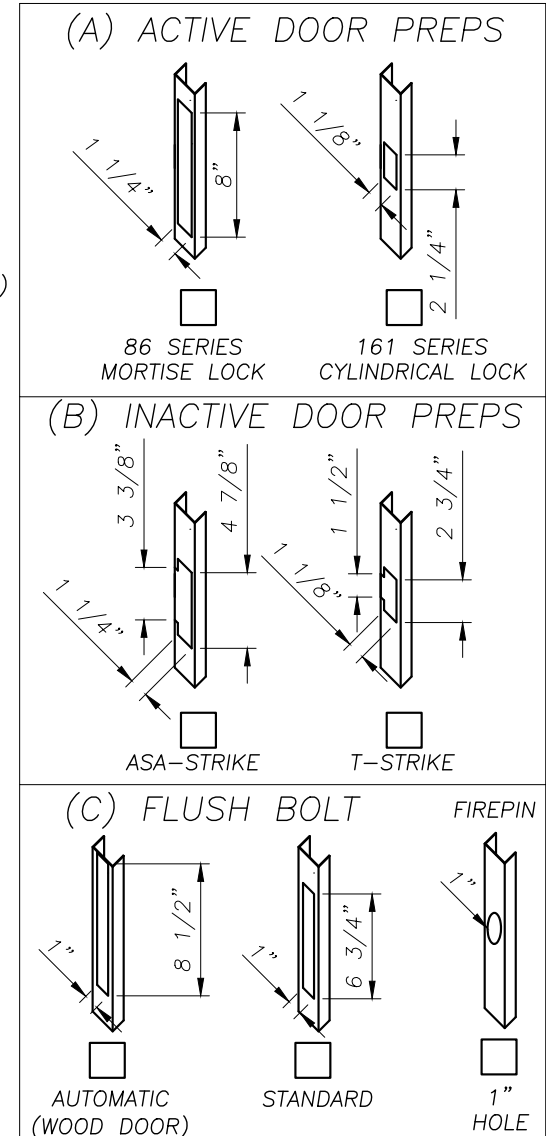

COMPANY:	
PO#:	DATE:
JOB NAME:	
MODEL #:	FINISH:
SIGNATURE:	

NOTE: SOME DEAD BOLT PREPS ARE AVAILABLE. PLEASE CONSULT FACTORY

- PLEASE COMPLETE steps 1 thru 3:
1. Quantity for each hand
  2. Hardware locations
  3. Select hardware preps

REV.DATE: 06/09/2017

# NOTES

---

# NOTES

---



For the most up-to-date  
Seals, Edges, Astragals &  
Specialty Products Catalog  
scan the QR code or visit  
ngp.com.



**ngp.com**  
**1-800-NGP-RUSH**

FAX: (800) 255-7874  
QUOTES: [quotes@ngp.com](mailto:quotes@ngp.com)  
ORDERS: [orders@ngp.com](mailto:orders@ngp.com)

**NGP MEMPHIS**  
4985 East Raines Road  
Memphis, TN 38118

**CARSON CITY**  
3689 Arrowhead Drive  
Carson City, NV 89706