

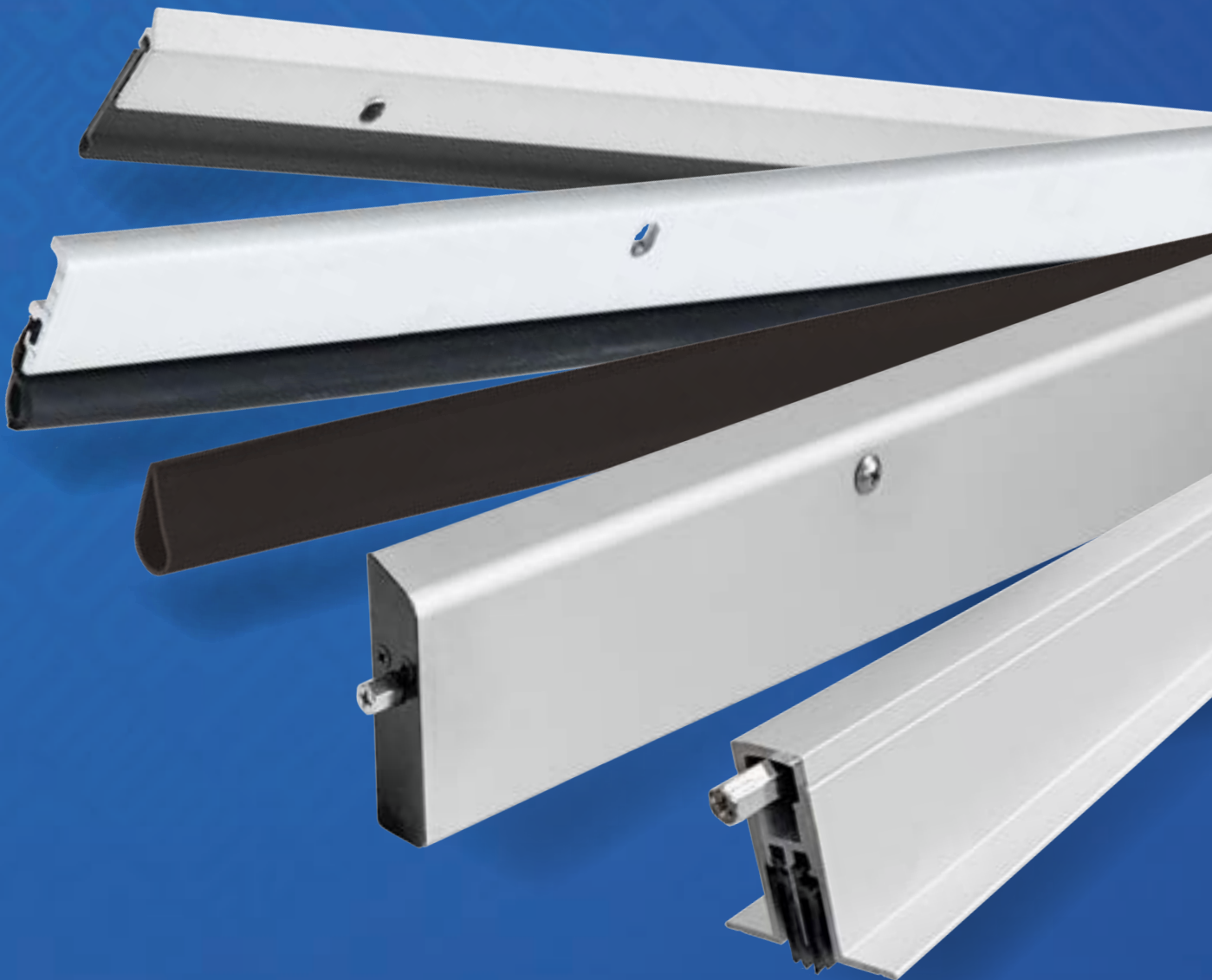

SEALS

GASKETING &
AUTOMATIC DOOR BOTTOMS





GASKETING INDEX:

Acoustical Door Shoes.....	G36
Adjustable Perimeter Seals.....	G30
Automatic Door Bottoms.....	G32-G35
Concealed Fastener Nylon Brush Sweeps.....	G44
Concealed Fastener Seals.....	G27
Door Bottom Seals.....	G47
Extended Door Shoes.....	G37
Finned Vinyl Door Shoes.....	G40
Foam Seals.....	G22
Gasketing Fasteners.....	G56
Guards/Seals.....	G55
Magnetic Astragal Sets.....	G50
Mortised Astragals.....	G53
Neoprene and Silicone Sweeps.....	G43
Neoprene Bulb Seals.....	G20
Neoprene Sponge Seals.....	G19
Neoprene, Nylon Brush, Double Fin Door Shoes.....	G39
NGP-Edge® Sealing System.....	G16-G17
Nylon Brush Seals.....	G23-G24
Nylon Brush Seals with EPDM Rubber Insert.....	G46
Nylon Brush Sweeps.....	G45
Overhead Door Bottom Seal.....	G47
Overlapping Astragals.....	G51
Perimeter Seals.....	G25-26
Polypropylene Pile Door Shoes.....	G38
Polypropylene Pile Seals.....	G18
Polyurethane Seals.....	G20
Safety Seal for Double-Acting Doors.....	G54
Seal for Mullion Applications.....	G12
Self-Adhesive Gasketing FATT.....	G12
Self-Adhesive Pile Astragals.....	G54
Self-Adhesive Silicone Gasketing.....	G13-G16
Silicone Seals.....	G21-G22
Smoke-Rated Astragal Seals.....	G48
Smooth Vinyl Door Shoes.....	G38
Solid Metal Astragals.....	G52
Specialty Astragal.....	G51
Spring Adjustable Astragal Sets.....	G50
Spring Adjustable Mortised Astragals.....	G54
Stainless Steel.....	G28-29
STC Rated Acoustical Foam Pad.....	G36
Steel Mounting Brackets.....	G31
Steel Security Astragals.....	G52
Surface Mounted Astragal Sets.....	G49
Thermoplastic Door Shoes.....	G41-G42
Vinyl Seals.....	G18
Vinyl Sweeps.....	G44

NUMERICAL INDEX:

3.....	G31	130N.....	G19	318V.....	G40	1038N.....	G30
5V.....	G38	130S.....	G21	319ET.....	G42	1390SP.....	G52
6V.....	G38	130SS.....	G28	319ET6.....	G41	1392SP.....	G52
7.....	G31	131N.....	G20	319EV.....	G40	2014R.....	G43
12T.....	G42	133N.....	G19	319V.....	G40	2525C.....	G14
12T6.....	G41	134N.....	G20	320.....	G34	5020.....	G16
12V.....	G38	134S.....	G22	331.....	G37	5040C.....	G14
13T.....	G42	135N.....	G20	335.....	G34	5050.....	G13
13T6.....	G41	136.....	G47, G53	336.....	G54	5050 Anti-Lig.....	G13
13V.....	G38	137N.....	G20, G48	340.....	G54	5060C.....	G14
14R.....	G47, G51	137S.....	G22, G48	344.....	G42	5070.....	G15, G48
15N.....	G39	139.....	G52	384.....	G22	5075.....	G15
16.....	G55	139SP.....	G52	420N.....	G33	5100.....	G12
16SS.....	G29	139SS.....	G28, G52	423N.....	G35	9115.....	G48
17.....	G55	140P.....	G50	423STC.....	G35	9125.....	G48
17SS.....	G29	140S.....	G50	520N.....	G33	9125SS.....	G28
18V.....	G38	143.....	G53	600.....	G24, G45, G49	9600.....	G48
19V.....	G38	144.....	G54	601.....	G25, G46	9605.....	G48
26N.....	G39	149M.....	G50	602.....	G23	9700.....	G26
35EV.....	G40	150U.....	G20	603.....	G23	9750C.....	G16
35ET.....	G42	151.....	G53	A605.....	G24, G45, G49	9800.....	G17
35ET6.....	G41	152S.....	G22	B606.....	G24, G45, G49	81369.....	G47
35V.....	G40	152V.....	G18	C607.....	G24, G45	FATT.....	G12
36ET.....	G42	155S.....	G22	D608.....	G24, G45		
36ET6.....	G41	155V.....	G18	G610.....	G24, G45		
36EV.....	G40	156S.....	G22	G611.....	G24		
36V.....	G40	156V.....	G18	H612.....	G24, G45		
43CB.....	G55	158.....	G51	H614.....	G24		
54CP.....	G12	159M.....	G55	I-615.....	G24		
60FP.....	G36	160S.....	G22	I-616.....	G24		
92.....	G37	160U.....	G20	D620.....	G23		
92T.....	G42	160V.....	G18	G622.....	G23		
92T6.....	G41	161N.....	G20	H623.....	G23		
95WH.....	G39	161S.....	G22	I-624.....	G23		
96V.....	G44	161U.....	G20	A625.....	G23		
97V.....	G44, G49	161V.....	G18	A626.....	G23		
99.....	G37	162S.....	G22	C627.....	G45		
99T.....	G42	164V.....	G18	OV633.....	G24, G45		
99T6.....	G41	165N.....	G19	OV634.....	G24, G45		
101V.....	G44	165S.....	G21	A635.....	G53		
102V.....	G43	170.....	G27	D648.....	G23		
103N.....	G30	172N.....	G20, G27	672.....	G27, G44, G49		
106.....	G30	172S.....	G22, G27	672N.....	G43, G48		
107.....	G30	172V.....	G18, G27	672P.....	G27		
108N.....	G19	176.....	G51	673.....	G44		
109N.....	G51	178.....	G51	674.....	G44		
110N.....	G19	185P.....	G18	675.....	G27, G44, G49		
110S.....	G21	197N.....	G43	678.....	G44		
112N.....	G39	198N.....	G43	679.....	G44		
113N.....	G39	199N.....	G43	680.....	G33		
114.....	G51	200N.....	G43	683.....	G35		
115N.....	G48	200S.....	G43	C697.....	G46		
118N.....	G39	200SS.....	G29	D698.....	G46		
119N.....	G39	201N.....	G43	C699.....	G46		
120N.....	G19	202N.....	G43	700E.....	G25		
120S.....	G21	203N.....	G43	700N.....	G26		
120SS.....	G28	220.....	G32	700S.....	G26		
122N.....	G19	222.....	G32	700U.....	G26		
125N.....	G48	225.....	G34	705EV.....	G25		
125SS.....	G28	229SS.....	G29, G32	705V.....	G26		
127N.....	G19	254P.....	G38	706E.....	G25		
127S.....	G21	312V.....	G40	896.....	G39		
127SS.....	G28	312V X 131N.....	G36	1000RA.....	G54		
129SS.....	G30	313V.....	G40	1015V.....	G44		

— FEATURING OUR —
PRODUCT CATEGORIES

SEALS

- Thresholds
- Gasketing
- Door Bottoms



LITES

- Lite Kits
- Louvers

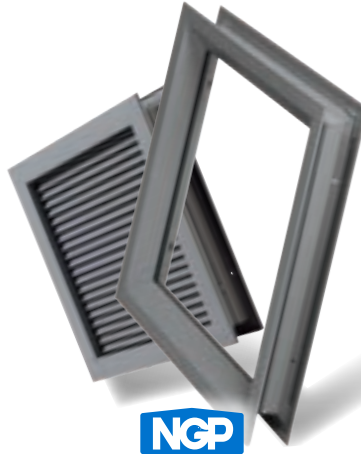

GLASS

- Fire
- Safety
- Specialty

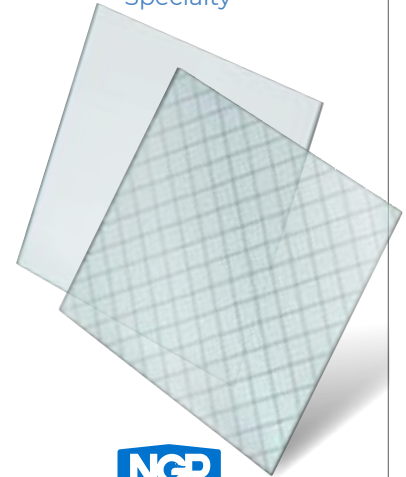

SLIDING

- Stainless Steel Barn Door Track
- Aluminum Track Systems
- Steel Flat Track



GAPGUARD

- Gap90
- 9590
- 9990



TECHNICAL INFORMATION

RATING SYMBOLS LEGEND



POSITIVE PRESSURE - CERTIFIED by UL to ANSI/UL10C Complies with IBC, NFPA 80 and NFPA 252 for application to hollow metal fire doors rated up to 3 hours, and wood fire doors rated up to 90 minutes (some ratings vary as noted).



CERTIFIED by UL to CAN/ULC-S104 and ANSI/UL10B Complies with NFPA 80 and NFPA 252 for application to hollow metal fire doors rated up to 3 hours, and wood fire doors rated up to 90 minutes (some ratings vary as noted).



NGP-EDGE® SEALING SYSTEM, CERTIFIED BY UL TO ANSI/UL10C CATEGORY 'G' Required for Category B wood fire doors to meet positive pressure requirements complying with IBC, and NFPA 252. See individual products for maximum door size and ratings.



SMOKE & DRAFT CONTROL GASKETING, CERTIFIED BY UL TO ANSI/UL10C AND ANSI/UL 1784 CATEGORY 'H' Complies with IBC and NFPA 105 for use on 'S' labeled positive pressure hollow metal fire doors rated up to 3 hours, and wood fire doors rated up to 90 minutes (some ratings vary as noted).



ACOUSTICAL TESTED to ASTM E90 Standard Test Method for Laboratory Measurement of Airborne Sound Transmission Loss of Building Partitions and Elements, and ASTM E2235 Standard Test Method for Determination of Decay Rates for use in Sound Insulation Test Methods.



AIR INFILTRATION Recommended product for minimum Air Leakage and a tight seal around the perimeter of doors.



ANSI/BHMA CERTIFIED Certified gasketing complies with American National Standard for Door Gasketing and Edge Seal Systems ANSI/BHMA A156.22, and is listed in the BHMA Certified Products Directory.



Online product listings: ul.com/database



BUY AMERICAN

REQUIREMENTS

Buy American Act

Over 99% of our products are produced in the United States as a domestic construction material, as defined in the Buy American Act (BAA) of March 1933 and amended by the Buy American Act of 1988 and FAR 52.225-9. A Buy American certificate may be obtained on our website ngp.com.

Build America, Buy America Act

Most of our products comply with Build America, Buy America Act requirements under Title IX of the Infrastructure Investment and Jobs Act (IIJA), Pub. L. 117-58, §§ 70901-70953. Contact us for a Certificate of Compliance for products being supplied on your project.

MATERIALS

Metal retainers for gasketing are Aluminum Alloy 6063, T5 or T6 temper, unless noted.

Architectural Bronze gasketing is Alloy CDA 385 (Copper Alloy No. C38500), Architectural Bronze.

Stainless steel gasketing is Type 304, known for its excellent corrosion resistance, high tensile strength and resistance to oxidation.

NGP utilizes a variety of gasketing materials including Vinyl, Neoprene, Silicone, Nylon Brush, Thermoplastic Elastomers (TPE), Thermoplastic Vulcanizates (TPV), Polypropylene Pile, Ethylene-Propylene-Diene-Monomer (EPDM), Polyurethane, and Intumescent Fire Seals. Product illustrations indicate the gasketing material. Properties of many primary gasket materials are listed on the Perimeter Seals catalog pages.

Adhesive mounted gasketing utilizes a pressure sensitive modified acrylic adhesive protected by a release liner. Once installed it provides a permanent bond in exterior or interior locations. End use temperature range is -30°F up to 250°F. Shelf life of adhesive prior to installation is one year when stored at 75°F and 50% relative humidity or less.

GASKETING FINISHES

Material	Finish	ANSI/BHMA Finish	US Finish	NGP Suffix
Aluminum:	Mill Finish	ANSI/BHMA 719	US27	None
	Anodized Aluminum	ANSI/BHMA 628	US28	A
	Black Anodized	ANSI/BHMA 711	US19	B
	Dark Bronze Anodized	ANSI/BHMA 710	313AN	DKB
	Polished	ANSI/BHMA 717		POL
Stainless Steel:	Brushed (#4)	ANSI/BHMA 630	US32D	None
Gasket Materials:	Neoprene is Black			N
	Polyurethane is Black			U
	Vinyl is Black			V
	Silicone is Black except where noted otherwise			S
	Thermoplastic is Brown			T, T6
	Nylon Brush colors: Black, Gray			
	Polypropylene Pile is Gray			P
EPDM is Black				

UNDERSTANDING SOUND TRANSMISSION CLASS



The Sound Transmission Class (STC) is a single-number rating of the ability of a material or an assembly to resist airborne sound transfer at the frequencies 125-4000 Hz. In general, a door system with a higher STC rating blocks more noise from transmitting through an opening.



VERY POOR
LOW SPEECH
AUDIBLE



POOR
NORMAL SPEECH
UNDERSTOOD EASILY
AND DISTINCTLY



FAIR
LOUD SPEECH
UNDERSTOOD
FAIRLY WELL



GOOD
LOUD SPEECH
HEARD BUT HARDLY
INTELLIGIBLE



VERY GOOD
LOUD SPEECH
HEARD FAINTLY



EXCELLENT
LOUD SOUNDS
HEARD FAINTLY
OR NOT AT ALL

SOURCE ROOM

80dB



SOUND PRESSURE LEVEL 80 DB

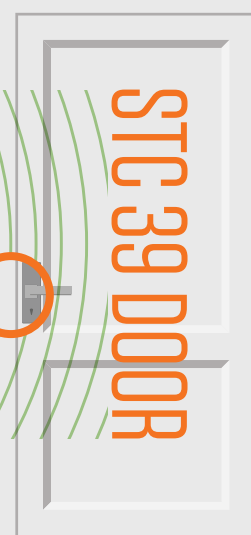

RECEIVING ROOM

41dB



SOUND PRESSURE LEVEL 41 DB

NOISE LEVELS

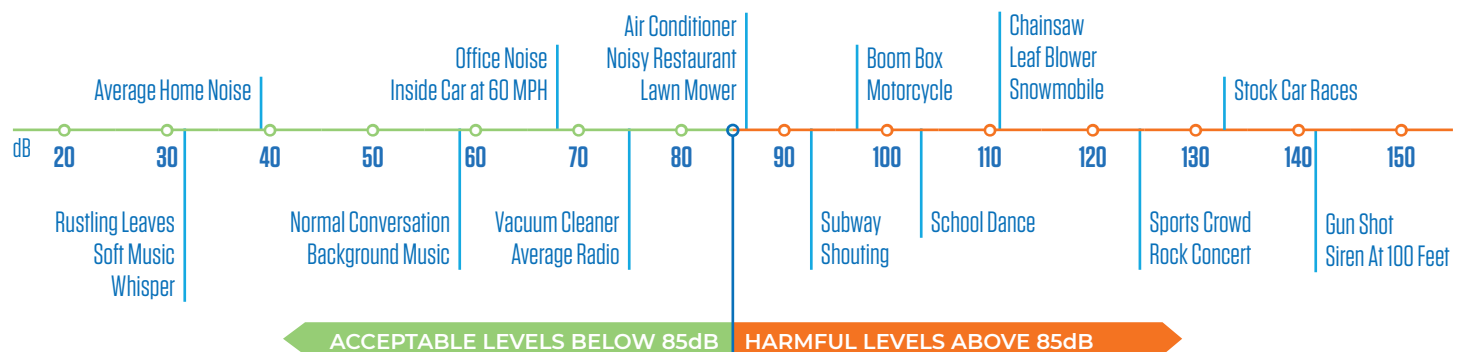

No matter what the STC door rating may be, it cannot perform without the proper STC Gasketing. Sound leaks from the perimeter of the door just like a draft of air.

STC SEAL SETS

SINGLE DOORS

NGP Seal Sets maintain the static door panel STC with NO DROP OFF in an operable condition, up to the STC Rating indicated.

STC Seal Set	STC Rating	Perimeter Seals at Heads & Jambs	Door Bottom	Corner Pads	Threshold
1	33	5050 & 2525	312V X 131N	60FP (2 req.)	8144S*
2	45	5075 & 5060	312V X 131N	60FP (2 req.)	8144S*
3	52	5075 & 5060	12T6 X STC-FH	60FP (2 req.)	8144S*
4	52	5075 & 5060	423STC	60FP (2 req.)	8144S*
5	52	5075 & 5060	None	None	896S-ADJ

STC Seal Set 4 Illustration

*optional

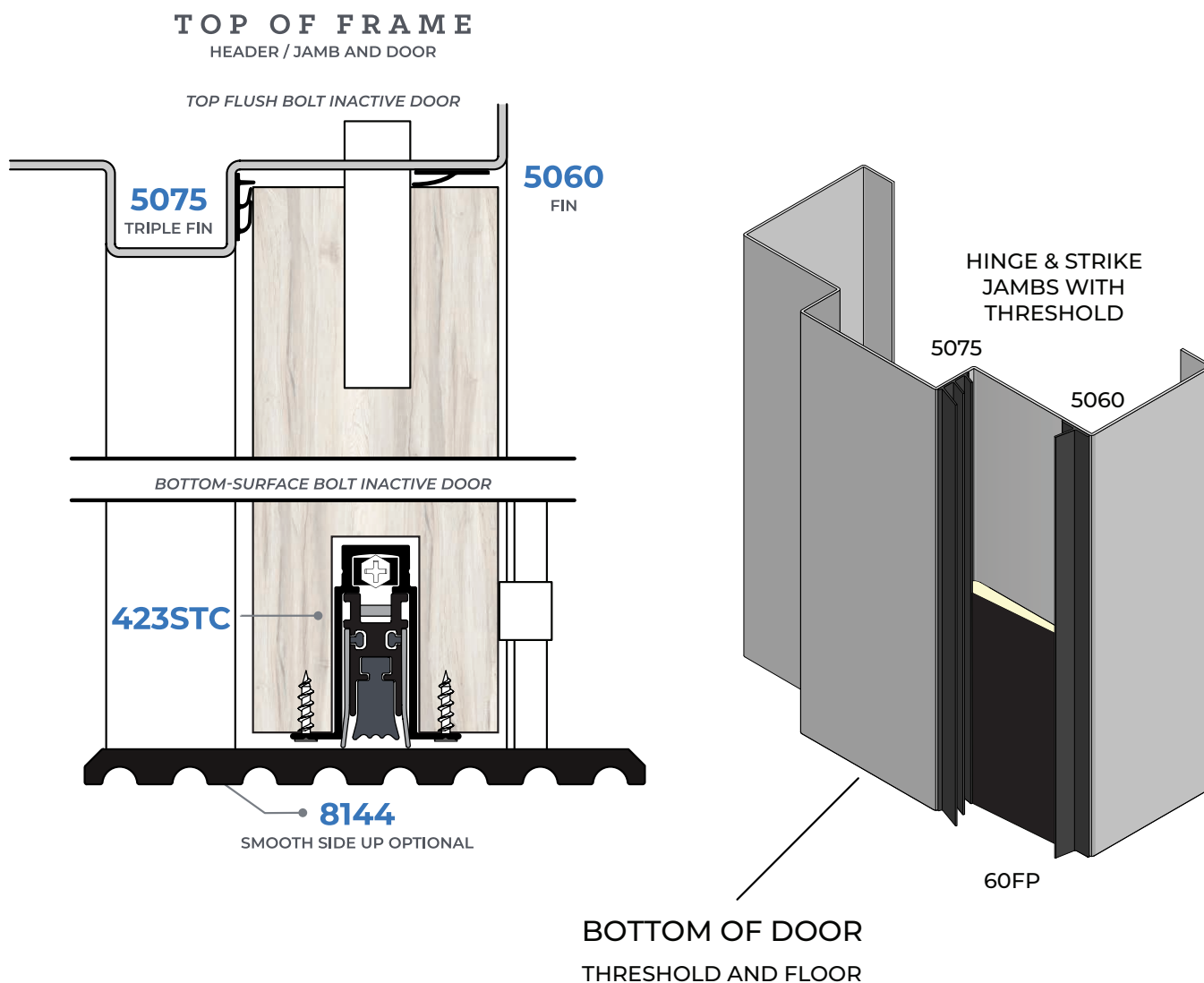

STC SEAL SETS

PAIRS OF DOORS

STC Seal Set	STC Rating	Perimeter Seals at Heads & Jambs	Door Bottom	Corner Pads	Meeting Edge Seals	Threshold
6	45	5075 & 5060	423STC	60FP (3 req.)	5060 (2 req.)	8144S*
7	45	5075 & 5060	12T6 X STC-FH	60FP (3 req.)	5060 (2 req.)	8144S*

STC Seal Set 6 Illustration

*optional

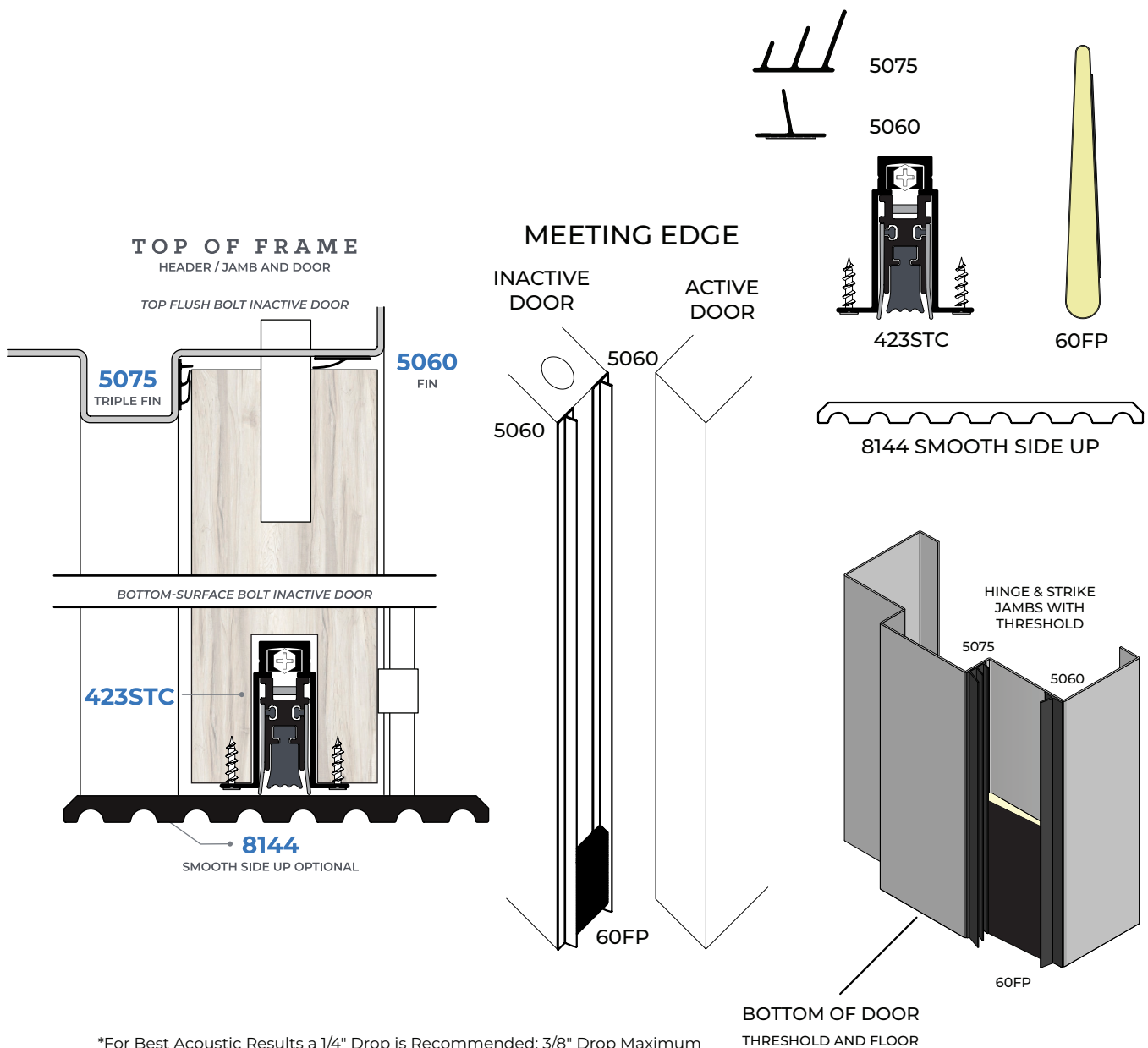

SOUND TRANSMISSION CLASS (STC) RATED PAIRS OF DOORS

STANDARD DOORS WITHOUT SPECIAL ACOUSTIC CORES

Solid core wood doors with gasketing test to an STC Rating of approximately 28 to 30. Mineral core wood doors and Honeycomb core hollow metal doors with gasketing test to an STC Rating of approximately 32 to 36. Without gasketing these doors have no sound control and test to an STC Rating between 15 and 20.

To most effectively reduce sound transmission and maximize the acoustic performance we recommend the following be used:

PERIMETER AND DOOR BOTTOMS

- 107S** Perimeter Seal
- 700S** Seal at Head if a Parallel Arm Closer is Used
- 220S** Automatic Door Bottom
(To Allow the Automatic Door Bottom to Properly Seal, Please Add a Threshold.)

MEETING EDGE OF PAIRS

- 109N** Overlapping Astragal
- 5070** Adhesive Astragal
- 115N** Astragal Set

SCHOOL CLASSROOM DOOR STC REQUIREMENTS

ANSI/ASA S12.60 Acoustical Performance Criteria, Design Requirements, and Guidelines for schools requires interior doors opening into core learning spaces to achieve STC 30 or greater in their operable condition and interior doors into music rooms at least STC 40.

The following interprets ANSI/BHMA numbers which identify type and function of products. For products that meet ANSI/BHMA Standards, look for the BHMA certified logo next to the product in our catalog. For a complete listing, refer to the BHMA Certified Products Directory, available online at buildershardware.com

ANSI/BHMA A156.22

AMERICAN NATIONAL STANDARD FOR DOOR GASKETING AND EDGE SEAL SYSTEMS

1 Product Section	2 Material Description	3 Gasketing Type Desc	4 Product Type Description	5 Gasketing Location Description	6 Gasketing Rating Description	
"R" designates Gasketing	1. Brass or Bronze 3. Aluminum 5. Stainless Steel 0. Optional Material or None Used	A. Brush B. Neoprene, Solid C. Neoprene, Expanded, Closed Cell D. Vinyl E. Silicone Rubber F. Pile G. Thermoplastic Elastomer (TPE) H. Thermoplastic Urethane (TPU) J. Thermoplastic Rubber K. Spring Metal L. Magnetic M. Felt N. Rubber Fabric P. Intumescent Q. Intumescent/Brush R. Intumescent/Neoprene, Solid	S. Intumescent/Neoprene, Expanded, Closed Cell T. Intumescent/Vinyl U. Intumescent/Silicone Rubber V. Intumescent/ Pile W. Intumescent/ Thermoplastic Elastomer (TPE) X. Intumescent/ Thermoplastic Urethane (TPU) Y. Optional Material or None Used Z. Intumescent/ Thermoplastic Rubber	1. Head & Jamb 2. Head & Jamb, Adjustable 3. Automatic Door Bottom 4. Door Sweep or Shoe 5. Door Sweep or Shoe with Drip Cap 6. Astragal, Overlapping 7. Astragal, Split or Compensating 8. Astragal, Adjustable 9. Rain Drip Without Gasket 10. Fire Glazing Tape 0. Other	1. Door Edge 2. Door Edge, Mortise 3. Door Face 4. Door Face, Semi-Mortise 5. Frame Rabbet (Surface or Mortise) 6. Frame Soffit (H.M.) 7. Frame Face 8. Kerf 9. Stop (H.M.), Stop Face (WD) 0. Other	1. Smoke/Energy Performance Rated 4. Smoke Rated 5. Energy Performance Rated 6. Not Rated

Grade Performance (Optional field separate from ANSI Number)

- 1 Grade 1
- 2 Grade 2
- 3 Grade 3

INTERNATIONAL BUILDING CODE (IBC)

The International Building Code (IBC) requires swinging fire doors to be tested in accordance with ANSI/UL 10C or NFPA 252, with the neutral pressure level established at 40 inches or less above the sill. This causes “positive pressure” forces against the door assembly above 40 inches.

The result is hot gases and smoke leak out between the door and frame above this level, posing a serious threat to life and safety; and on wood doors rapidly deteriorating the integrity of the door edges, requiring either a built-in or supplemental “edge sealing system” to pass the test.

Fire door assemblies in corridors and smoke barrier walls are required to be smoke and draft control assemblies tested in accordance with UL1784 allowing a maximum air leakage of 3 cubic feet per minute per square foot of door opening at ambient temperature (75°F) and elevated temperature (400°F). These assemblies require the letter “S” on the fire rating label of the door indicating compliance “when listed or labeled gasketing is also installed.”

Fire doors are classified into category A or B based upon their construction and edge sealing system requirements. Fire-rated gasketing is classified as follows:



Category G - Edge Sealing Systems



Category H - Smoke and Draft Control Gasketing



Category J - Gaskets other than Category G or H.

Category A Classified Fire Doors

Hollow Metal Fire-Rated Doors
Wood Fire-Rated Doors constructed with edge seals built-in during the manufacturing process.

Require Category H – Smoke and Draft Control Gasketing at **perimeter** and at **meeting edge of pairs** of “S” label doors in corridor locations or smoke barrier walls.

Require Category H – Smoke and Draft Control **door bottom seals** on “S” label doors where pressurization is provided to restrict smoke movement (typically controlled by HVAC system).

The following products are recommended UL Classified Category H for wood doors - 90 min. max., hollow metal doors - 3 hour max.



Perimeter: 2525, 5020, 5040, 5050, 5070, 5075



Meeting edge of pairs: 115N, 125N, 137N, 137S, 5070, 9115, 9125, 9600, 9605

Category B Classified Fire Doors

Wood Fire-Rated Doors that require the addition of a Category G classified edge sealing system in the field.

Require Category G – Edge Sealing System, at **perimeter** and at **meeting edge of pairs**.

Require Category H – Smoke and Draft Control Gasketing at **perimeter** and at **meeting edge of pairs** of “S” label doors in corridor locations or smoke barrier walls.

Require Category H – Smoke and Draft Control **door bottom seals** on “S” label doors where pressurization is provided to restrict smoke movement (typically controlled by HVAC system).

The following products are recommended UL Classified for both category G and H:



Perimeter 20 minute: 5050
Perimeter 45, 60, 90 minute: 9750

SELF-ADHESIVE GASKETING

FATT

FAST ATTACH TWO-WAY TAPE

- ▶ Fast Attach Two-Way Tape Provides an Easy and Effective Alternative for Gasketing Installation. Two-Way Tape is Applied to the Metal Housing Insuring a Quick and Easy Installation. Then for Security, 3 Tek-type Self-Drilling Screws are Provided to Further Secure Each Piece of Material to the Frame Stop. A No-Problem Installation With No Holes to Drill.
- ▶ To Order Add Suffix "FATT" to Product Number. See Price List for Products Available With this Feature.
- ▶ FATT IS NOT CLASSIFIED FOR USE ON FIRE DOORS.

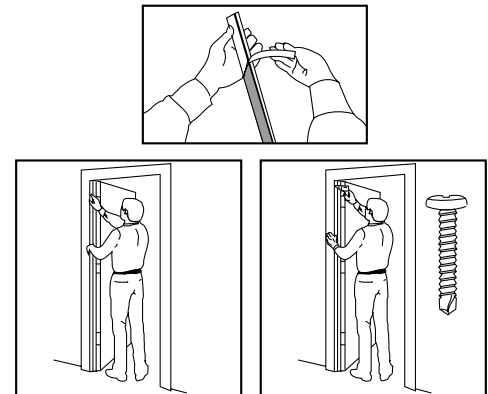

SEAL FOR MULLION APPLICATIONS

- ▶ Closed Cell Silicone Sponge Strip
1 1/8" Wide x 3/32" Thick With an Adhesive Strip for Mounting Directly to the Face of the Mullion That Doors Close Against
- ▶ Available in 86" and 96" Lengths
- ▶ Self-Adhesive: See Adhesive Specifications on Page G14

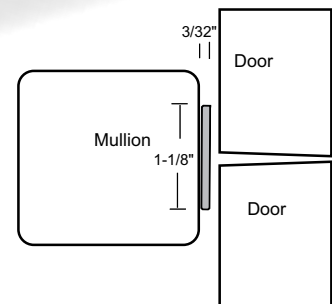

5100N Black Silicone

CORNER PAD

- ▶ Helps Acoustics and Seals Corner Gap for Air Leakage Control. Apply to Jamb on Hinge Side, Opposite Bottom Corner of Door Edge.
- ▶ Self-Adhesive: See Adhesive Specifications on Page G14

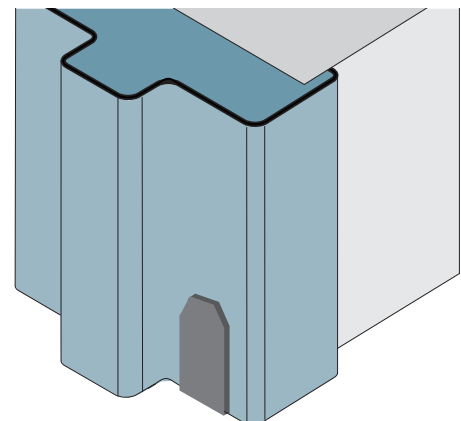
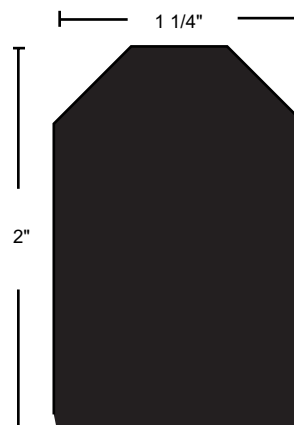

54CP Black Polypropylene Pile

SELF-ADHESIVE SILICONE GASKETING

SILICONE BULB FIRE AND SMOKE SEAL

- BHMA Certified to ANSI/BHMA A156.22 Performance Tests for Heat, Cold, Adhesive and Energy Performance



Edge Sealing System - Category G for 20 Minute Rated Category B Wood Doors Perimeter Application Up To:

Single Swing 4'0 X 8'0
 Pairs 8'0 X 8'0
 Use 9800 at the Meeting Edge of Pairs



Smoke and Draft Control - Category H
 Up To 3 Hours Hollow Metal Fire Doors
 Up To 90 Minutes Wood Fire Doors
 Use 5070 at the Meeting Edge of Pairs



STC 33

Meets Requirements of RoHS Directive
 See Adhesive Specifications on Page G14

5050B	Brown
5050C	Charcoal
5050W	White
5050CL	Clear

Available in 17', 20', 21', 25' and 300* Rolls
 *Clear Not Available in 300' Rolls

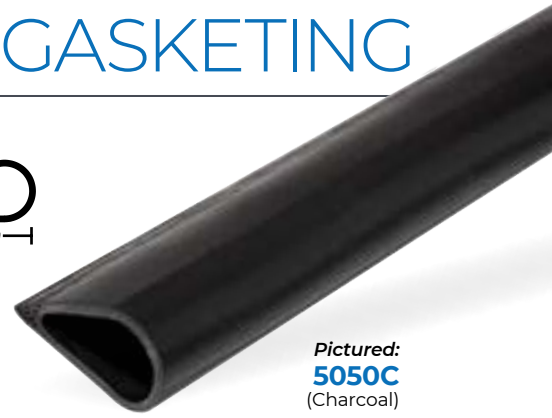
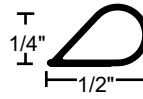

Pictured:
5050C
 (Charcoal)

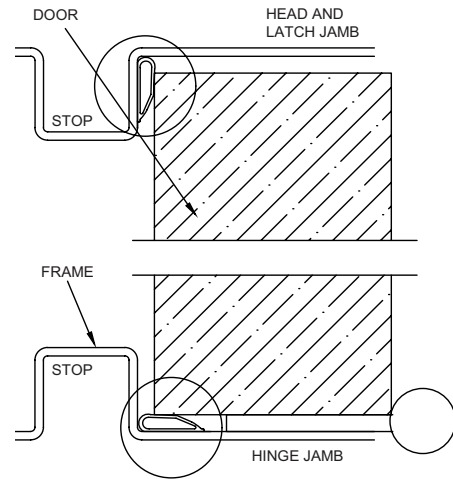

LIGATURE-RESISTANT SILICONE BULB FIRE AND SMOKE SEAL

- Ligature-Resistant Feature has Serrations Every 8" Designed to Break Apart Preventing it From Being Used to Hang or Strangle
- Applications Include Psychiatric Facilities, Prisons and Other Treatment Facilities
- Installs as a Continuous Length Providing the Same Sealing Properties for Light, Sound, Air and Smoke as Our Original 5050
- BHMA Certified to ANSI/BHMA A156.22 Performance Tests for Heat, Cold, Adhesive and Energy Performance

ANTI-LIG 5050C Charcoal

Available in 17' and 300' Rolls



Edge Sealing System - Category G for 20 Minute Rated Category B Wood Doors Perimeter Application Up To:

Single Swing 4'0 X 8'0
 Pairs 8'0 X 8'0
 Use 9800 at the Meeting Edge of Pairs



Smoke and Draft Control - Category H Up To 3 Hours Hollow Metal Fire Doors Up To 90 Minutes Wood Fire Doors
 Use 5070 at the Meeting Edge of Pairs



Meets Requirements of RoHS Directive
 See Adhesive Specifications on Page G14

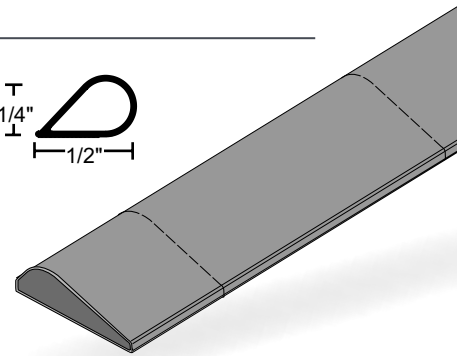
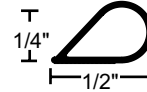

SELF-ADHESIVE SILICONE GASKETING

SILICONE BULB SMOKE SEAL

- BHMA Certified to ANSI/BHMA A156.22 Performance Tests for Heat, Cold, Adhesive and Energy Performance

Available in 17', 20', 21', 25', 300' Rolls



2525C Charcoal

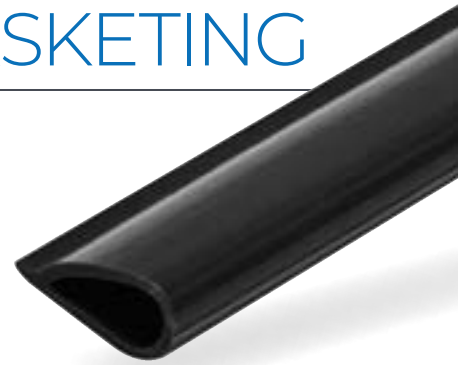
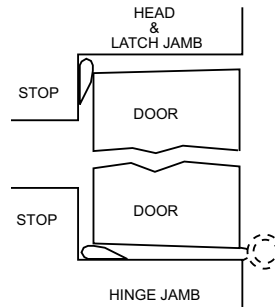
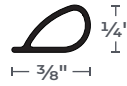

SILICONE FIN SMOKE SEAL

- BHMA Certified to ANSI/BHMA A156.22 Performance Tests for Heat, Cold, Adhesive and Energy Performance

Available in 17', 20', 21', 25', 300' Rolls



5040C Charcoal

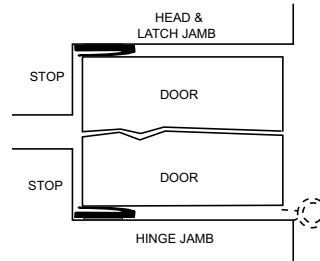
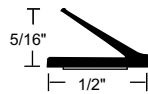

SILICONE FIN SMOKE SEAL

- BHMA Certified to ANSI/BHMA A156.22 Performance Tests for Heat, Cold, Adhesive and Energy Performance

Available in 17', 20' and 21' Rolls



5060C Charcoal

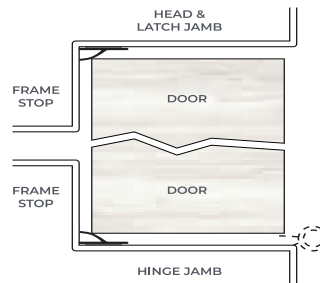
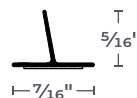

ADHESIVE SPECIFICATIONS

Modified acrylic pressure sensitive adhesive protected by release liner. Provides high initial adhesion and long-term holding power for permanent mounting in exterior or interior locations. Resistant to aging, weathering, UV radiation, water, detergent, alcohol and the influence of chemicals. End use temperature range, long term exposure -30°F up to 250°F. Shelf life of adhesive prior to installation is one year when stored at 75°F and 50% relative humidity or less.

SELF-ADHESIVE SILICONE GASKETING

PROPERTIES:

- Self-Adhesive Silicone Rubber
- Good Abrasion Resistance
- BHMA Certified to ANSI/BHMA A156.22 Performance Tests for Heat, Cold, Adhesive and Energy Performance

- Adhesive Specifications Shown on Page G14



Pictured:
5075C
(Charcoal)

FLEXIBLE TRIPLE FIN SMOKE SEAL

Available in 17', 20', 21', 25" and 300' Rolls

*White Only Available in 17' Rolls

**Clear Unavailable in 300' Rolls



5075C	Charcoal
5075CL	Clear**
5075W	White*

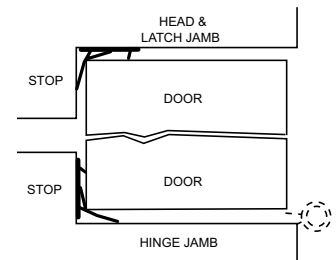
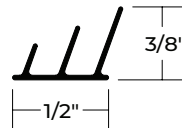

SILICONE DOUBLE SHARK FIN SMOKE SEAL

Smoke-Rated for Perimeter and/or Meeting Edge

Astragal Applications

Available in 4', 7', 8' and 9' Lengths



5070B	Brown
5070CL	Clear

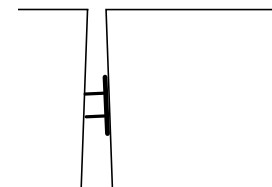
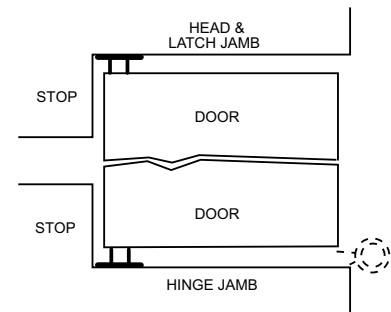
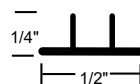

Astragal Application
Pair of Doors

SELF-ADHESIVE SILICONE GASKETING

PROPERTIES:

- ▶ Self-Adhesive Silicone Rubber
- ▶ Good Abrasion Resistance
- ▶ Moisture-Resistant
- ▶ BHMA Certified to ANSI/BHMA A156.22 Performance Tests for Heat, Cold, Adhesive and Energy Performance
- ▶ Flame-Resistant
- ▶ REACH and RoHS Compliant
- ▶ Adhesive Specifications Shown on Page G14



Pictured:
5020C
(Charcoal)

SILICONE BATWING SMOKE SEAL

Available in 4' and 9' Rolls



5020C	Charcoal
5020CL	Clear

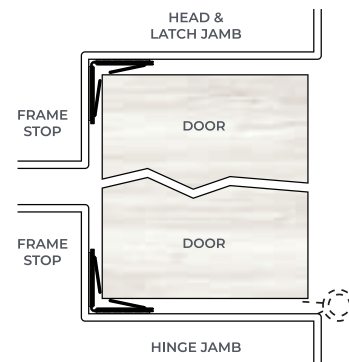
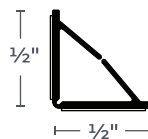

NGP-EDGE® SEALING SYSTEM

INTUMESCENT WITH FLEXIBLE ELASTOMERIC BULB FIRE AND SMOKE SEAL

 **20, 45, 60, 90 Minute Rated Category B Wood Doors Perimeter**
Application Up To:
 Single Swing 4'0 X 9'0
 Pairs 8'0 X 9'0

1/8" Clearance Required Between Door and Frame

Available in 36", 48", 84", 96" and 108" Lengths

Self-Adhesive: See Adhesive Specifications on Page G14



9750C	Charcoal
--------------	----------

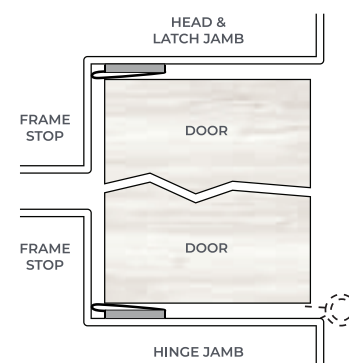
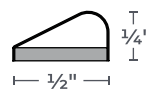

Pictured:
9750C
(Charcoal)

NGP-EDGE® SEALING SYSTEM

CATEGORY G CLASSIFIED

NGP Intumescent materials are formulated to expand at 375°F to 400°F up to 8-10 times their original thickness; completely sealing the gap around and between doors during a fire.

INTUMESCENT FIRE SEAL

Perimeter Application:



20, 45, 60, 90 Minute Rated Category B Wood Doors Up To:

Single Swing 4'0 X 9'0
Pairs 8'0 X 9'0

Meeting Edge Application Up To 8'0 X 9'0 Pairs of Category B Wood Doors:



20 Minute Rated with Single Strip Installed



45, 60 Minute Rated with Two Strips Installed

Intumescent With Protective Skin

Sold by the Foot: 3' Minimum to 490' Reel

Self-Adhesive: See Adhesive Specifications on Page G14

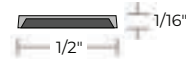

Pictured:
9800C
(Charcoal)



9800GR Gray

9800C Charcoal

VINYL SEALS

All Vinyl Seals This Section:



- Thermo-Plastic Vulcanizate (TPV)
- Economical
- Flame-Resistant
- Moisture-Resistant
- Temperature Range -40°F to 250°F
- #6 x 3/4" Stainless Steel Sheet Metal Screws Furnished
- Screw Holes Slotted for Adjustment
- Vinyl is Black

160VA
Anodized Aluminum
Vinyl Perimeter Seal

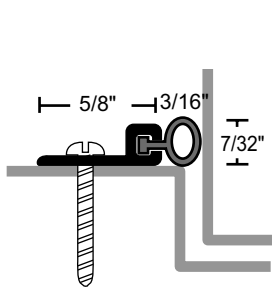

155V
155VDKB

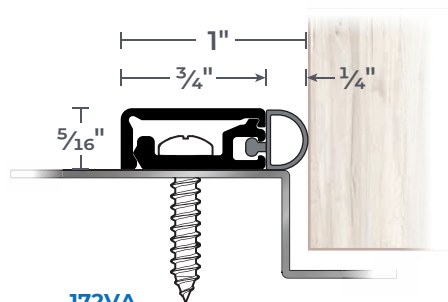

172VA
172VDKB

PRODUCT# SUFFIX	FINISH
A	Anodized Aluminum
DKB	Dark Bronze / Black Anodized
None	Mill Aluminum

Vinyl is Black
-GR = Gray Vinyl

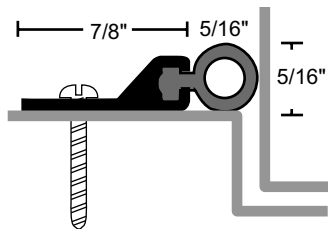

161V
161VDKB

.07 Aluminum for Military Specs

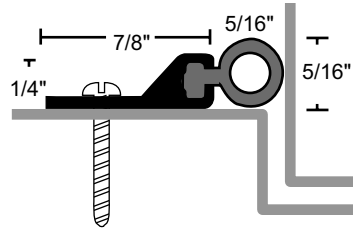

- | | | |
|----------------|-------------------|----------------|
| 152V | 160V | 164V |
| 152VA | 160V-GR | 164VA |
| 152VDKB | 160VA | 164VDKB |
| 156V | 160VA-GR | |
| 156VDKB | 160VDKB | |
| | 160VDKB-GR | |

POLYPROPYLENE PILE SEALS

- Temperature Range 32°F to 275°F
- Pile is Gray

185P
185PA
185PDKB

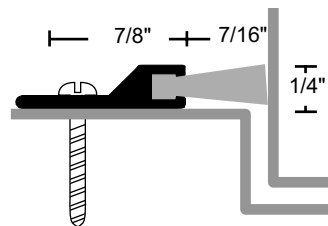

NEOPRENE SPONGE SEALS

All Products on This Page:



- ◆ Synthetic EPDM Rubber in Polypropylene Thermoplastic Matrix Closed Cell Advanced Elastomeric Foam
- ◆ Very Good Abrasion Resistance, Tensile Strength and Memory
- ◆ Flame-Resistant
- ◆ Moisture-Resistant
- ◆ Temperature Range -81°F to 275°F
- ◆ Good Resistance to Ozone, Sunlight and Aging
- ◆ BHMA Certified to ANSI/BHMA A156.22 Performance Tests for Heat and Cold
- ◆ #6 x 3/4" Stainless Steel Sheet Metal Screws Furnished
- ◆ Screw Holes Slotted for Adjustment
- ◆ Patent Pending Microcellular EPDM

108NA
Anodized Aluminum
Neoprene Sponge
Seal



PRODUCT#	SUFFIX	FINISH
	A	Anodized Aluminum
	DKB	Dark Bronze / Black Anodized

Neoprene is Black

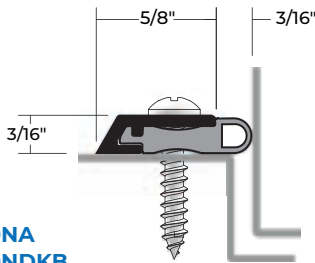

110NA
110NDKB
Patent Pending
BHMA
CERTIFIED

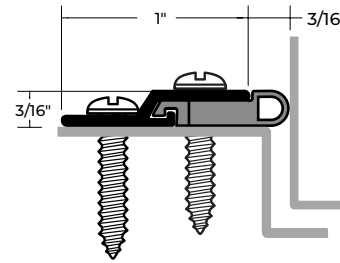

120NA
120NDKB
Patent Pending
BHMA
CERTIFIED

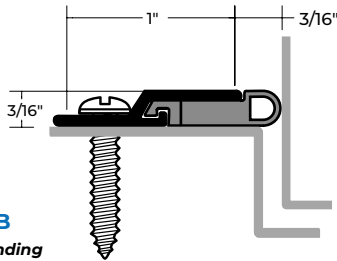

127NA
127NDKB
Patent Pending
BHMA
CERTIFIED

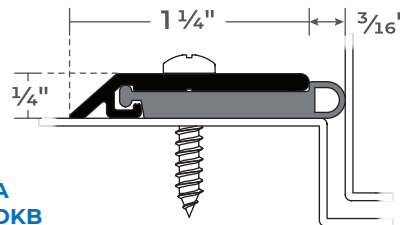

130NA
130NDKB
Patent Pending
BHMA
CERTIFIED

122NA
122NDKB
133NA
133NDKB
165NA
165NDKB
BHMA
CERTIFIED

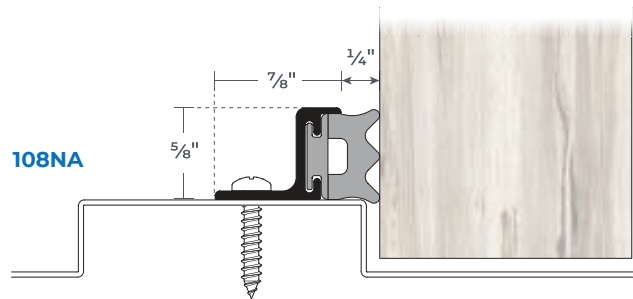
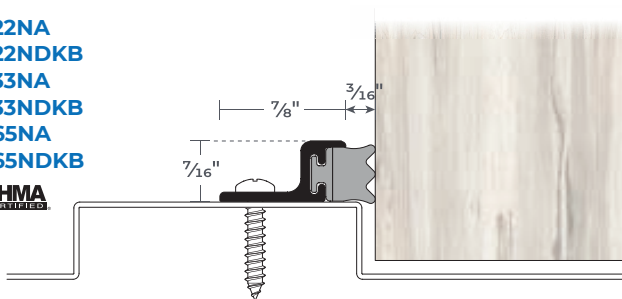

NEOPRENE BULB SEALS

All Neoprene Seals This Section:



- ▶ Synthetic EPDM Rubber in Polypropylene Thermoplastic Matrix
- ▶ Very Good Abrasion Resistance, Tensile Strength and Memory
- ▶ Flame-Resistant
- ▶ Moisture-Resistant
- ▶ Temperature Range -81°F to 275°F
- ▶ Good Resistance to Ozone, Sunlight and Aging
- ▶ BHMA Certified to ANSI/BHMA A156.22 Performance Tests for Heat and Cold
- ▶ #6 x 3/4" Stainless Steel Sheet Metal Screws Furnished
- ▶ Screw Holes Slotted for Adjustment

137NA
Anodized Aluminum
Neoprene Bulb
Perimeter Seal



PRODUCT#	SUFFIX	FINISH
	A	Anodized Aluminum
	DKB	Dark Bronze / Black Anodized
	None	Mill Aluminum

*Neoprene is Black
Polyurethane is Black*

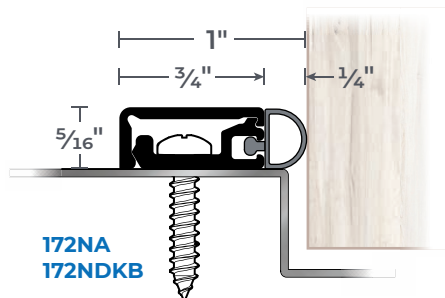
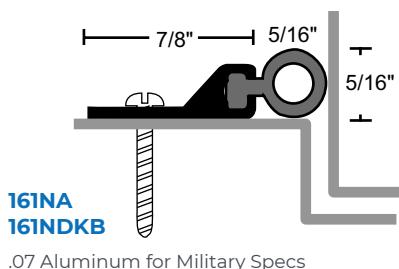
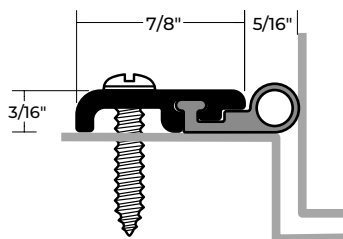
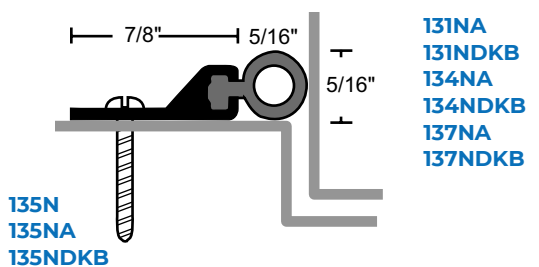

All Polyurethane Seals this Section:



POLYURETHANE SEALS

- ▶ Very Good Abrasion Resistance, Tensile Strength, Memory and UV Resistance
- ▶ Flame-Resistant
- ▶ Moisture-Resistant
- ▶ Temperature Range -76°F to 275°F
- ▶ #6 x 3/4" Stainless Steel Sheet Metal Screws Furnished
- ▶ Screw Holes Slotted for Adjustment

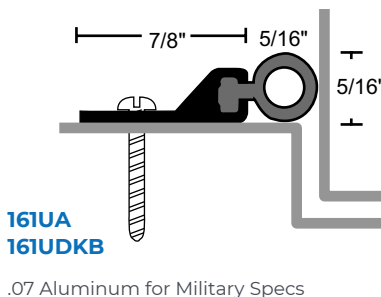
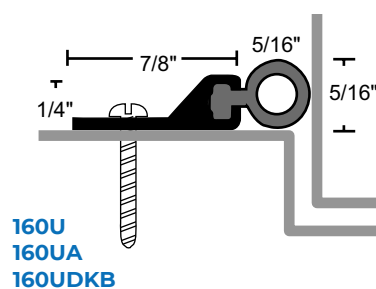
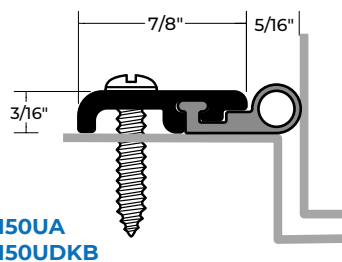

SILICONE SEALS

All Products on This Page:



- ▶ Synthetic Rubber Polymer: Closed Cell Sponge
- ▶ Excellent Flexibility and Memory
- ▶ Flame-Resistant
- ▶ Moisture-Resistant
- ▶ Temperature Range -81°F to 300°F, Remains Flexible at Extreme Temperatures
- ▶ Excellent Resistance to Ozone, UV and Aging
- ▶ Recommended for Areas Using FM200 or Halon Fire Suppression Systems
- ▶ BHMA Certified to ANSI/BHMA A156.22 Performance Tests for Heat and Cold
- ▶ #6 x 3/4" Stainless Steel Sheet Metal Screws Furnished
- ▶ Screw Holes Slotted for Adjustment
- ▶ Patent Pending Microcellular Silicone

110SA
Anodized Aluminum
Silicone Sponge Seal



PRODUCT#	
SUFFIX	FINISH
A	Anodized Aluminum
DKB	Dark Bronze / Black Anodized
None	Mill Aluminum

Silicone Sponge is Black

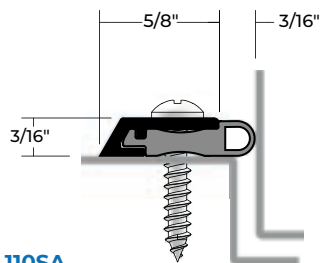

110SA
110SDKB
Patent Pending

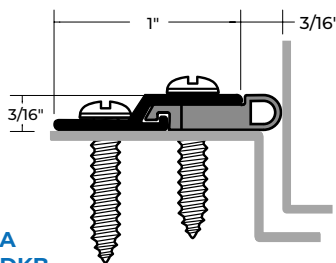

120SA
120SDKB
Patent Pending

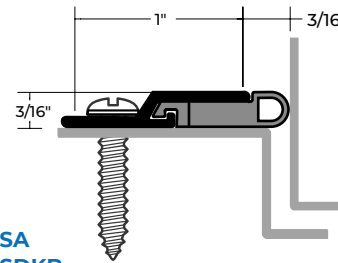

127SA
127SDKB
Patent Pending

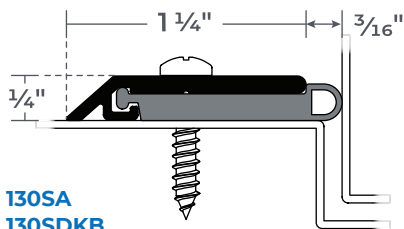

130SA
130SDKB
Patent Pending

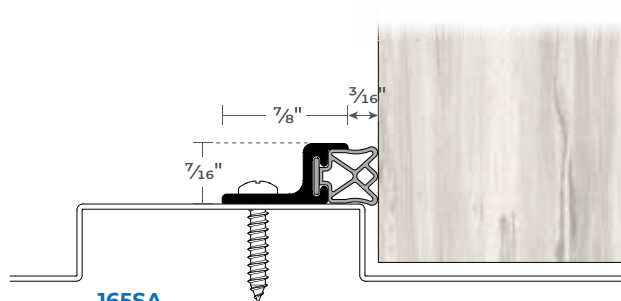

165SA
165SDKB

SILICONE SEALS

All Silicone Seals This Section:



- ▶ Synthetic Rubber Polymer
- ▶ Excellent Flexibility and Memory
- ▶ Flame-Resistant
- ▶ Moisture-Resistant
- ▶ Temperature Range -81°F to 300°F, Remains Flexible at Extreme Temperatures
- ▶ Excellent Resistance to Ozone, UV and Aging
- ▶ Recommended for Areas Using FM200 or Halon Fire Suppression Systems
- ▶ BHMA Certified to ANSI/BHMA A156.22 Performance Tests for Heat and Cold
- ▶ #6 x 3/4" Stainless Steel Sheet Metal Screws Furnished
- ▶ Screw Holes Slotted for Adjustment

137SA
Anodized Aluminum
Silicone Dense Bulb
Perimeter Seal



PRODUCT# SUFFIX	FINISH
A	Anodized Aluminum
DKB	Dark Bronze / Black Anodized
None	Mill Aluminum

Dense Silicone is Black

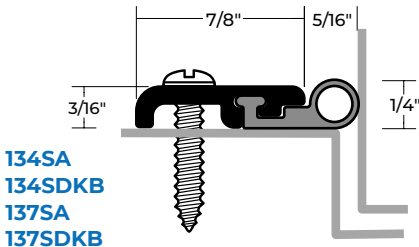

134SA
134SDKB
137SA
137SDKB

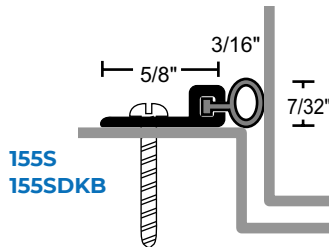

155S
155SDKB

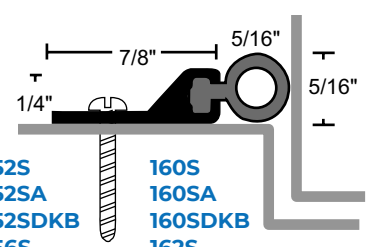

152S
152SA
152SDKB
156S
156SDKB

160S
160SA
160SDKB
162S
162SA
162SDKB

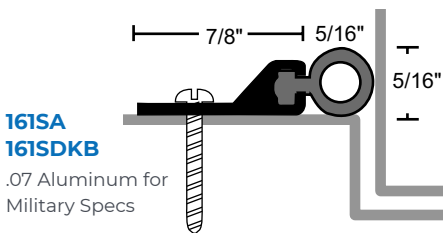

161SA
161SDKB
.07 Aluminum for Military Specs

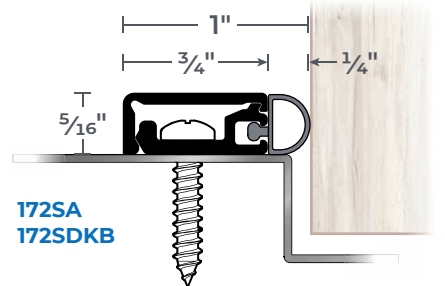

172SA
172SDKB

FOAM SEALS

- ▶ Seamless Compression Seals Are Nearly 100% Closed Cell to Prevent Water From Penetrating Foam Cell Structure
- ▶ Extruded Skin Provides a Unique UV Resistant Barrier With Design Features that Enhance the Weather Strip's Sealing Performance
- ▶ Compression: Recommended = 25% Minimum = 10% Maximum = 50%
- ▶ Achieves AAMA 702 Class "A" Extra High Performance Certification

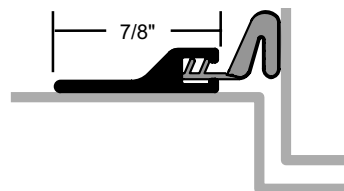

PRODUCT#	INSERT	FINISH
384B	Brown	Mill
384BA	Brown	Anodized
384BDKB	Brown	D. Bronze

NYLON BRUSH SEALS

- ▶ Synthetic Polymer: Polyamide
- ▶ Excellent Abrasion Resistance, Flexibility and Memory
- ▶ Moisture-Resistant
- ▶ Retains Insecticides Well
- ▶ Temperature Range -70°F to 425°F
- ▶ BHMA Certified to ANSI/BHMA A156.22 Performance Tests for Heat and Cold, in Most Common Profiles as Indicated by BHMA Certified Symbol
- ▶ REACH and RoHS Compliant
- ▶ Not Effective Against Water Penetration
- ▶ #6 x 3/4" Stainless Steel Sheet Metal Screws Furnished
- ▶ Screw Holes Slotted for Adjustment

PRODUCT# SUFFIX	INSERT	FINISH
A	Gray Brush*	Anodized Aluminum
DKB	Black Brush	Dark Bronze / Black Anodized
None	Gray Brush*	Mill Aluminum

-BB = Black Brush

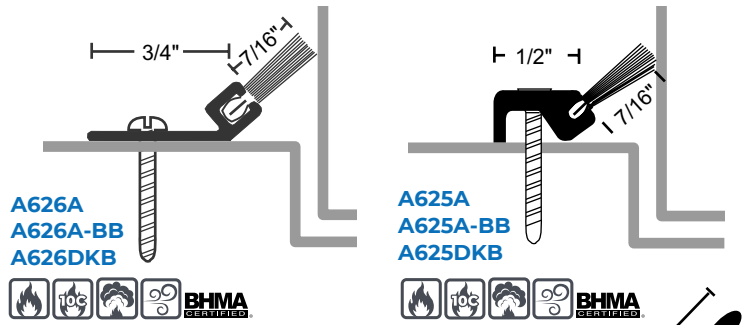

603A
603A-BB
603DKB

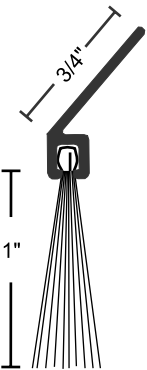

602A
602A-BB
602DKB

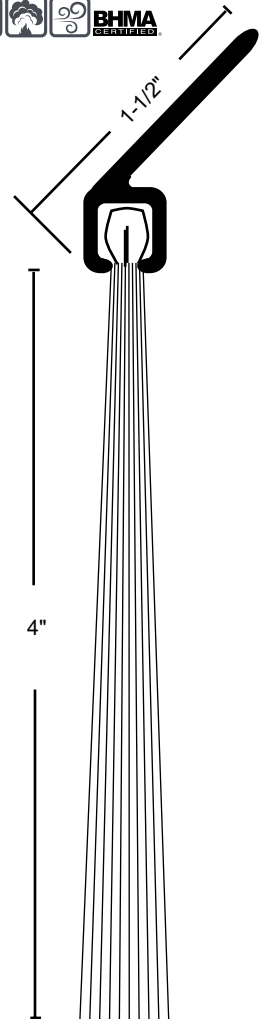
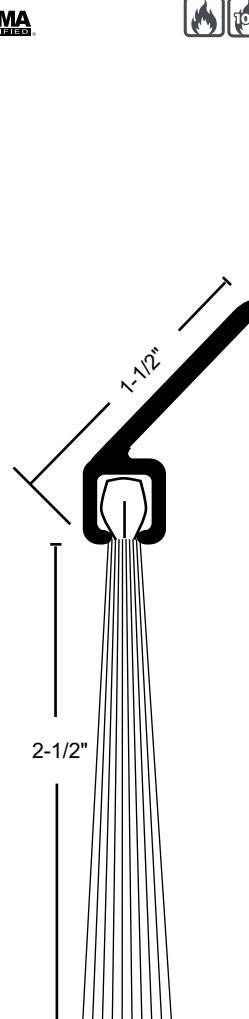
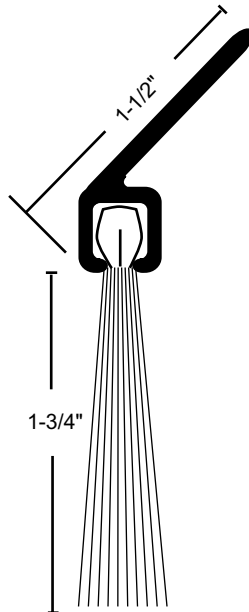
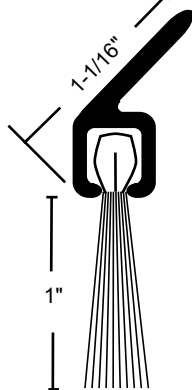
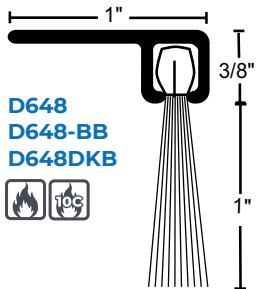
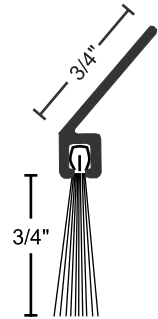

* Up To 3 Hours Metal Doors,
1 Hour Wood Doors

NYLON BRUSH SEALS

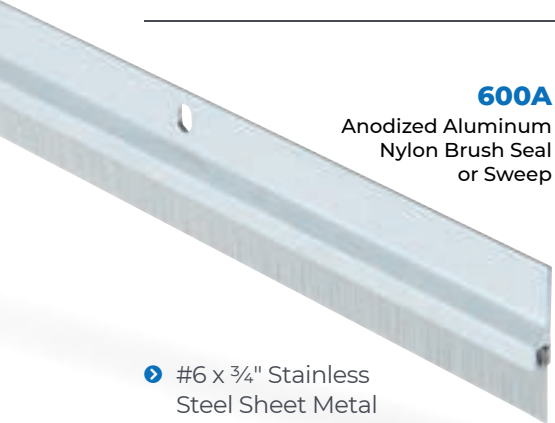

600A
Anodized Aluminum
Nylon Brush Seal
or Sweep

▶ #6 x 3/4" Stainless Steel Sheet Metal Screws Furnished. Screw Holes Slotted for Adjustment.

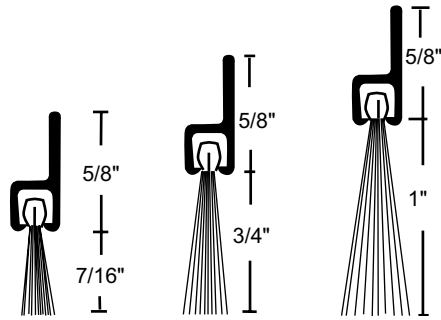

A605A
A605A-BB
A605DKB

OV634A
OV634A-BB
OV634DKB

OV633A
OV633A-BB
OV633DKB

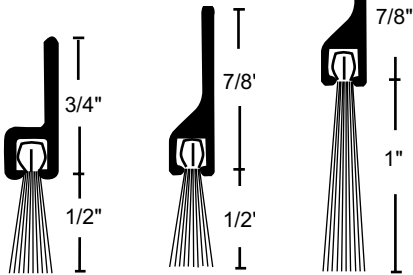

B606A
B606A-BB
B606DKB

600
600-BB
600A
600A-BB
600DKB

601
601-BB
601A
601A-BB
601DKB

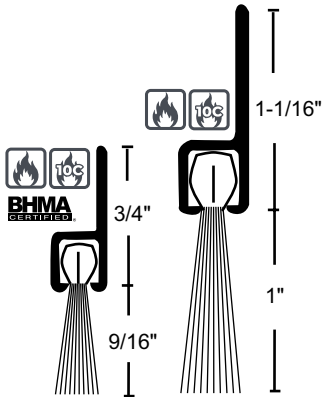
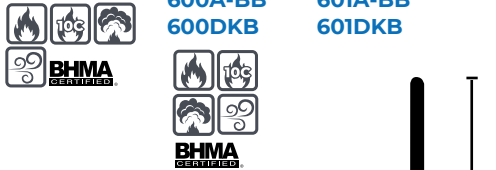

C607A
C607A-BB
C607DKB

D608A
D608A-BB
D608DKB

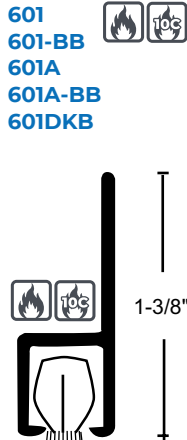

G610A
G610A-BB
G610DKB

H612A
H612A-BB
H612DKB

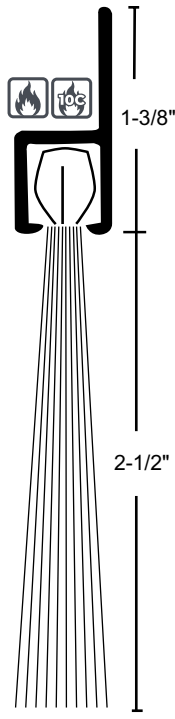

I-615A
I-615A-BB
I-615DKB

G611A
G611A-BB
G611DKB

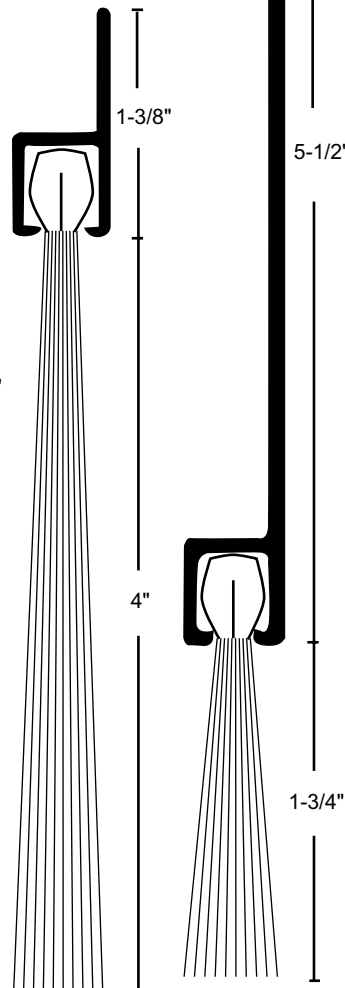

H614A
H614A-BB
H614DKB

I-616A
I-616A-BB
I-616DKB

PERIMETER SEALS

COMPATIBLE WITH PARALLEL ARM CLOSERS

- ▶ No Break in Seal for Closer Mounting
- ▶ Closer and/or Overhead Holder Attach to Frame Through Weatherseal Section. Install Seal First
- ▶ Allows Mounting of Rim Exit Device Strikes Without Notching Gasketing
- ▶ Head Section Not Drilled
- ▶ Jamb Sections Furnished With Slotted Holes for Adjustment
- ▶ Self-Drilling #8 (Tek-type) Screws Furnished



700ES
Mill Aluminum
Silicone Perimeter Seal

PRODUCT# SUFFIX	FINISH
A	Anodized Aluminum
DKB	Dark Bronze / Black Anodized
None	Mill Aluminum

Vinyl, Neoprene, Silicone and Polyurethane are Black -BB = Black Brush

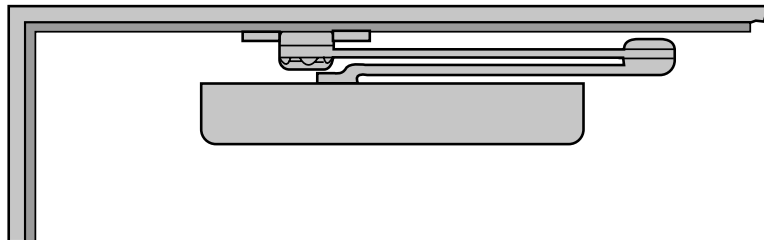

1-1/2" 15/16"
T 1/4"

neoprene

700EN
700ENDKB

1-1/2" 15/16"
T 1/4"

silicone

700ES
700ESDKB

1-1/2" 15/16"
T 1/4"

polyurethane

700EU
700EUDKB

1-1/2" 15/16"
T 1/4"

vinyl

705EV
705EVDKB

1-1/2" 7/16"
T 1/4"

nylon brush

706E Gray Brush
706E-BB Black Brush

PERIMETER SEALS

COMPATIBLE WITH PARALLEL ARM CLOSERS

- ▶ No Break in Seal for Closer Mounting
- ▶ Closer and/or Overhead Holder Attach to Frame Through Weatherseal Section. Install Seal First
- ▶ Allows Mounting of Rim Exit Device Strikes Without Notching Gasketing
- ▶ Head Section Not Drilled
- ▶ Jamb Sections Furnished With Slotted Holes for Adjustment
- ▶ Self-Drilling #8 (Tek-type) Screws Furnished

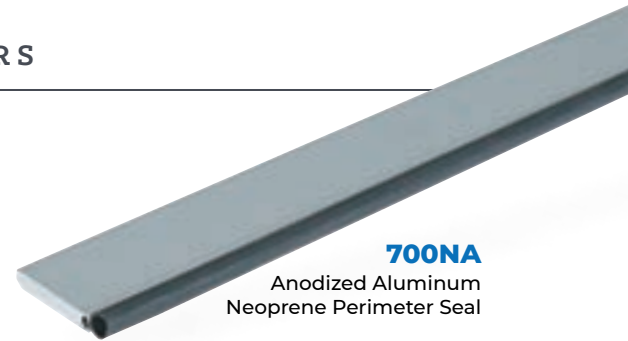

700NA

Anodized Aluminum
Neoprene Perimeter Seal

PRODUCT#	SUFFIX	FINISH
	A	Anodized Aluminum
	DKB	Dark Bronze / Black Anodized
	None	Mill Aluminum

Vinyl, Neoprene, Silicone and Polyurethane are Black

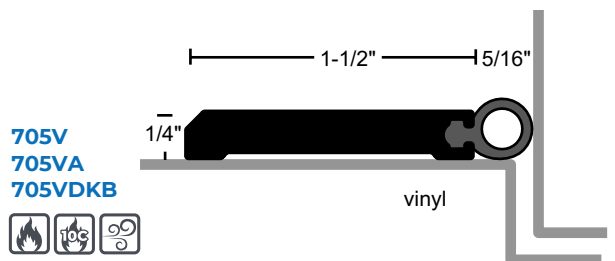
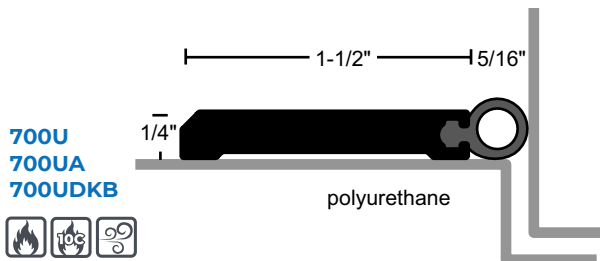
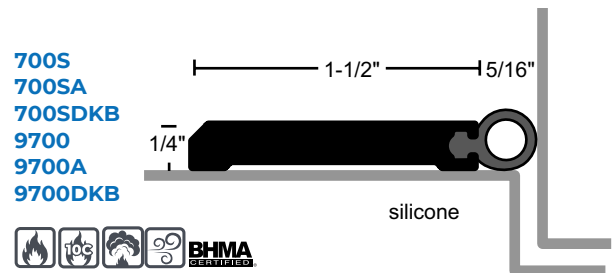
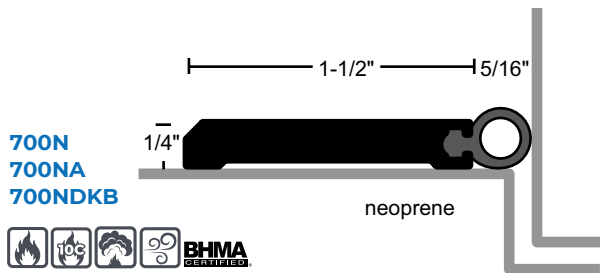

CONCEALED FASTENER SEALS

- ▶ Snap-On Cover Conceals Screw Heads for Clean Appearance
- ▶ #6 x 3/4" Stainless Steel Sheet Metal Screws Furnished
- ▶ Screw Holes Slotted for Adjustment

172NA

Anodized Aluminum
Neoprene Perimeter
Seal with Concealed
Fastener

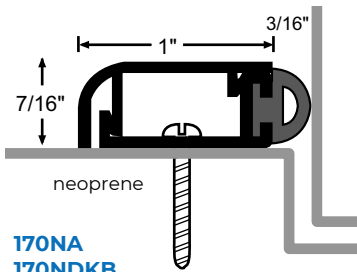

170NA
170NDKB

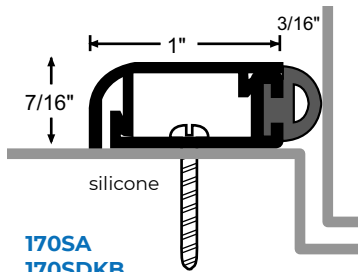

170SA
170SDKB



SUFFIX	FINISH
A	Anodized Aluminum
DKB	Dark Bronze / Black Anodized
None	Mill Aluminum

*Pile is Gray
Vinyl, Neoprene &
Silicone are Black
Nylon Brush is Gray with Anodized
Alum and Black with DKB Metal.
-BB = Black Brush*

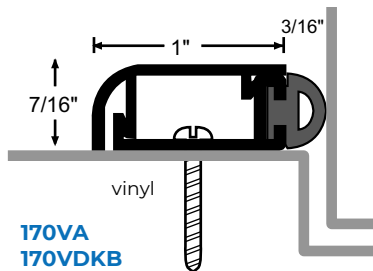

170VA
170VDKB

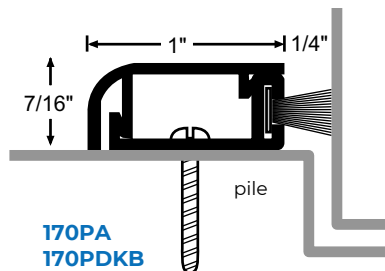

170PA
170PDKB

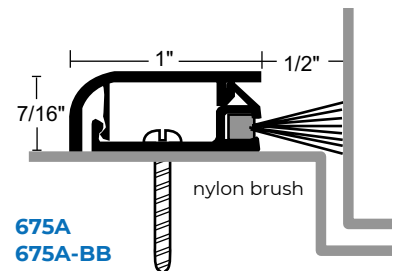

675A
675A-BB
675DKB

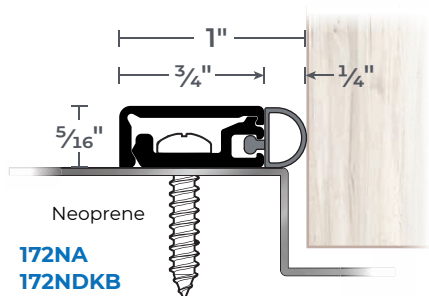

172NA
172NDKB

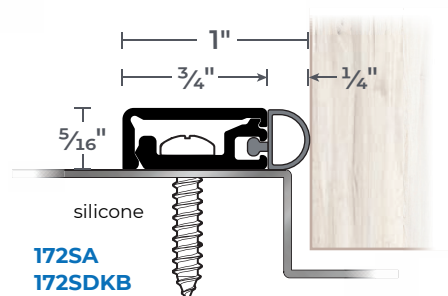

172SA
172SDKB

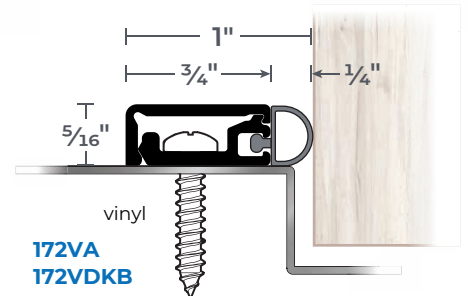

172VA
172VDKB

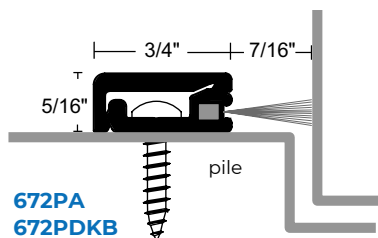

672PA
672PDKB

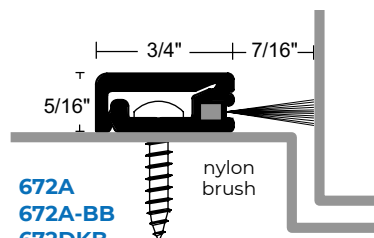

672A
672A-BB
672DKB



STAINLESS STEEL

- ▶ Stainless Steel Type 304 Brushed #4 Finish (US32D, 630)
- ▶ #6 x ¾" Stainless Steel SMS Furnished
- ▶ Screw Holes Slotted for Adjustment
- ▶ Microcellular EPDM, Silicone, Neoprene, Polyurethane are Black

127NSS
Stainless Steel Microcellular
EPDM Perimeter Seal

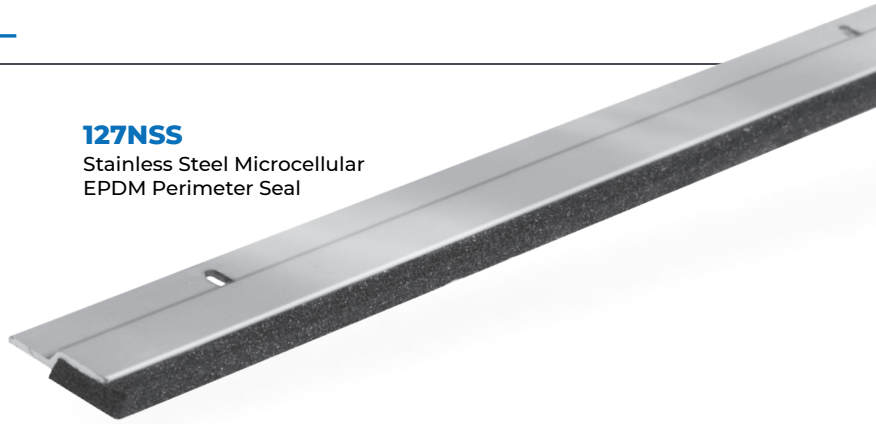

PERIMETER SEALS

120NSS Microcellular EPDM

120SSS Silicone

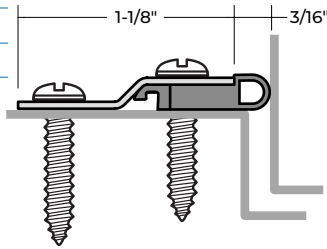

127NSS Microcellular EPDM

127SSS Silicone

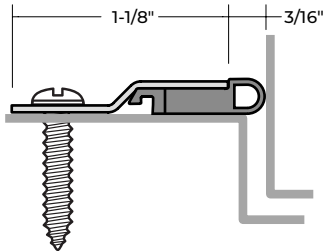

129NSS Neoprene

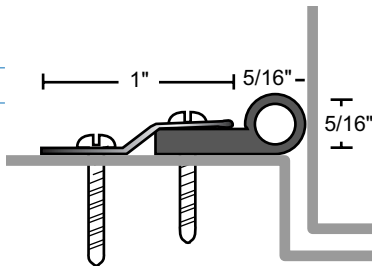

130NSS Microcellular EPDM

130SSS Silicone

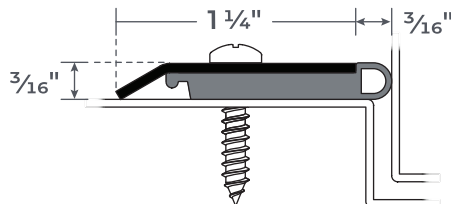

ASTRAGAL SEALS

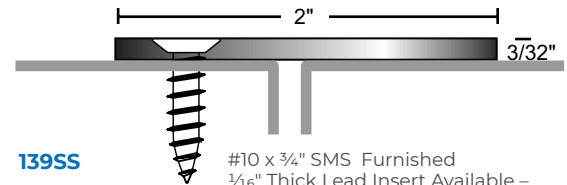

139SS

#10 x ¾" SMS Furnished
¼" Thick Lead Insert Available –
Specify "Lead-Lined"

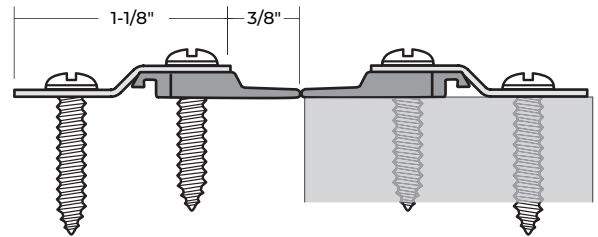

125NSS Microcellular EPDM

912SSS Silicone



Provided as Two-Piece Set

STAINLESS STEEL

- Stainless Steel Type 304 Brushed #4 Finish (US32D, 630)
- Silicone and Neoprene are Black. Nylon Brush Available in Gray or Black (Please Specify).
- #6 x 3/4" Stainless Steel SMS Furnished
- Screw Holes Slotted for Adjustment

RAIN DRIP GUARD

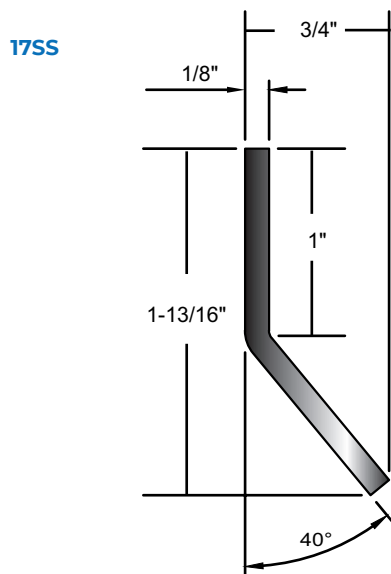
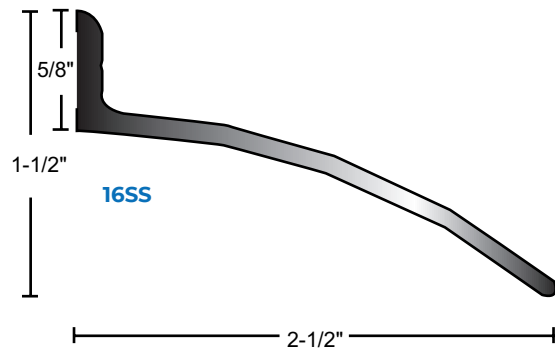

AUTOMATIC DOOR BOTTOM

- Stainless Steel Type 304 Brushed #4 Finish (US32D, 630)
- BHMA Certified to ANSI/BHMA A156.22, 1,000,000 Cycle Test-Grade 1
- Lead Insert Available for Radiation Shield – Specify ‘Lead Lined’
- Door Bottom is Handed. Right Hand Supplied Unless Specified

- 229NSS** Black Neoprene
- 229SSS** Black Silicone
- 229WHSS** Black Nylon Brush

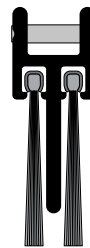

Drop Bar with Nylon Brush - Suffix "WH"

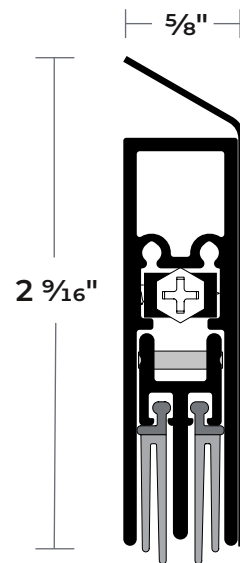

DOOR SWEEP

- 200NSS** Neoprene
- 200SSS** Silicone

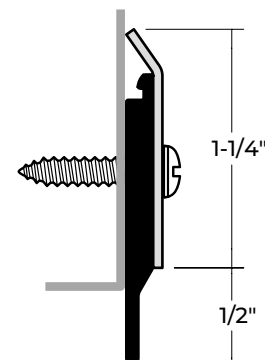

ADJUSTABLE PERIMETER SEALS

- ▶ Adjustment Screws on 10" Centers Allow Adjustment Without Re-Positioning Mounting Location
- ▶ #6 x 3/4" or #6 x 1 1/2" Stainless Steel SMS Furnished

107SA
Anodized Aluminum Adjustable Perimeter Seal with Silicone Seal

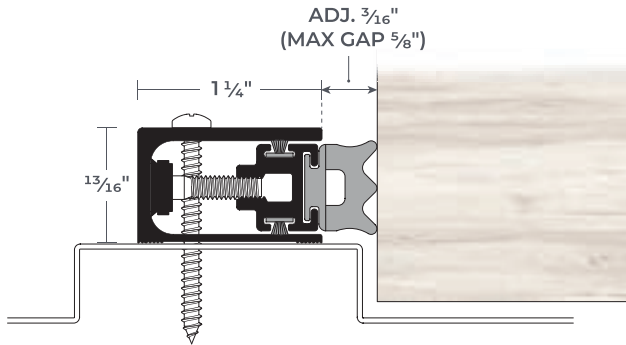

PRODUCT#	INSERT	FINISH
103NA	Black Neoprene	Anodized Aluminum
103NDKB	Black Neoprene	Dark Bronze / Black Anodized



Option: Foam back seal - suffix 'FS'
103N used with Parallel Arm Door Closer requires use of #3 Bracket on page G31

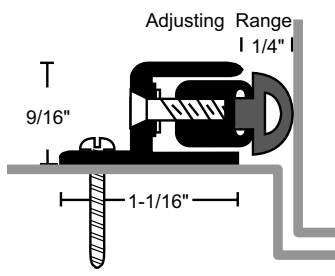

PRODUCT#	INSERT	FINISH
106NA	Black Neoprene	Anodized Aluminum
106NDKB	Black Neoprene	Dark Bronze / Black Anodized



PRODUCT#	INSERT	FINISH
106SA	Black Silicone	Anodized Aluminum
106SDKB	Black Silicone	Dark Bronze / Black Anodized



PRODUCT#	INSERT	FINISH
1038NA	Black Neoprene	Anodized Aluminum
1038NDKB	Black Neoprene	Dark Bronze / Black Anodized

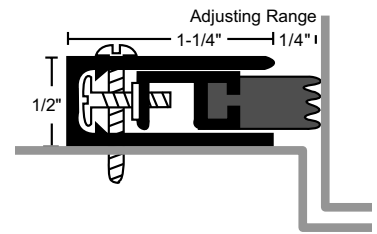

PRODUCT#	INSERT	FINISH
107NA	Black Neoprene	Anodized Aluminum
107NDKB	Black Neoprene	Dark Bronze / Black Anodized



PRODUCT#	INSERT	FINISH
107SA	Black Silicone	Anodized Aluminum
107SDKB	Black Silicone	Dark Bronze / Black Anodized



107 used with Parallel Arm Door Closer requires use of #7 Bracket on page G31

STEEL MOUNTING BRACKETS

All Products on This Page:



- Allows Installation of Door Closer Shoe or Rim Exit Device Strike Without Interruption or Notching of Perimeter Seals
- Furnished With #12 x 1 1/4" SMS
- 3/16" Thick Steel
- 6" Long
- Powder Coat Finish

3ASL	Aluminum Silver
3DKB	Matte Black
3SP	Prime Coat

Fits Over 103N, 1038N

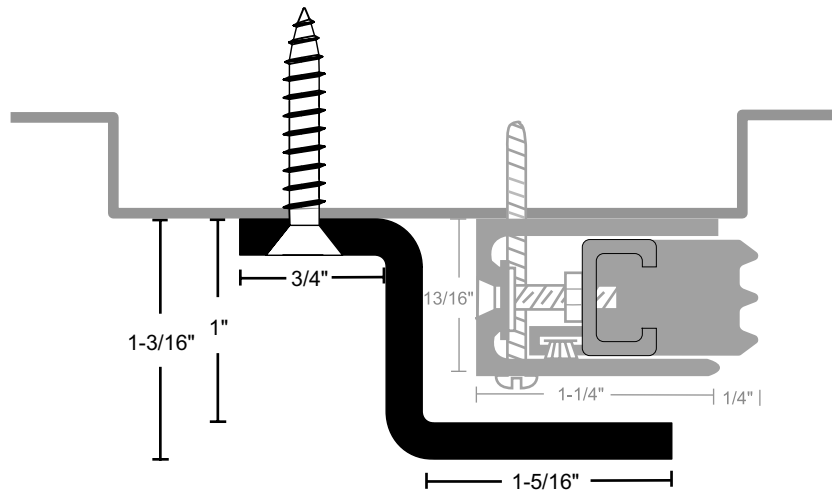

7ASL	Aluminum Silver
7DKB	Matte Black
7SP	Prime Coat

Fits Over 106N, 107N

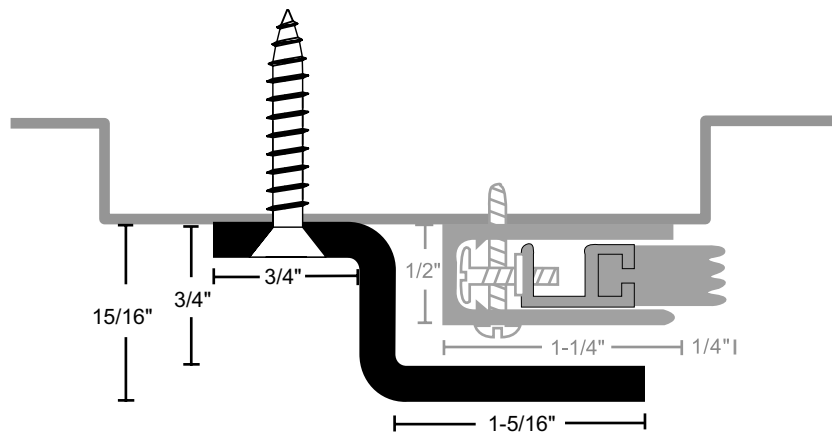

AUTOMATIC DOOR BOTTOMS

SURFACE

All Products on This Page:



- Mounts on Push Side of Door
- Use with a Threshold for Maximum Sealing Capability
- Nylon Brush Recommended for Carpet Applications Where No Threshold is Provided
- Specify Exact Net Length Required to Avoid Field Sizing
- ADB's from 12" to 18" Can be Cut Down 1/2". ADB's 20" and Over Can be Cut Down up to 1 1/2"
- Minimum Length 11 1/2", Maximum Length 60"
- 3/4" Max Drop
- Steel End Caps Furnished Standard – Black Finish
- BHMA Certified to ANSI/BHMA A156.22, 1,000,000 Cycle Test-Grade 1
- Lead Insert Available for Radiation Shield – Specify 'Lead Lined'
- All Automatic Door Bottoms are Handed. Right Hand Supplied Unless Specified. Field Reversible

220SA

Anodized Aluminum Automatic Door Bottom with Silicone Seal



PRODUCT#	SUFFIX	FINISH
	A	Anodized Aluminum
	DKB	Dark Bronze / Black Anodized
	None	Mill Aluminum

SURFACE

220NA	Black Neoprene
220NDKB	Black Neoprene
220SA	Black Silicone
220SDKB	Black Silicone

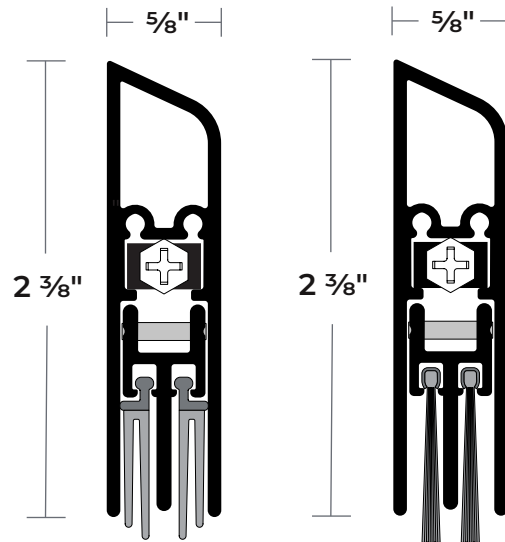

220WHA	Black Nylon Brush
220WHDKB	Black Nylon Brush

222NA	Black Neoprene
222NDKB	Black Neoprene
222SA	Black Silicone
222SDKB	Black Silicone
222WHA	Black Nylon Brush
222WHDKB	Black Nylon Brush

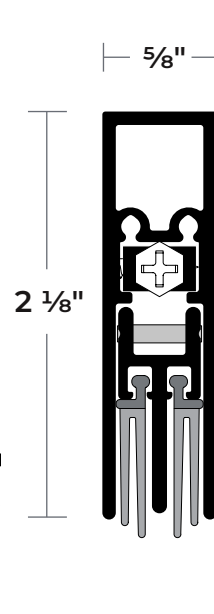

STAINLESS STEEL

- ADB's from 12" to 18" can be cut down 1/2". ADB's 20" and over can be cut down up to 1 1/2"
- Minimum Length 11 1/2", Maximum Length 60"
- 3/4" Max Drop
- Stainless Steel End Caps Furnished Standard – #4 Brushed Finish

229NSS	Black Neoprene
229SSS	Black Silicone
229WHSS	Black Nylon Brush

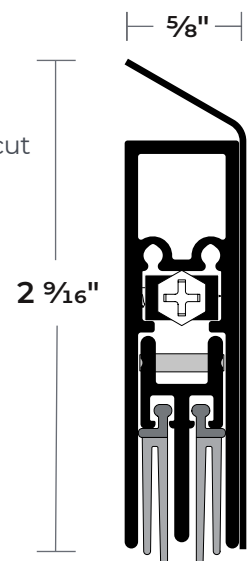

AUTOMATIC DOOR BOTTOMS

HEAVY-DUTY SURFACE

All Products on This Page:



- Mounts on Push Side of Door
- Use With a Threshold for Maximum Sealing Capability
- Nylon Brush Recommended for Carpet Applications Where No Threshold is Provided
- Specify Exact Net Length Required to Avoid Field Sizing
- ADB's from 12" to 18" Can be Cut Down 1/2".
ADB's 20" and Over Can be Cut Down up to 1 1/2"
- Minimum Length 11 1/2", Maximum Length 60"
- 3/4" Max Drop
- Steel End Caps Furnished Standard – Black Finish
- BHMA Certified to ANSI/BHMA A156.22, 1,000,000 Cycle Test-Grade 1
- Lead Insert Available for Radiation Shield – Specify 'Lead Lined'
- All Automatic Door Bottoms are Handed. Right Hand Supplied Unless Specified. Field Reversible

420NA

Anodized Aluminum Heavy-Duty Surface, Automatic Door Bottom with Neoprene Seal



PRODUCT# SUFFIX	FINISH
A	Anodized Aluminum
DKB	Dark Bronze / Black Anodized

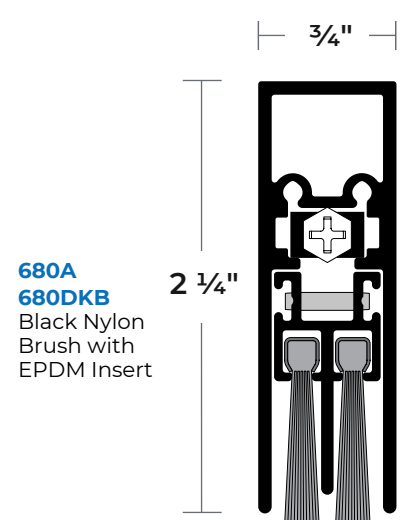
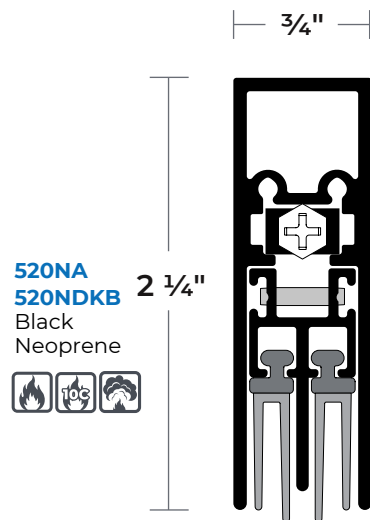
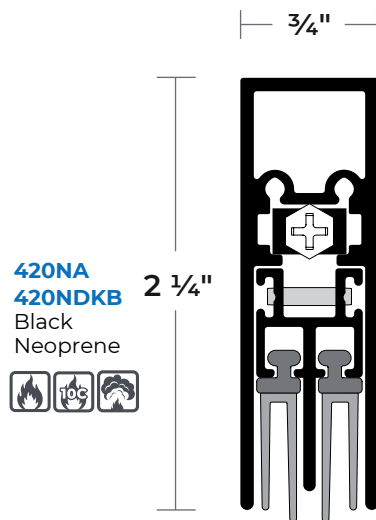
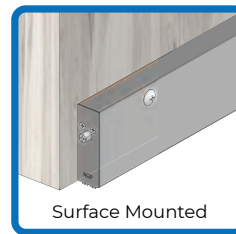

AUTOMATIC DOOR BOTTOMS

MORTISE

All Products on This Page:



- ▶ Fits Wood Fire Door Mortise Restrictions
- ▶ Use With a Threshold for Maximum Sealing Capability
- ▶ Nylon Brush Recommended for Carpet Applications Where No Threshold is Provided
- ▶ Specify Exact Net Length Required to Avoid Field Sizing
- ▶ Furnished 1/2" Shorter Than Ordered to Fit Within Net Door Size (i.e. 36" is Furnished 35 1/2")
- ▶ ADB's from 12" to 18" Can be Cut Down 1/2". ADB's 20" and Over Can be Cut Down up to 1 1/2"
- ▶ Minimum Length 11 1/2", Maximum Length 60"
- ▶ 3/4" Max Drop
- ▶ Black Plastic End Caps Furnished Standard
- ▶ BHMA Certified to ANSI/BHMA A156.22, 1,000,000 Cycle Test-Grade 1
- ▶ Lead Insert Available for Radiation Shield – Specify 'Lead Lined'
- ▶ Non-Handed

335NA

Clear Anodized Aluminum
Mortise Automatic Door
Bottom with Neoprene Seal



335NA Neoprene

Mortise Required
5/8" x 1 1/2"

335SA Silicone

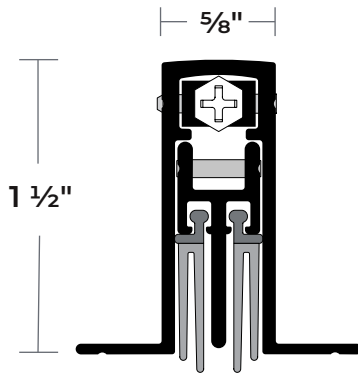

225NA Neoprene

Mortise Required
5/8" x 1 1/2"

225SA Silicone

225WHA
Nylon Brush

Drop Bar
with Nylon
Brush -
Suffix "WH"

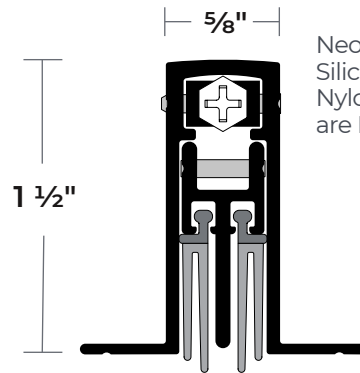

Neoprene,
Silicone &
Nylon Brush
are Black

HOLLOW METAL DOORS

- ▶ Fits in 1 5/8" x 3/4" Channel. A "Furring Strip" May Be Used to Lower Automatic Door Bottom When a Deeper Channel is Used
- ▶ Furnished 1/2" Shorter Than Ordered to Fit Within Net Door Size (i.e. 36" is Furnished 35 1/2") Length May Be Field Cut up to 1 1/2"
- ▶ 5/8" Max Drop
- ▶ Fire Ratings Apply to Metal Doors Only
- ▶ #6 x 1/2" Tek Screws Furnished
- ▶ End Caps Not Available
- ▶ Available 12" to 60" in Length
- ▶ BHMA Certified to ANSI/BHMA A156.22, 1,000,000 Cycle Test-Grade 1
- ▶ Lead Insert Available for Radiation Shield – Specify 'Lead Lined'
- ▶ Non-Handed

320SA

Clear Anodized Aluminum
Automatic Door Bottom for
Hollow Metal Doors with
Silicone Seal



320NA Neoprene

320SA Silicone

320VA Vinyl

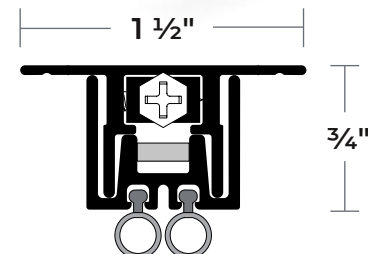

AUTOMATIC DOOR BOTTOMS

All Products on This Page:

HEAVY-DUTY MORTISE



- ▶ Fits Wood Fire Door Mortise Restrictions
- ▶ Use With a Threshold for Maximum Sealing Capability
- ▶ Nylon Brush Recommended for Carpet Applications Where No Threshold Is Provided
- ▶ Specify Exact Net Length Required to Avoid Field Sizing
- ▶ Furnished $\frac{1}{2}$ " Shorter Than Ordered to Fit Within Net Door Size (i.e. 36" is Furnished 35 $\frac{1}{2}$ ")
- ▶ ADB's from 12" to 18" Can be Cut Down $\frac{1}{2}$ ". ADB's 20" and Over Can be Cut Down up to 1 $\frac{1}{2}$ "
- ▶ Minimum Length 11 $\frac{1}{2}$ ", Maximum Length 60"
- ▶ $\frac{3}{4}$ " Max Drop
- ▶ Black Plastic End Caps Furnished Standard
- ▶ BHMA Certified to ANSI/BHMA A156.22, 1,000,000 Cycle Test-Grade 1
- ▶ Lead Insert Available for Radiation Shield – Specify 'Lead Lined' (Not Available on 423STC)
- ▶ Non-Handed

423NA

Anodized Aluminum Heavy-Duty Mortise Automatic Door Bottom with Neoprene Seal

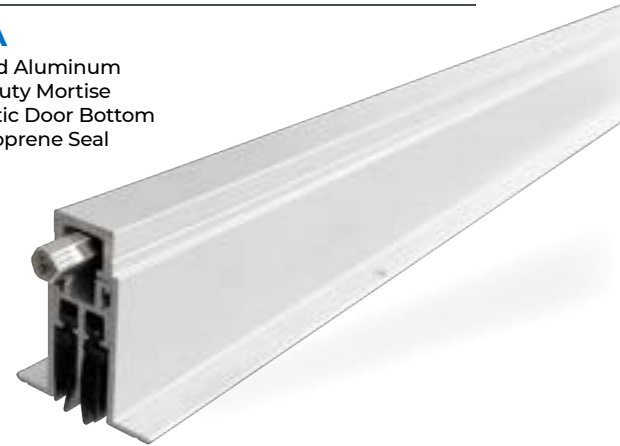

Neoprene is Black
Nylon Brush is Black
#6 x $\frac{1}{2}$ " Tek Screws
Furnished

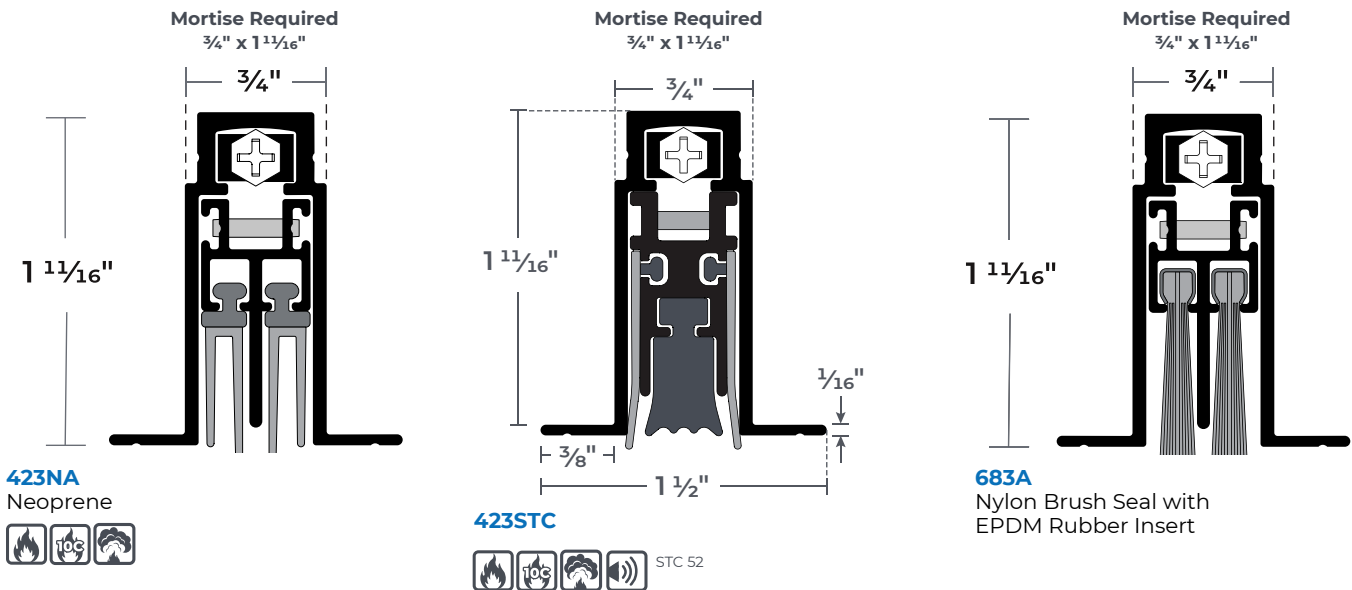

ACOUSTICAL DOOR SHOES

- ▶ Aluminum Alloy 6063, T5 Temper
- ▶ Thermoplastic Polymer: Polyvinyl Chloride
Formulated with an Environmentally Friendly Bio-Based Plasticizer
- ▶ Economical
- ▶ Flame-Resistant
- ▶ Moisture-Resistant
- ▶ Temperature Range 0°F to 140°F
- ▶ Oxidative Degradation From Age and Exposure to Cold, Heat and UV Causes Hardening, Loss of Memory and Resilience, Cracking, Crizzling and Discoloration
- ▶ #6 x 3/4" Stainless Steel SMS Furnished
- ▶ Screw Holes Slotted for Adjustment

312V X 131N
312VDKB X 131N



STC 45

SPECIFY THE DESIRED INSERT, FINISH AND COLOR WHEN PLACING YOUR ORDER.

PRODUCT# SUFFIX	FINISH
DKB	Dark Bronze / Black Anodized
None	Mill Aluminum

Vinyl is Black

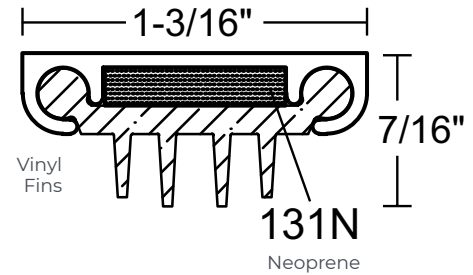

STC RATED ACOUSTICAL FOAM PAD

- ▶ Foam Seal Self-Adhesive
- ▶ Helps Acoustics and Seals at Corner Gap
- ▶ Apply to Jambs on Hinge and Strike Side
- ▶ Available as Set of 2 Pads
- ▶ Color is Black

60FP  STC 52

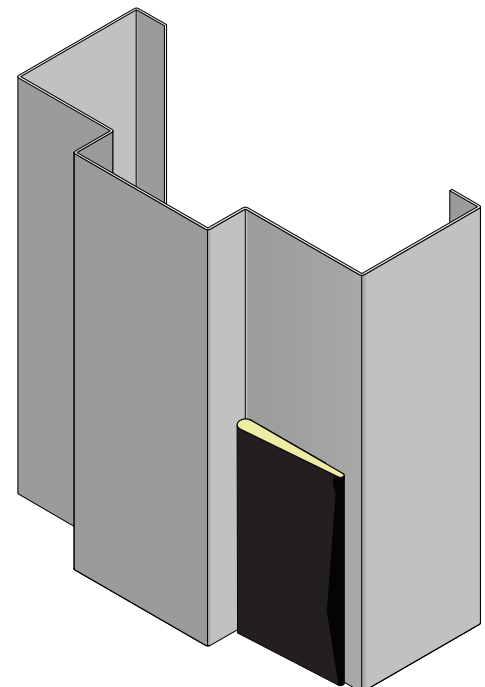
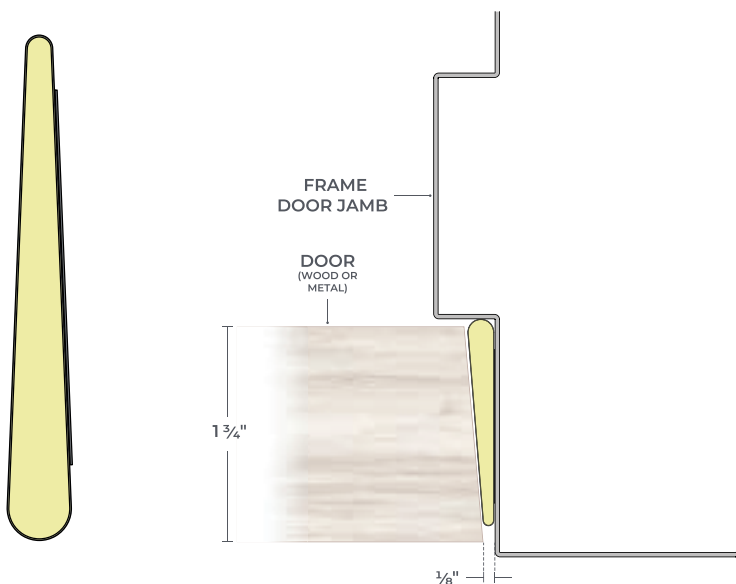

EXTENDED DOOR SHOES

All Products on This Page:



- ▶ #6 x 3/4" Stainless Steel
SMS Furnished
- ▶ End Caps Available -
Sold Separately

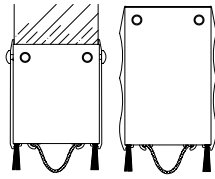

PRODUCT#	SUFFIX	FINISH
	A	Anodized Aluminum
	DKB	Dark Bronze / Black Anodized
	None	Mill Aluminum

*Vinyl is Black
Neoprene is Black
Thermoplastic is Dark Brown
Nylon Brush is Gray* with Anodized
Aluminum; Black with DKB Metal*

92 SERIES

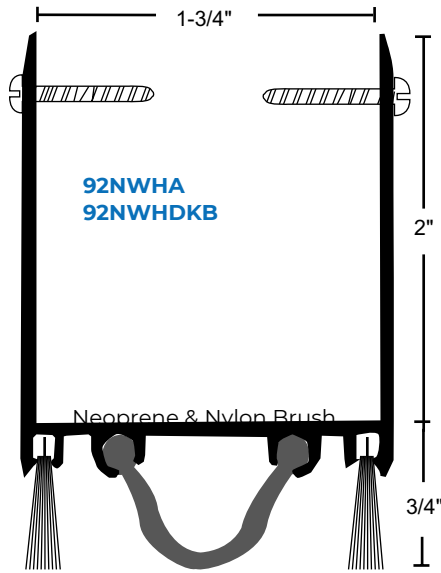

GASKETING OPTIONS:

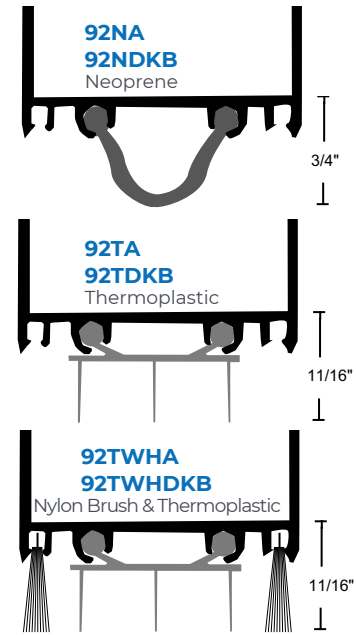
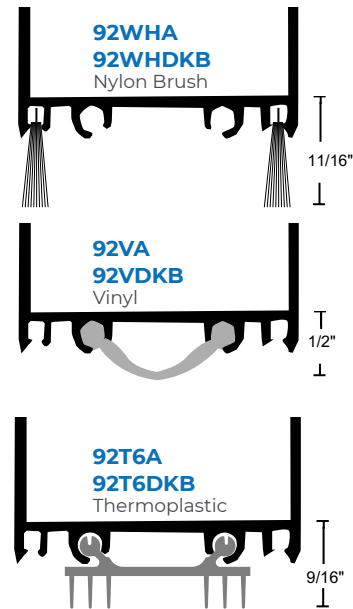

*Specify Black Brush if Desired

99 SERIES

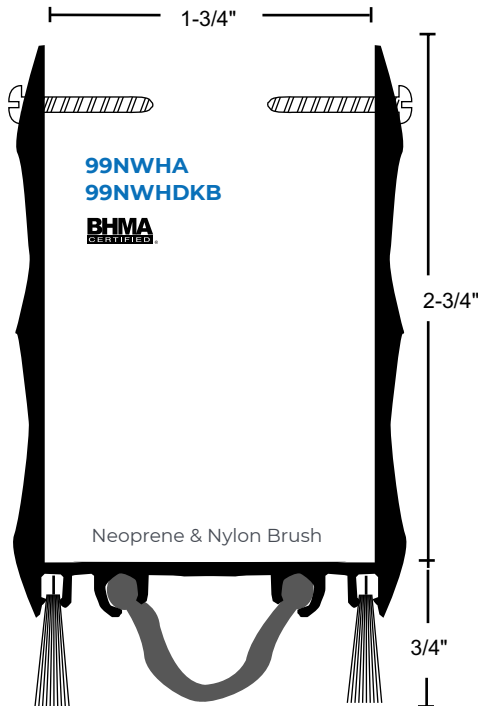

GASKETING OPTIONS:

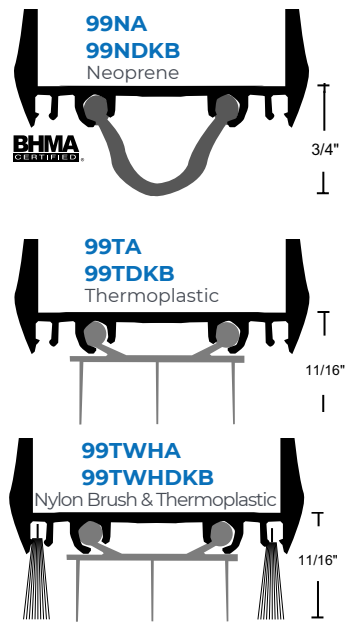
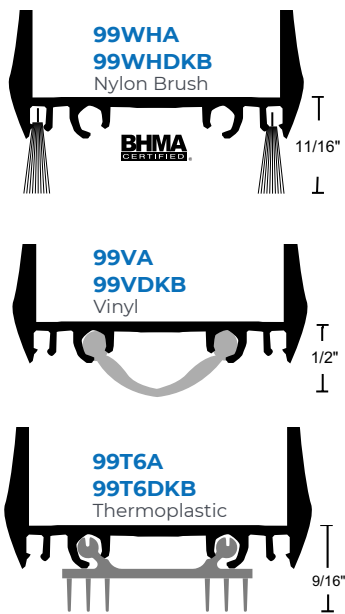

SMOOTH VINYL DOOR SHOES

- ▶ #6 x 3/4" Stainless Steel Sheet Metal Screws Furnished
- ▶ Screw Holes Slotted for Adjustment



PRODUCT#	SUFFIX	FINISH
	A	Anodized Aluminum
	DKB	Dark Bronze / Black Anodized
	None	Mill Aluminum
<i>Vinyl is Black</i>		

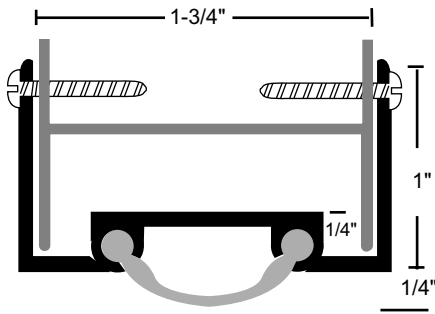

5VA
5VDKB

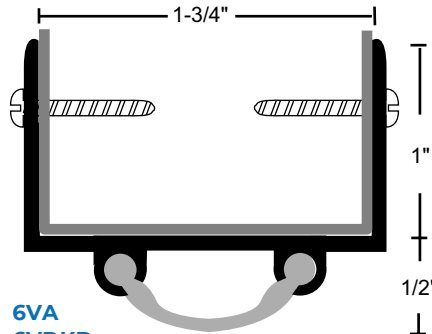

6VA
6VDKB

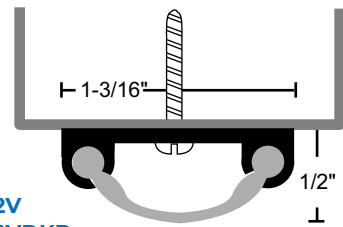

12V
12VDKB

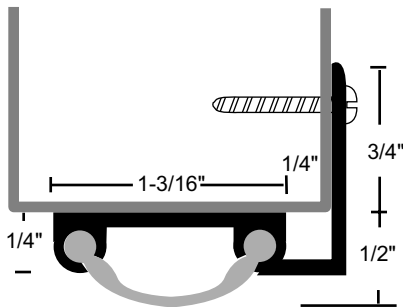

13VA
13VDKB

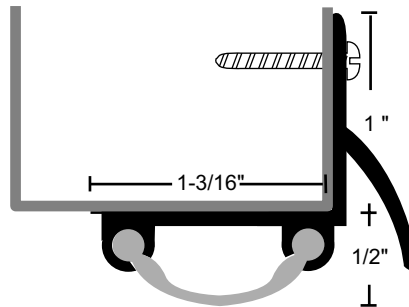

18V

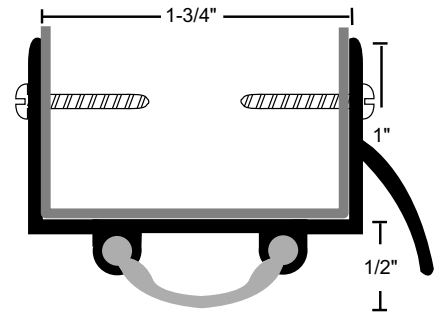

19V
19VDKB

POLYPROPYLENE PILE DOOR SHOES

- ▶ #6 x 3/4" Stainless Steel SMS Furnished
- ▶ Pile is Gray

254P
254PDKB

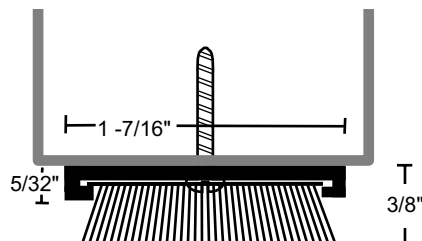

NEOPRENE, NYLON BRUSH, DOUBLE FIN

DOOR SHOES

NEOPRENE DOOR SHOES

- ▶ #6 x 3/4" Stainless Steel Sheet Metal Screws Furnished
- ▶ Screw Holes Slotted for Adjustment



PRODUCT# SUFFIX	FINISH
A	Anodized Aluminum
DKB	Dark Bronze / Black Anodized
None	Mill Aluminum

Neoprene is Black

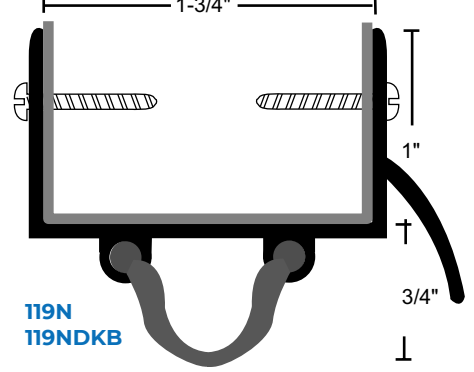
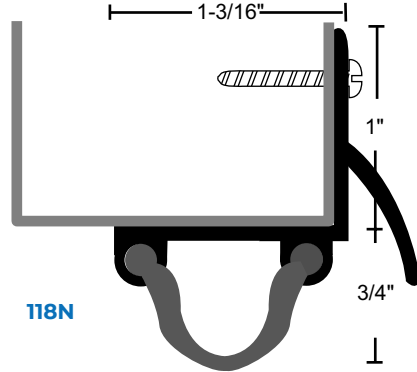
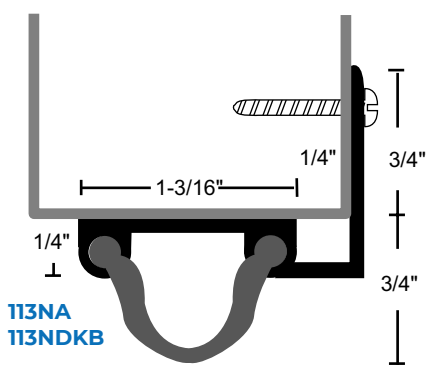
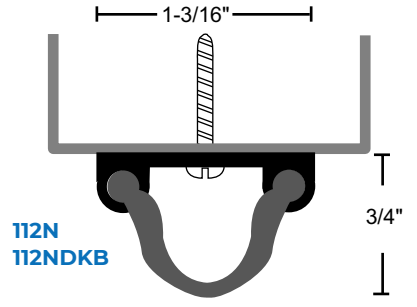
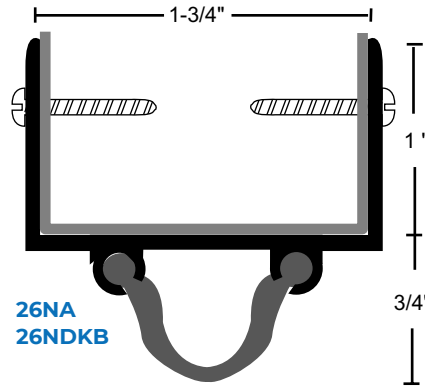
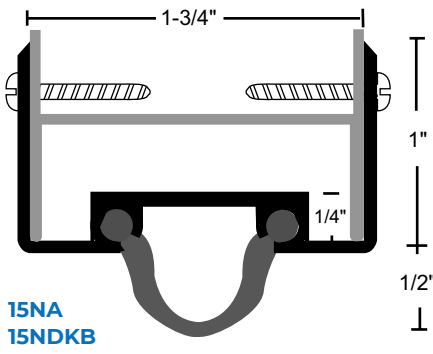

NYLON BRUSH DOOR SHOE

- ▶ #6 x 3/4" Stainless Steel SMS Furnished
- ▶ Screw Holes Slotted for Adjustment



95WH
Gray Brush

95WH-BB
Black Brush

95WHDKB
Black Brush

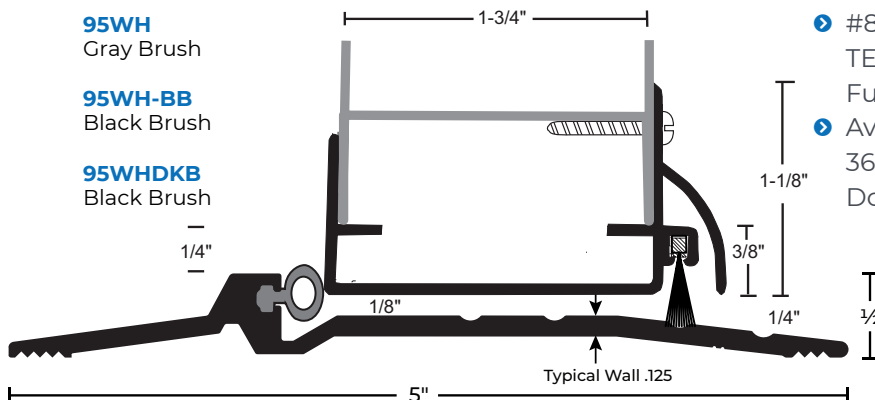

Designed for use on standard 3/4" undercut door used with NGP 896 V, N, or S ADA compliant threshold as shown

DOUBLE FIN DOOR SHOE

- ▶ Rigid Polypropylene Top with Flexible TPV Fins
- ▶ Designed for Hollow Metal Doors with Inverted Bottom Channel
- ▶ Furnished Undrilled
- ▶ #8 x 3/4" TEK Screws Furnished
- ▶ Available for 36" and 48" Door Widths

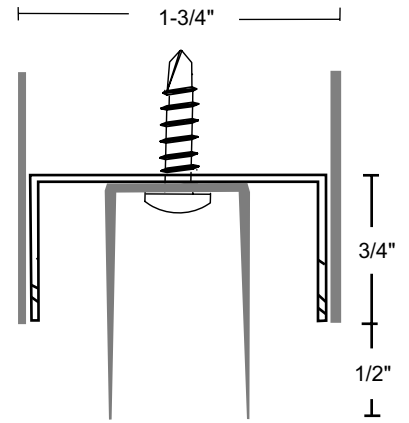

896
896DKB
Threshold

331
Black

FINNED VINYL DOOR SHOES

All Products on This Page:



- ▶ #6 x 3/4" Stainless Steel SMS Furnished
- ▶ Screw Holes Slotted for Adjustment

PRODUCT#	SUFFIX	FINISH
	A	Anodized Aluminum
	DKB	Dark Bronze / Black Anodized
	None	Mill Aluminum
<i>Vinyl is Black</i>		

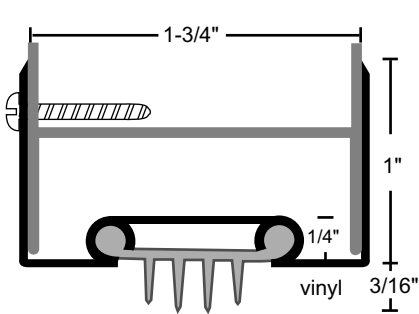

35EV
35EVDKB

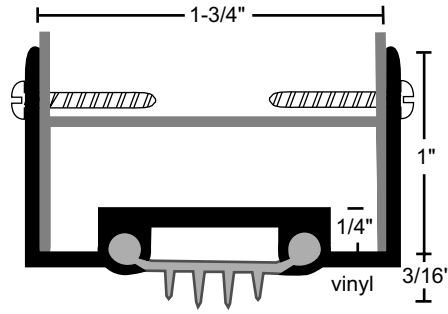

35VA
35VDKB

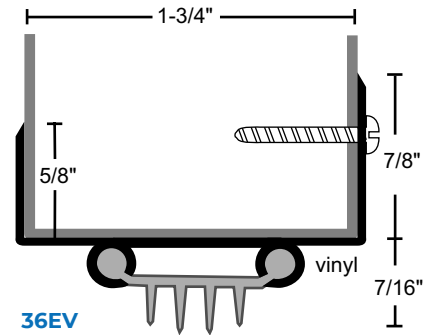

36EV
36EVDKB

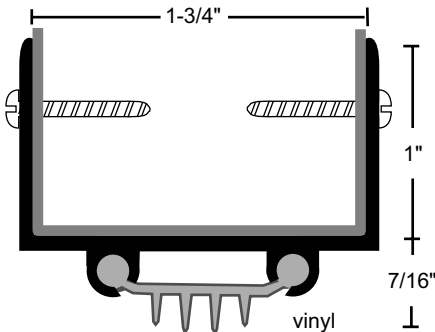

36VA
36VDKB

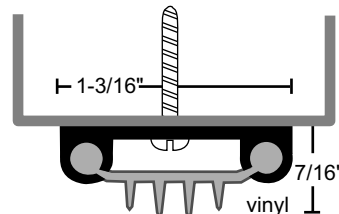

312V
312VDKB

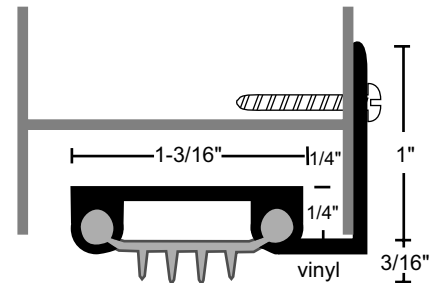

313VA
313VDKB

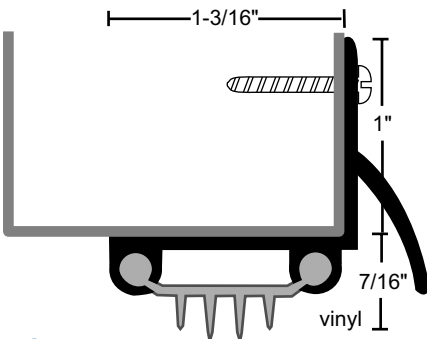

318V

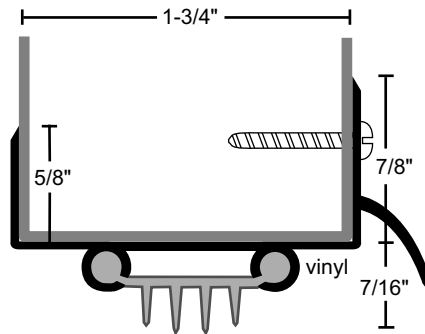

319EV
319EVDKB

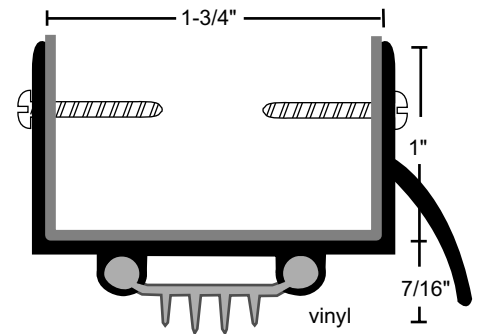

319V
319VDKB

THERMOPLASTIC DOOR SHOES

All Products on This Page:



- ▶ Thermoplastic Polymer Seal with Rigid Base and Soft Vinyl Fins
- ▶ 48" Maximum Length
- ▶ #6 x 3/4" Stainless Steel SMS Furnished

PRODUCT#	SUFFIX	FINISH
	A	Anodized Aluminum
	DKB	Dark Bronze / Black Anodized
	None	Mill Aluminum

Thermoplastic is Dark Brown

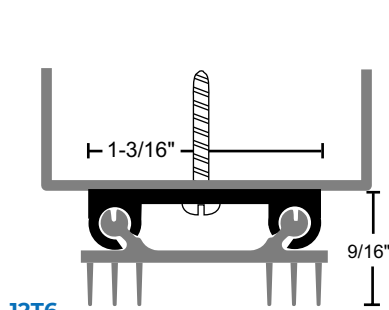

12T6
12T6DKB

STC 52
Requires STC-FH
option

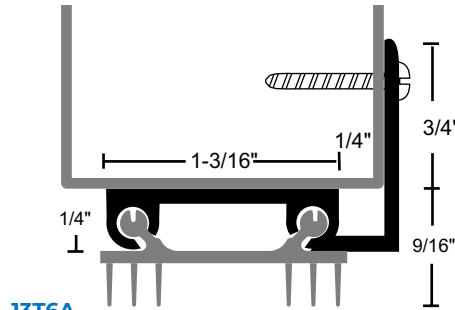

13T6A
13T6DKB

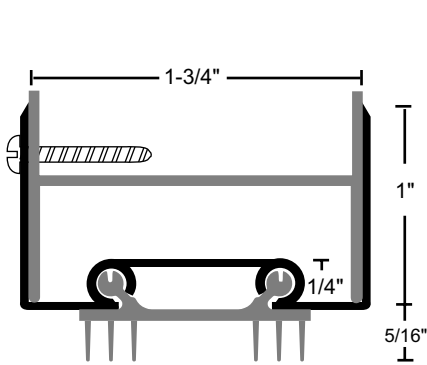

35ET6
35ET6DKB

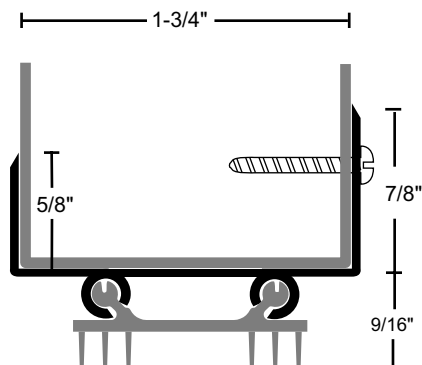

36ET6
36ET6DKB

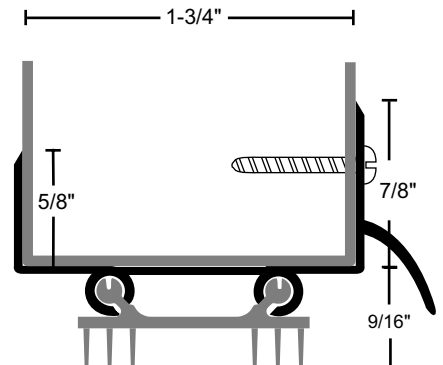

319ET6
319ET6DKB

EXTENDED DOOR SHOES

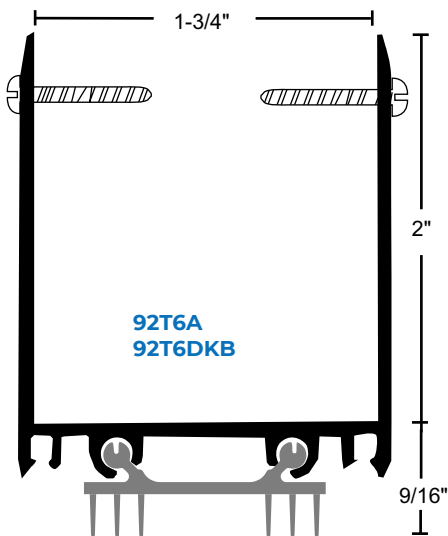

92T6A
92T6DKB

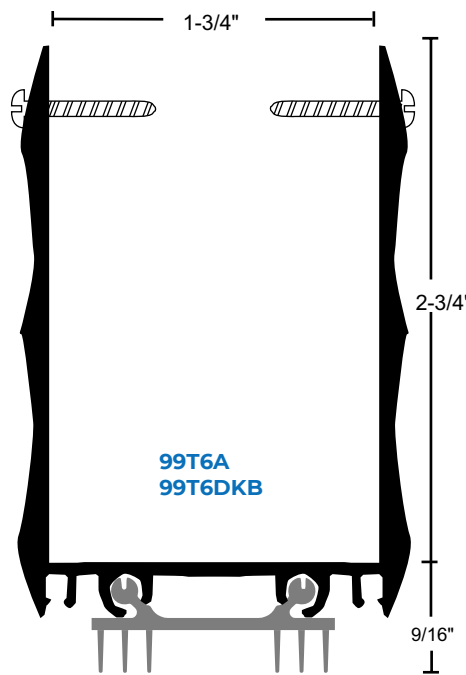

99T6A
99T6DKB

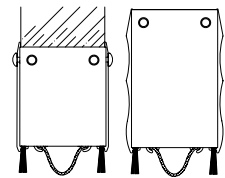

End Caps Available -
Sold Separately

THERMOPLASTIC DOOR SHOES

- ▶ Thermoplastic Polymer Seal with Rigid Base and Soft Vinyl Fins
- ▶ Available with Notched Fins to Allow Air Flow While Restricting Light, Suffix NF
- ▶ 48" Maximum Length
- ▶ #6 x 3/4" Stainless Steel SMS Furnished

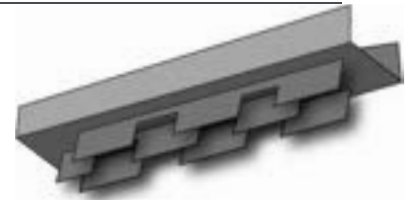

Option: Notched Fins - Suffix 'NF'

PRODUCT#	
SUFFIX	FINISH
A	Anodized Aluminum
DKB	Dark Bronze / Black Anodized
None	Mill Aluminum

Thermoplastic is Dark Brown

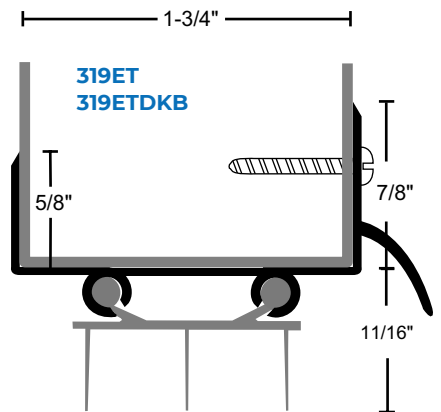
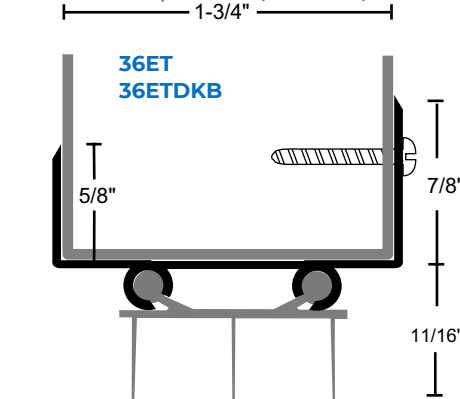
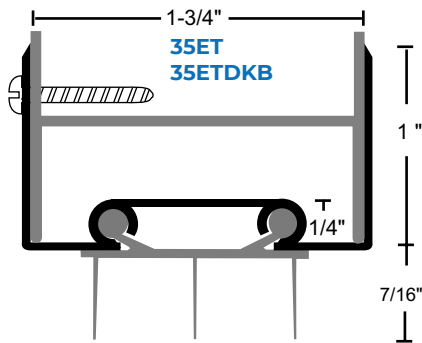
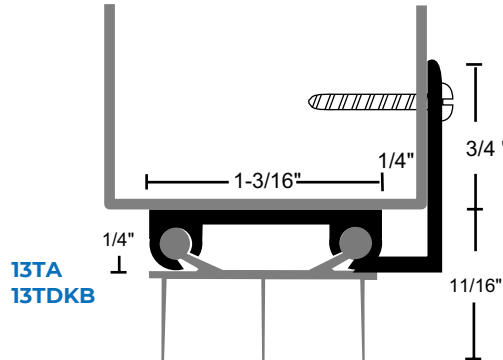
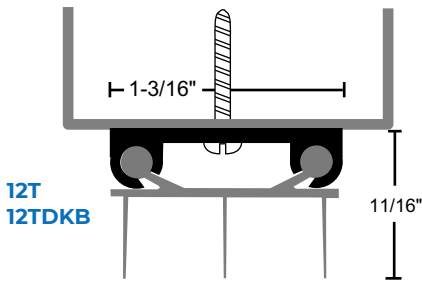

EXTENDED DOOR SHOES

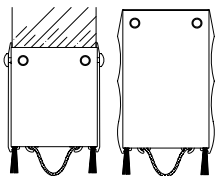

End Caps Available - Sold Separately

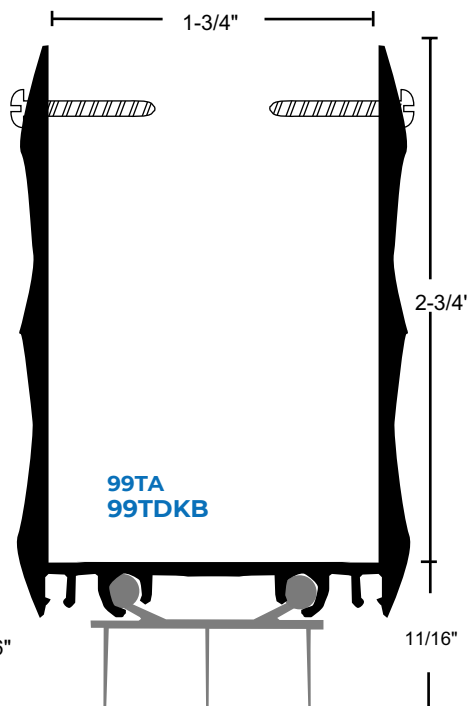
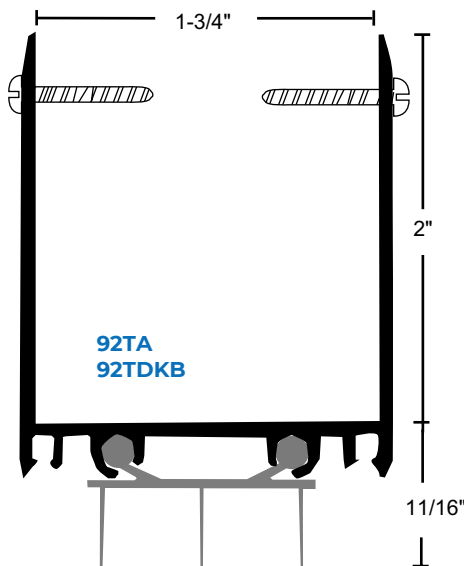

RIGID THERMOPLASTIC DOOR SHOE WITH SOFT VINYL FINIS

- ▶ Available 36" and 48"
- ▶ Color is Dark Brown

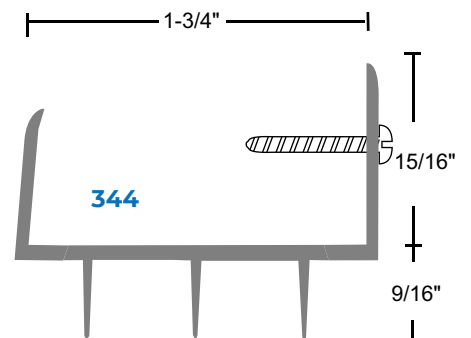

NEOPRENE AND SILICONE SWEEPS

NEOPRENE SWEEPS

- ▶ #6 x 3/4" Stainless Steel Sheet Metal Screws Furnished
- ▶ Screw Holes Slotted for Adjustment.



*except 203N

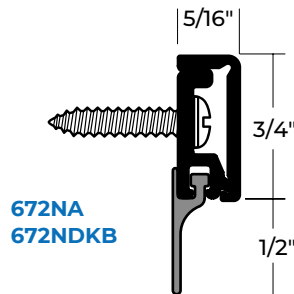
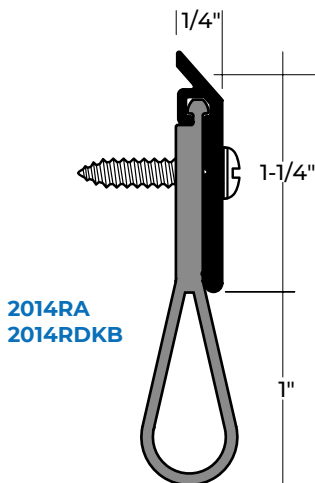
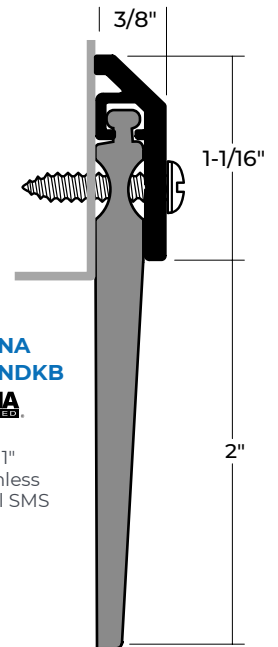
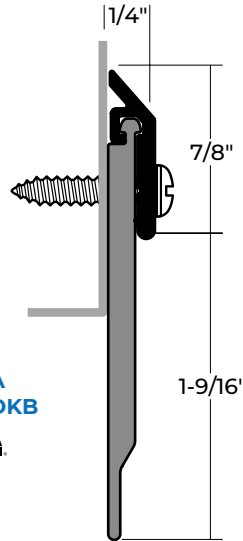
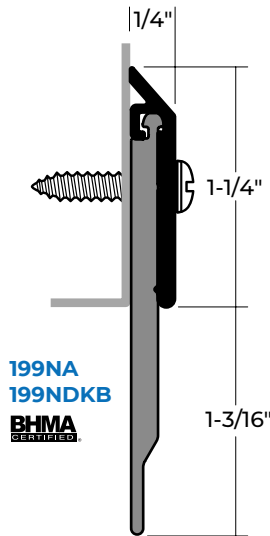
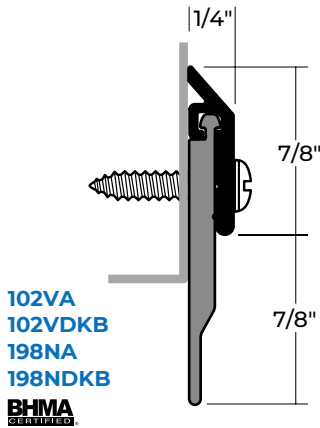
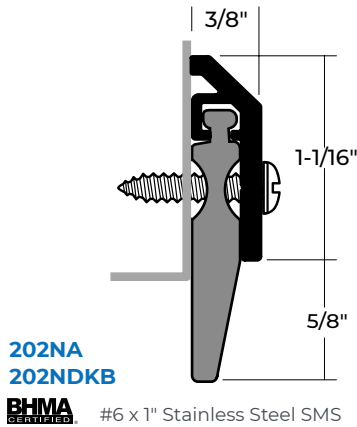
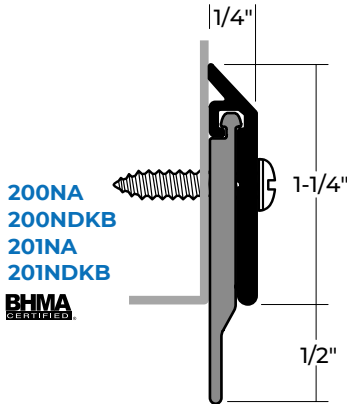

SILICONE SWEEP



200NA
 Anodized Aluminum
 Neoprene Door Sweep

PRODUCT#	SUFFIX	FINISH
	A	Anodized Aluminum
	DKB	Dark Bronze / Black Anodized
	None	Mill Aluminum

Neoprene and Silicone are Black

VINYL SWEEPS



- ▶ #6 x 3/4" Stainless Steel SMS Furnished
- ▶ Screw Holes Slotted for Adjustment
- ▶ Vinyl is Black

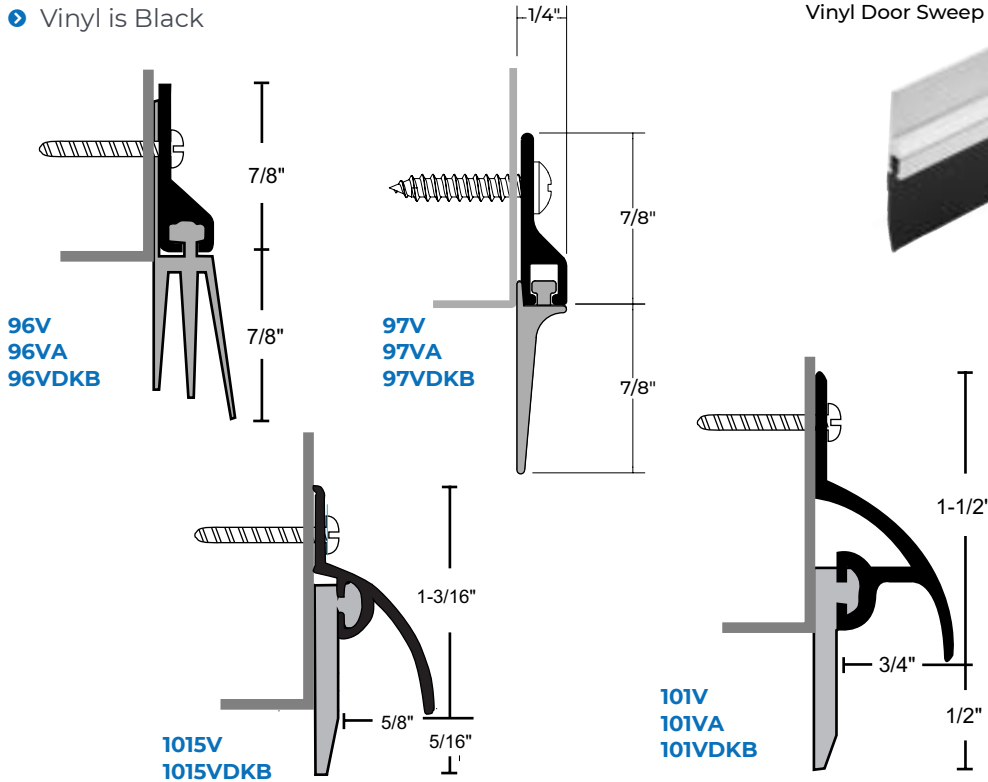

97VA
Anodized Aluminum
Vinyl Door Sweep

PRODUCT#	SUFFIX	FINISH
A		Anodized Aluminum
DKB		Dark Bronze / Black Anodized
None		Mill Aluminum

-BB = Black Brush

CONCEALED FASTENER NYLON BRUSH SWEEPS



- ▶ Gray Brush with Anodized Aluminum
- ▶ Black Brush with DKB
- BB = Black Brush*

672A
Anodized Aluminum
Concealed Fastener with
Nylon Brush Sweep

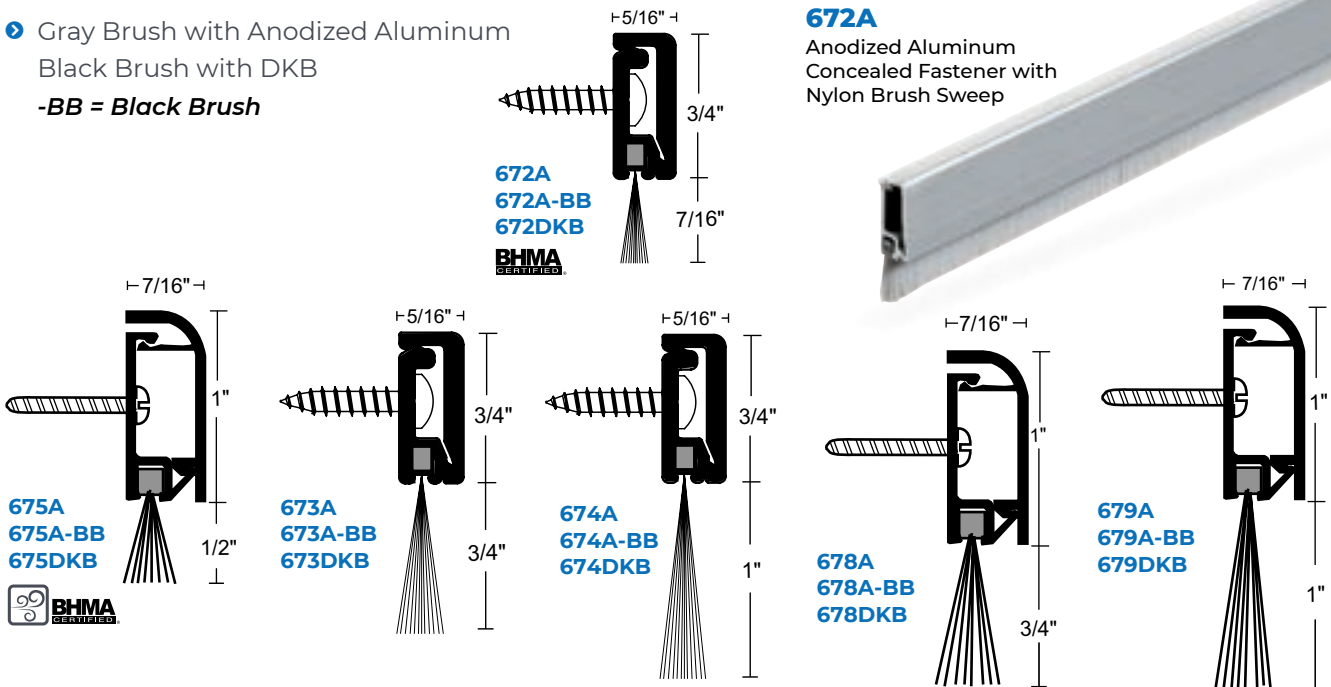

NYLON BRUSH SWEEPS

- ▶ #6 x 3/4" Stainless Steel SMS Furnished
- ▶ Screw Holes Slotted for Adjustment



PRODUCT#	FINISH
SUFFIX	
A	Anodized Aluminum with Gray Brush*
DKB	Dark Bronze / Black Anodized with Black Brush
None	Mill Aluminum with Gray Brush

-BB = Black Brush

600A
Anodized Aluminum
Nylon Brush Seal
or Sweep

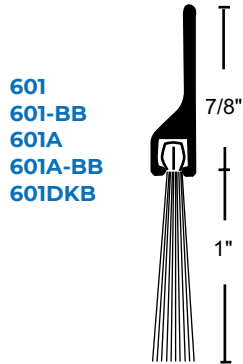
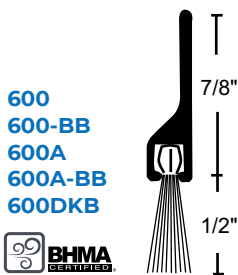
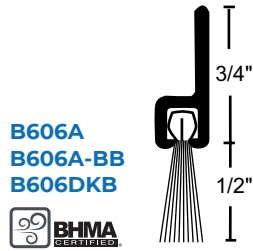
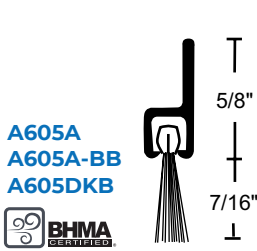

C627A
Anodized Aluminum
Nylon Brush Seal
or Sweep

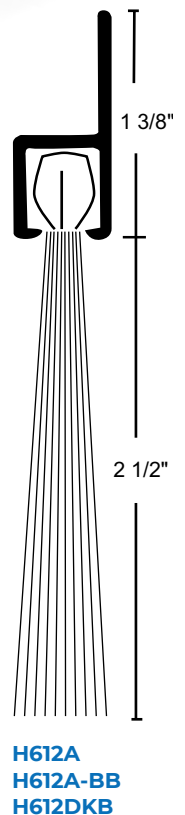
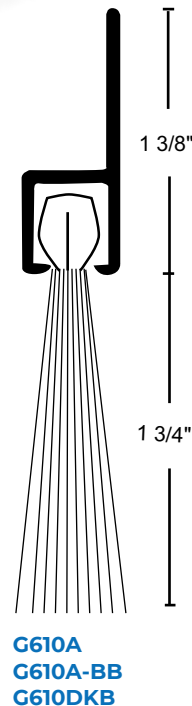
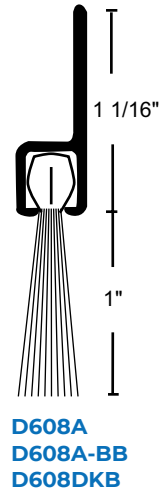
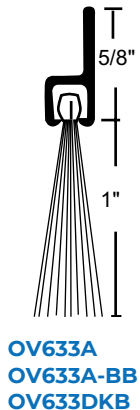
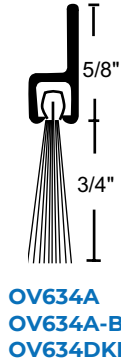
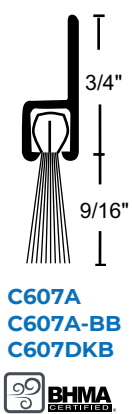
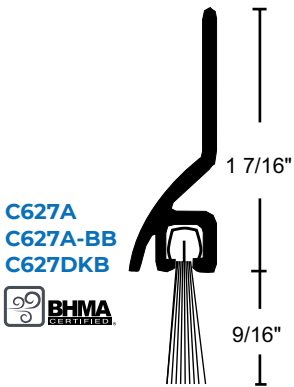

NYLON BRUSH SEALS WITH EPDM RUBBER INSERT

- EPDM Rubber Insert Protects Against Water Penetration and Provides an Effective Bottom Seal for Exterior Doors
- Excellent Abrasion Resistance, Flexibility and Memory
- Moisture-Resistant
- Retains Insecticides Well
- Temperature Range - 60°F to 300°F
- #6 x 3/4" Stainless Steel SMS Furnished
- Screw Holes Slotted for Adjustment

PRODUCT# SUFFIX	FINISH
A	Clear Anodized with Black Brush
DKB	Dark Bronze /Black Anodized with Black Brush

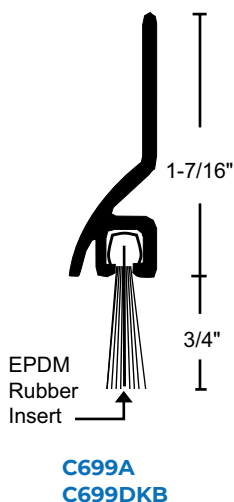
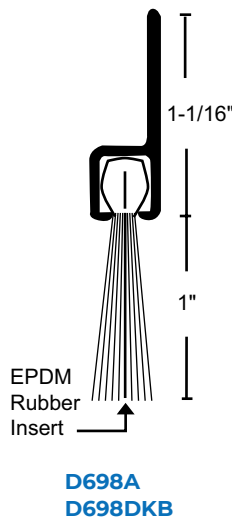
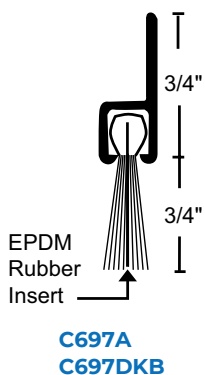

DOOR BOTTOM SEALS

- ▶ Synthetic EPDM Rubber in Polypropylene Thermoplastic Matrix
- ▶ Flame-Resistant
- ▶ Moisture-Resistant
- ▶ Good Resistance to Ozone, Sunlight and Aging

PRODUCT#	FINISH
SUFFIX	
A	Anodized Aluminum
DKB	Dark Bronze / Black Anodized
None	Mill Aluminum

Neoprene & Silicone are Black

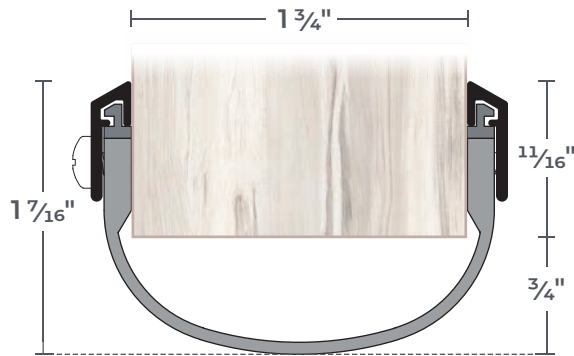

For 1 3/4" Doors: **14RA-1 3/4"**
14RDKB-1 3/4"

For 2 1/4" Doors: **14RA-2 1/4"**
14RDKB-2 1/4"

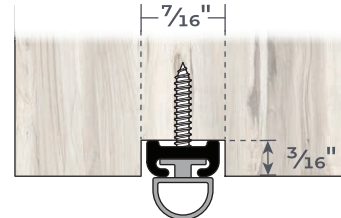

136N
136NDKB
Neoprene

136S
136SDKB
Silicone



Mortise 7/16" Wide x Desired Depth.
#2 SMS Furnished

OVERHEAD DOOR BOTTOM SEAL

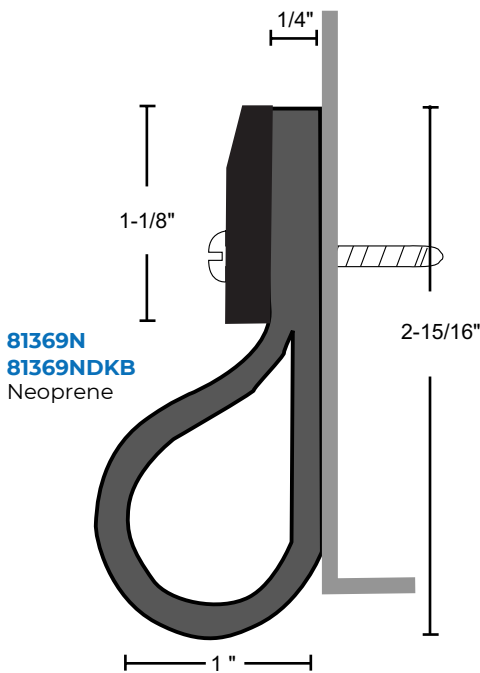

81369N
81369NDKB
Neoprene

#8 x 1-1/4" Stainless Steel SMS



81369N
Mill Aluminum
Overhead Door
Bottom Seal

- ▶ Synthetic EPDM Rubber in Polypropylene Thermoplastic Matrix
- ▶ Very Good Abrasion Resistance, Tensile Strength and Memory
- ▶ Flame-Resistant
- ▶ Moisture-Resistant
- ▶ Temperature Range -81°F to 275°F
- ▶ Good Resistance to Ozone Sunlight and Aging

SMOKE-RATED ASTRAGAL SEALS



- Fire-Rated Astragal Seals Cannot Replace any Astragal Required on the Door by the Door Manufacturer to Maintain its Fire Label. IBC, NFPA 80, NFPA105, and NFPA 252 Require the Gap at the Meeting Edge Between Fire Labeled Doors Must Not Exceed 1/8"
- #6 x 3/4" Stainless Steel Sheet Metal Screws Furnished
- Screw Holes Slotted for Adjustment

METAL	EPDM	NEOPRENE	SILICONE	NYLON+
A - Anodized Aluminum	Black	Black	Black	Gray
DKB - Dark Bronze / Black Anodized	Black	Black	Black	Black
No Suffix - Mill Aluminum	Black	Black	Black	Gray

-BB = Black Brush

- 5070B** Brown Self-Adhesive Silicone
- 5070CL** Clear Self-Adhesive Silicone

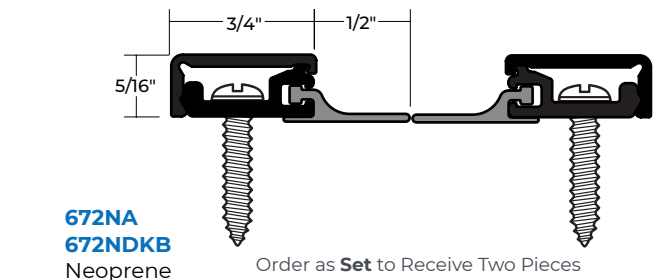
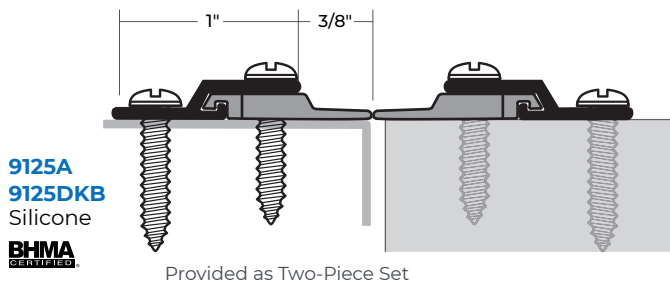
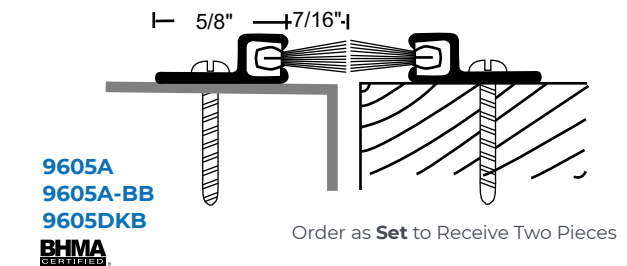
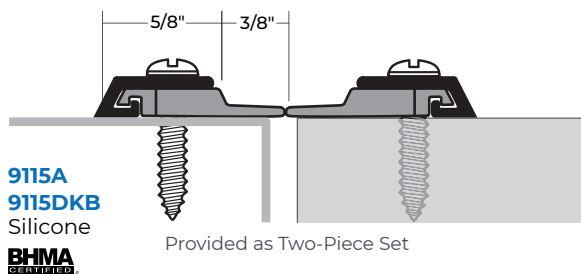
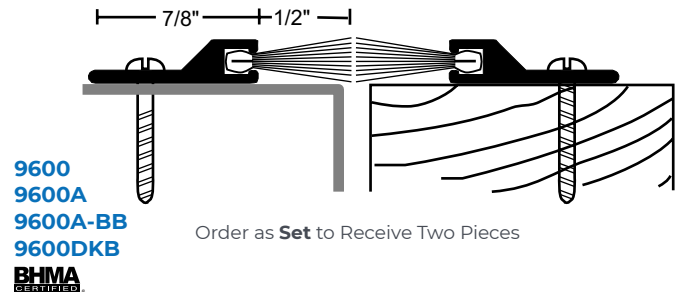
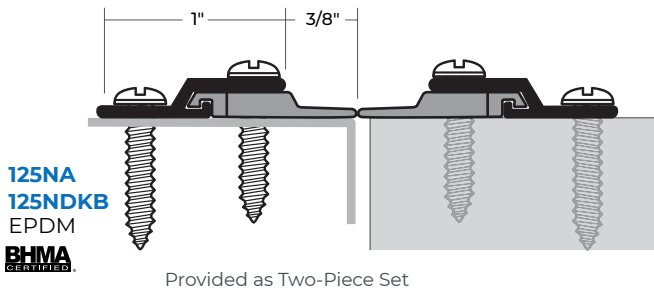
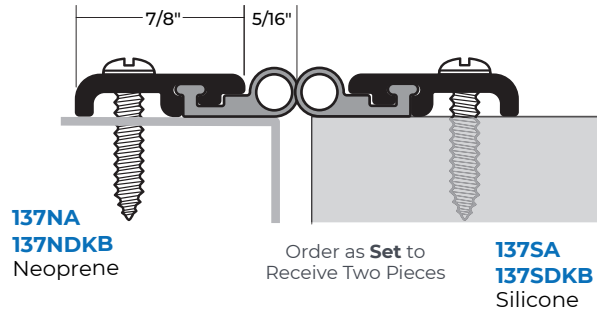
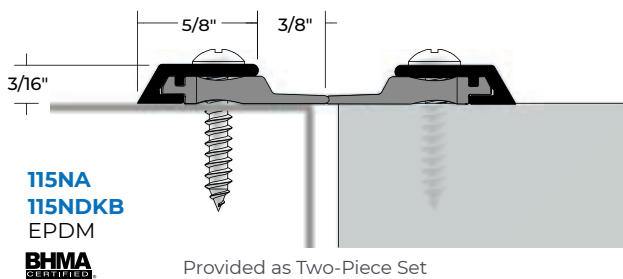
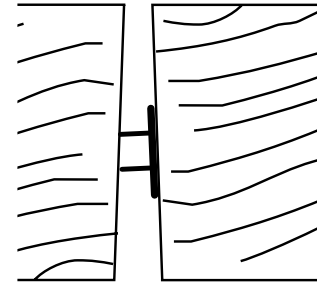

SURFACE MOUNTED ASTRAGAL SETS

- ▶ #6 x 3/4" Stainless Steel SMS Furnished
- ▶ Screw Holes are Slotted for Adjustment

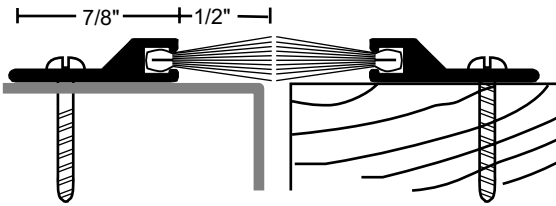

PRODUCT#	INSERT	FINISH
600	Gray Nylon Brush	Mill Al
600-BB	Black Nylon Brush	Mill Al
600A	Gray Nylon Brush	Anodized Al
600A-BB	Black Brush	Anodized Al
600DKB	Black Nylon Brush	Dark Bronze / Black Anodized

Order as **Set** to Receive Two Pieces

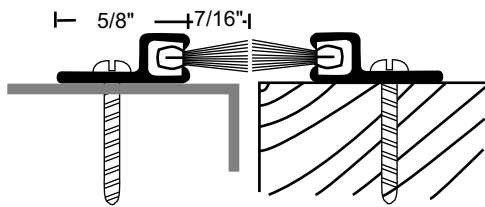

PRODUCT#	INSERT	FINISH
A605A	Gray Nylon Brush	Anodized Al
A605A-BB	Black Nylon Brush	Anodized Al
A605DKB	Black Nylon Brush	Dark Bronze / Black Anodized

Order as **Set** to Receive Two Pieces

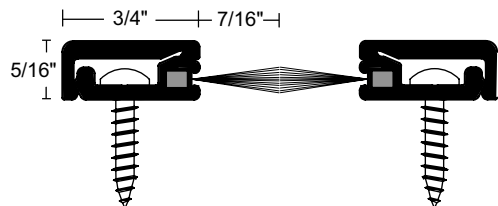

PRODUCT#	INSERT	FINISH
672A	Gray Nylon Brush	Anodized Al
672A-BB	Black Brush	Anodized Al
672DKB	Black Nylon Brush	Dark Bronze / Black Anodized

Order as **Set** to Receive Two Pieces

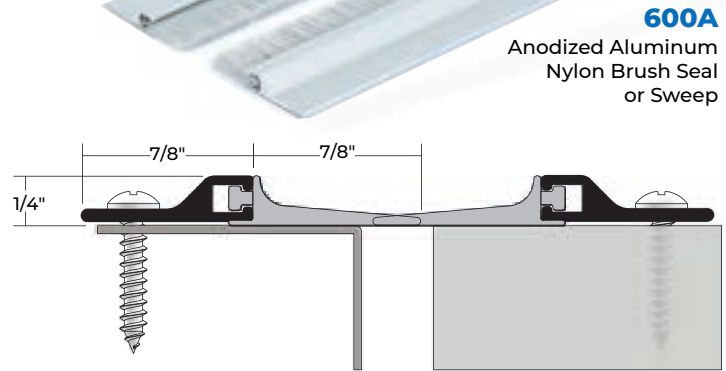

600A
Anodized Aluminum
Nylon Brush Seal
or Sweep

PRODUCT#	INSERT	FINISH
97V	Black Vinyl	Mill Al
97VA	Black Vinyl	Anodized Al
97VDKB	Black Vinyl	Dark Bronze / Black Anodized

Order as **Set** to Receive Two Pieces

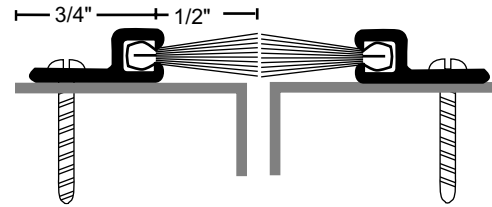

PRODUCT#	INSERT	FINISH
B606A	Gray Nylon Brush	Anodized Al
B606A-BB	Black Nylon Brush	Anodized Al
B606DKB	Black Nylon Brush	Dark Bronze / Black Anodized

Order as **Set** to Receive Two Pieces

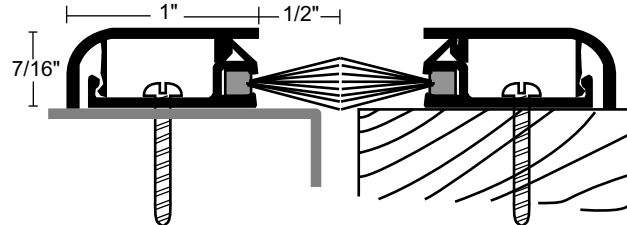

PRODUCT#	INSERT	FINISH
675A	Gray Nylon Brush	Anodized Al
675A-BB	Black Brush	Anodized Al
675DKB	Black Nylon Brush	Dark Bronze / Black Anodized

Order as **Set** to Receive Two Pieces

SPRING ADJUSTABLE ASTRAGAL SETS

- Adjustment Screws on 10" Centers Allow Adjustment of the Seal Without Re-Positioning Mounting Location
- Spring-Loaded to Maintain Constant Pressure for the Most Effective Seal



140PA
Anodized Aluminum
Spring Loaded Pile
Astragal

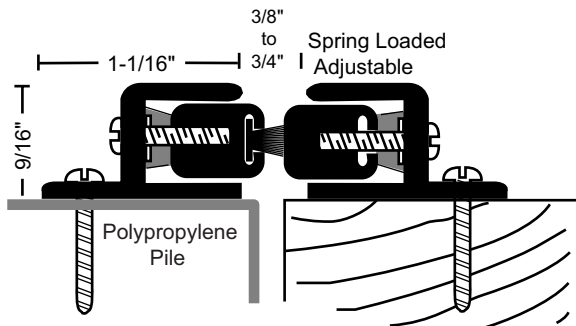

140PA
140PDKB
Pile is Gray

Provided as Two-Piece Set

PRODUCT# SUFFIX	FINISH
A	Anodized Aluminum
DKB	Dark Bronze / Black Anodized
None	Mill Aluminum

*Pile is Gray
Silicone is Black*

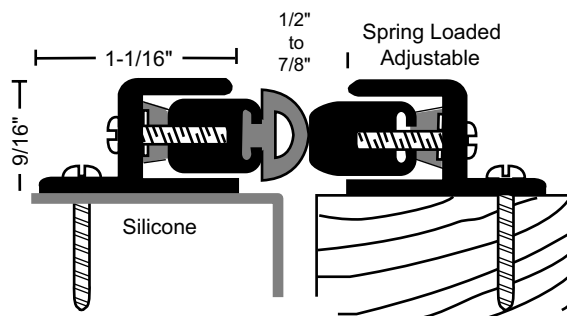

140SA
140SDKB
Silicone is Black



Provided as Two-Piece Set

MAGNETIC ASTRAGAL SETS

- #6 x 3/4" Stainless Steel SMS Furnished
- Screw Holes are Slotted for Adjustment
- Maximum Length 120"
- Not Recommended for Use on Metal Doors

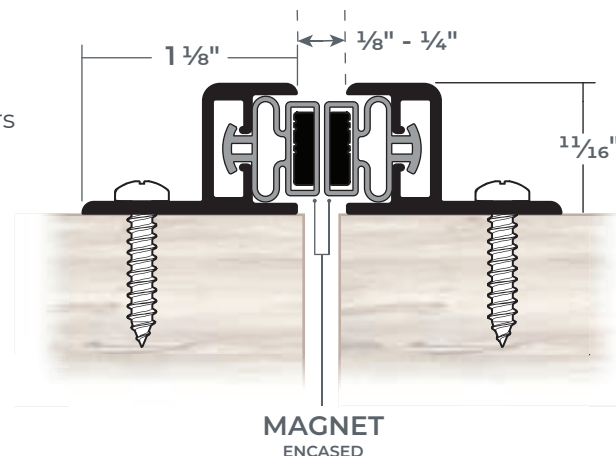

149MA
149MDKB

Provided as Two-Piece Set
Magnet Encased in Black Vinyl

OVERLAPPING ASTRAGALS

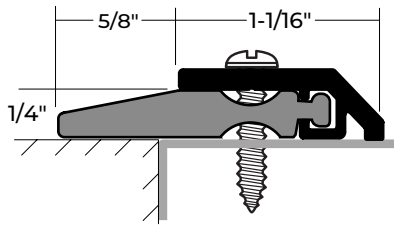

109NA
109NDKB
Neoprene
#6 x 1" & #6 x 3/4"
Stainless Steel
SMS Furnished

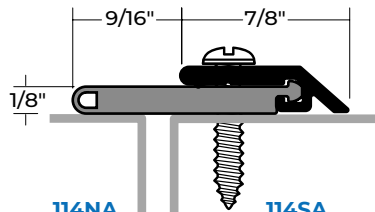

114NA
114NDKB
Neoprene



114SA
114SDKB
Silicone

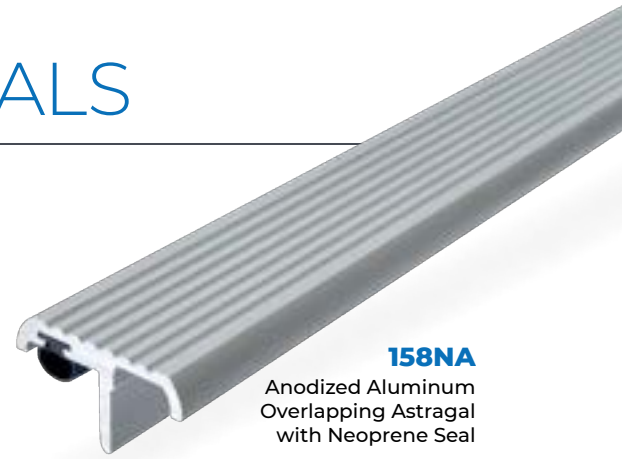

158NA
Anodized Aluminum
Overlapping
Astragal
with Neoprene Seal

PRODUCT#	SUFFIX	FINISH
	A	Anodized Aluminum
	DKB	Dark Bronze / Black Anodized
	None	Mill Aluminum

*Pile is Gray
Vinyl, Neoprene and
Silicone are Black*

158VA
158VDKB
Vinyl



158NA
158NDKB
Neoprene

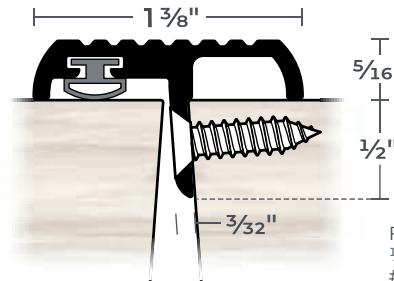

Maximum
Height 120"

Fits Beveled Edge Doors with
1/8" Clearance Between Doors.
#10 X 3/4" FH U/C SMS Furnished

158SA
158SDKB
Silicone

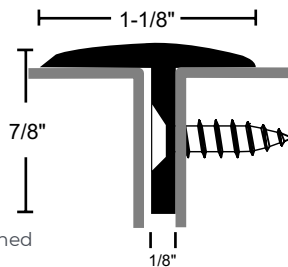

176A
176DKB

Maximum Height 120"
Fits Square Edge Doors
#10 X 3/4" FH U/C SMS Furnished

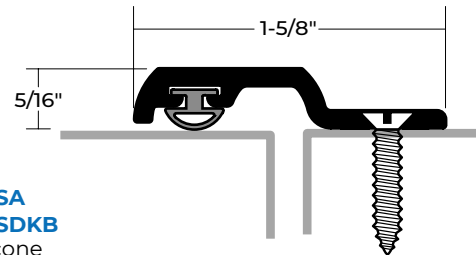

178SA
178SDKB
Silicone



Maximum Height 120"
#10 X 3/4" FH U/C SMS Furnished

SPECIALTY ASTRAGAL

For 1 3/4" Doors:
14RA-1 3/4"
14RDKB-1 3/4"

For 2 1/4" Doors:
14RA-2 1/4"
14RDKB-2 1/4"

Rubber is Black
Order as Set to
Receive Two Pieces

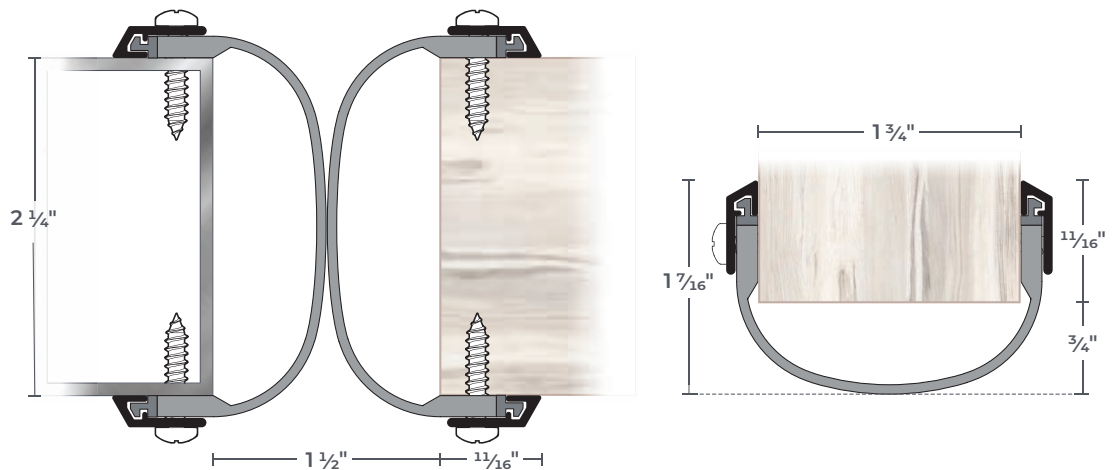

SOLID METAL ASTRAGALS

- ▶ 1/16" Thick Lead Insert Available – Specify "Lead-Lined"
- ▶ Available with SNB, Specify

139SP Steel Prime Coat

139SPDKB Steel Dark Bronze



Furnished with #12 x 1 1/4" SMS.
Can Replace Astragal Required by the Door Manufacturer on Wood or Metal Fire-Rated Doors. IBC, NFPA80, NFPA 252 Require the Gap at the Meeting Edge Between Fire Labeled Doors Must Not Exceed 1/8". Astragal Must Overlap Gap and Inactive Door Minimum of 3/4".

139A Anodized Aluminum

139DKB Aluminum Dark Bronze / Black Anodized

#10 x 3/4" SMS Furnished

139SS Stainless Steel

Type 304 Brushed #4 Finish (US32D, 630)

#10 x 3/4" SMS Furnished



139SP
Steel Astragal

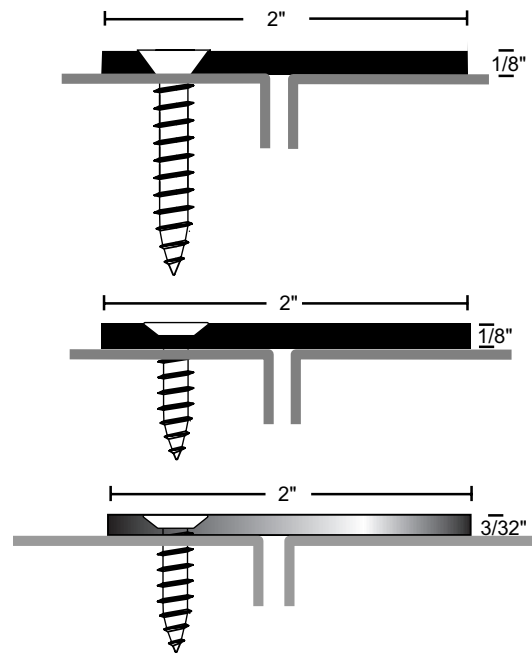

STEEL SECURITY ASTRAGALS

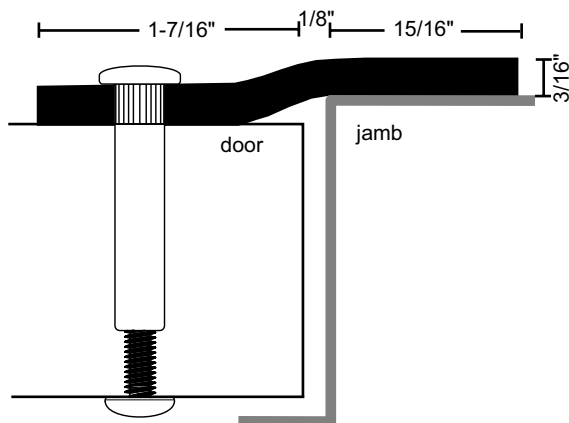

1392SP Steel Prime Coat



Maximum Height 120"
#1/4-20 SNB's Furnished

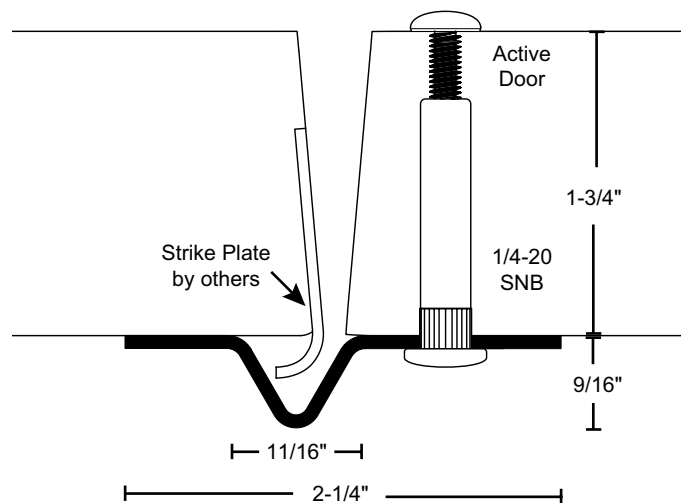

1390SP-83-1/8" 14 Ga. Galvanneal Steel

No Notching or Field Cutting
Needed for Curved Lip Strikes

1390SP-95-1/8" Prime Coat



MORTISED ASTRAGALS

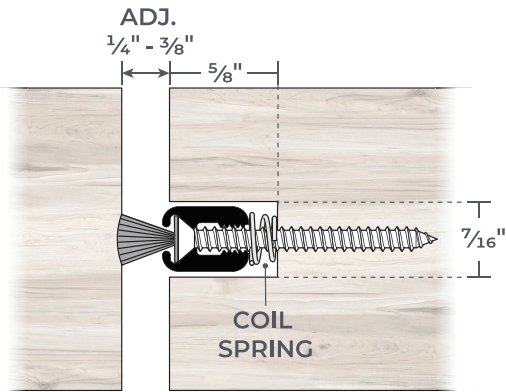

143PA
143PDKB
Polypropylene Pile
#6 SMS Furnished

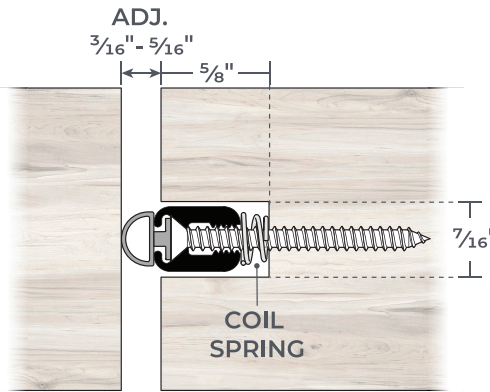

143NA
143NDKB Neoprene
143SA
143SDKB Silicone
#6 SMS Furnished

143PA
Anodized Aluminum
Mortised Astragal with
Pile Seal

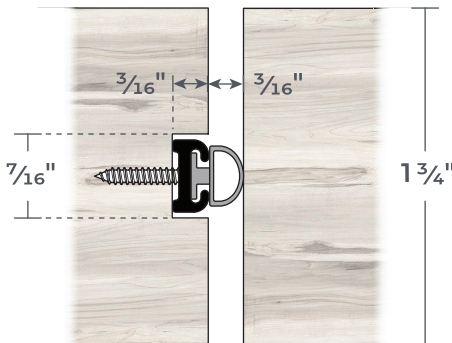

136N
136NDKB
Neoprene



Mortise Dimensions $\frac{7}{16}$ " Wide x
Desired Depth. #2 SMS Furnished

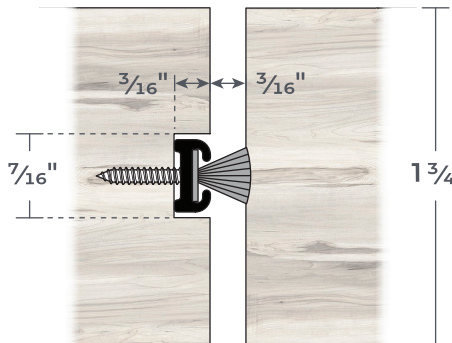

136S
136SDKB
Silicone



136P
136PDKB
Polypropylene Pile

Mortise Dimensions $\frac{7}{16}$ " Wide x
Desired Depth. #2 SMS Furnished

PRODUCT#	FINISH
SUFFIX	
A	Anodized Aluminum
DKB	Dark Bronze / Black Anodized
None	Mill Aluminum

Nylon Brush and Pile are Gray
Vinyl, Neoprene and
Silicone are Black
-BB = Black Brush*

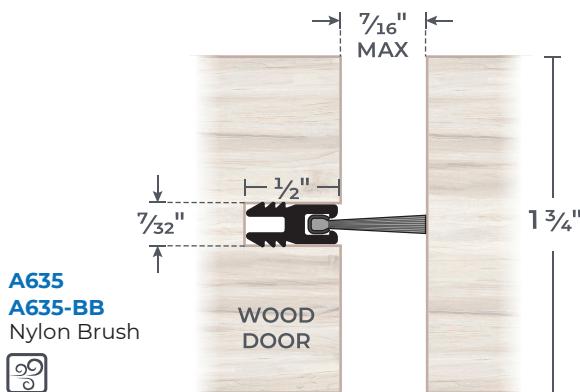

A635
A635-BB
Nylon Brush



Order as **Set** to Receive Two Pieces
Maximum Length 108"

151N
Neoprene

151S
Silicone

151V
Vinyl

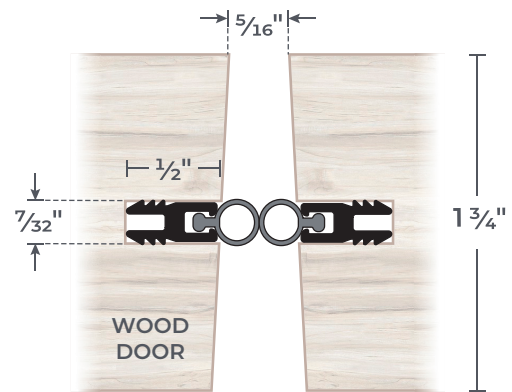

Mortise Dimensions $\frac{7}{32}$ " Wide x $\frac{1}{2}$ "
Order as **Set** to Receive Two Pieces
Maximum Length 108"

SPRING ADJUSTABLE MORTISED ASTRAGALS

- Adjustment Screws on 10" Centers Allow Adjustment of the Seal Without Repositioning Mounting Location
- Spring-Loaded to Maintain Constant Pressure for the Most Effective Seal

PRODUCT#	SUFFIX	FINISH
	A	Anodized Aluminum
	DKB	Dark Bronze / Black Anodized
<i>Pile is Gray Silicone is Black</i>		

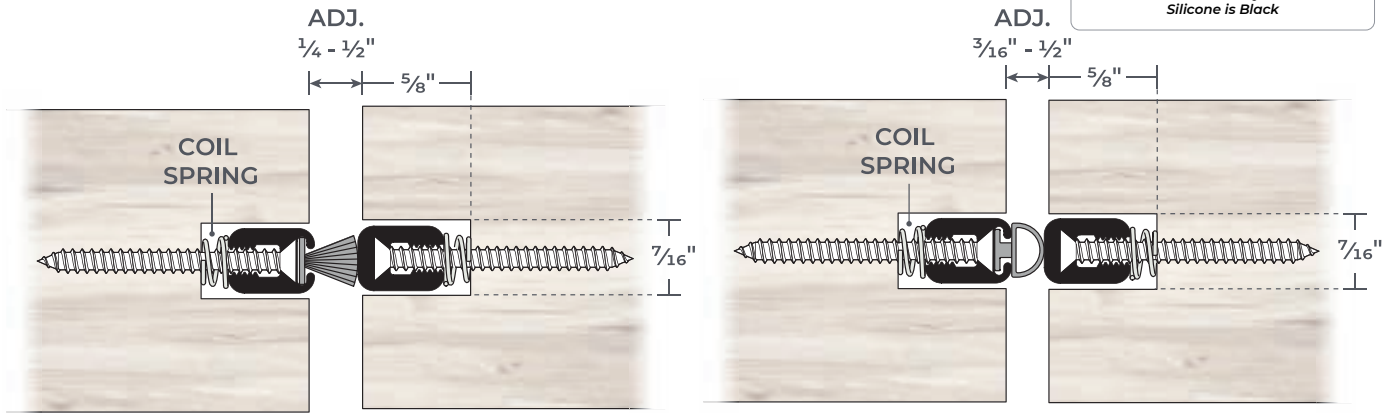

144PA
144PDKB
Polypropylene Pile

Mortise Dimensions $\frac{3}{16}$ " Wide x $\frac{7}{8}$ "
#8 x $\frac{3}{4}$ " SMS Furnished
Provided as Two-Piece Set

144SA
144SDKB
Silicone

Mortise Dimensions $\frac{3}{16}$ " Wide x $\frac{7}{8}$ "
#8 x $\frac{3}{4}$ " SMS Furnished
Provided as Two-Piece Set



SELF-ADHESIVE PILE ASTRAGALS

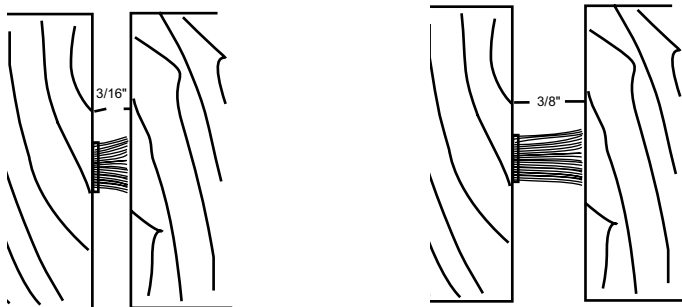

340P
Gray Polypropylene Pile

336P
Gray Polypropylene Pile

SAFETY SEAL FOR DOUBLE-ACTING DOORS

- Seals and Closes Gap at Heel of Double-Acting or Center Pivoted Doors
- #6 x $\frac{3}{4}$ " Stainless Steel Sheet Metal Screws Furnished

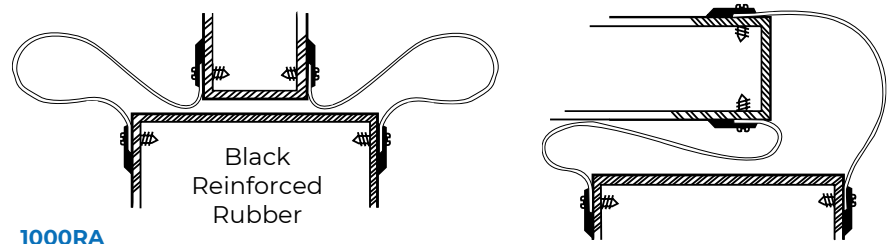

1000RA
1000RDKB

5", 10" or 16" Overall Widths Available - Specify
Order as Set to Receive Two Pieces

GUARDS / SEALS

RAIN DRIP GUARDS

- ▶ #6 x 3/4" Stainless Steel SMS Furnished

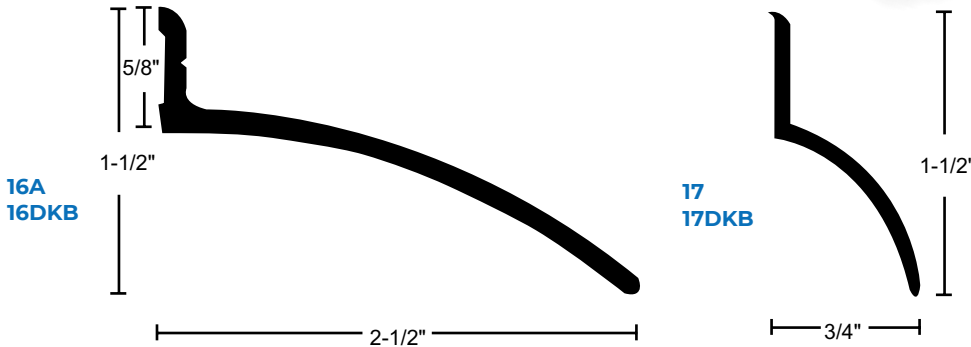

16A
Anodized Aluminum
Drip Strip

PRODUCT# SUFFIX	FINISH
A	Anodized Aluminum
DKB	Dark Bronze / Black Anodized
None	Mill Aluminum

MAGNETIC SEALS

- ▶ #6 x 3/4" Stainless Steel SMS Furnished
- ▶ Screw Holes Slotted for Adjustment
- ▶ Maximum Length 120"

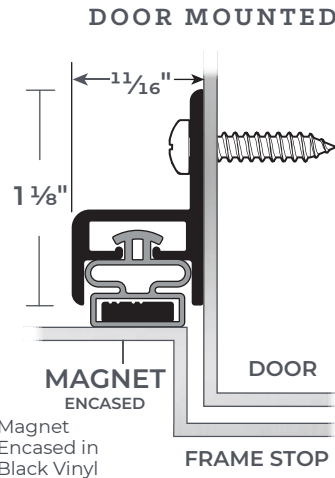
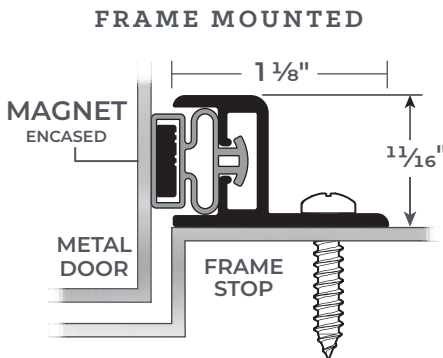

159MA
Anodized Aluminum
Magnetic Seal

159MA
159MDKB



CUSHION BRONZE WEATHERSTRIP

- ▶ Cushion Material Will Not Coil. Specify Lengths Required (36", 48", 72" 86", And 96".) Nails Not Included
- ▶ Normal Installation Requires 3/4 lb. of Nails Per 100 ft. of Weatherstrip; Install 2" O.C. Zinc Plated Bronze Finish Nails Available in 1 lb. Bags
- ▶ Wafer Head Pilot Point Drive Nails Make Excellent Applications for Metal Jambs, Normal Installation Requires 6 Per Foot
- ▶ Install Using #41 Drill Bit. Available with Fast Attach Tape - Specify X "FATT"

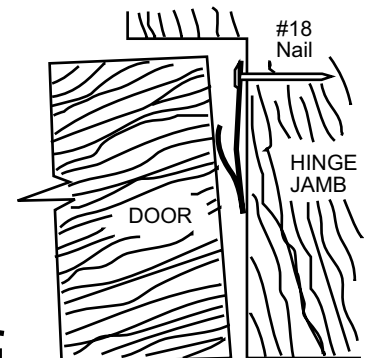
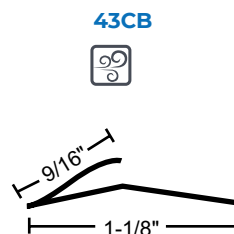

43CB

GASKETING FASTENERS



#2 x 1/2" FH
Phillips SMS



#4 x 5/8" TH
Phillips SMS
Use 5/64" Drill



#6 x 1/2" FH
Phillips SMS
Use 7/64" Drill



Phillips Head
Top View



Spanner Head
Top View



Torx Security
Top View

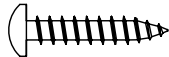

#6 x 3/4" PH
Phillips SMS
Use 7/64" Drill

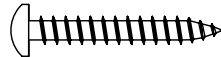

#6 x 1" PH
Phillips SMS
Use 7/64" Drill



#6 x 1 1/2" PH
Phillips SMS
Use 7/64" Drill

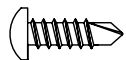
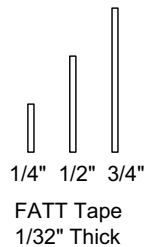

#6 x 1/2"
Phillips
TEK Screw



#6 x 3/4"
Phillips
TEK Screw



#6 x 1"
Phillips
TEK Screw

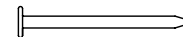

#18 x 7/8" Nail for
Spring/Cushion
Bronze Weather Strip
on Wood Jamb



#8 x 3/4" PH
Phillips SMS
Use 9/64" Drill



#8 x 3/4"
Phillips
TEK Screw

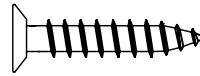

#8 x 1" FH
Phillips U/C SMS
Use 9/64" Drill

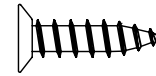

#10 x 3/4" FH
Phillips U/C SMS
Use 11/64" Drill

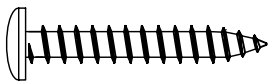

#8 x 1 1/4" TH
Phillips SMS
Use 9/64" Drill

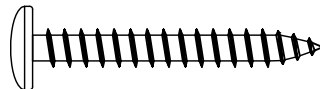

#10 x 1 1/2" TH
Phillips SMS
Use 11/64" Drill



#4 Wafer Head Drive Nail
for Spring/Cushion
Bronze Weather Strip
on Metal Jamb
Use #41 Drill Bit for Pilot Hole

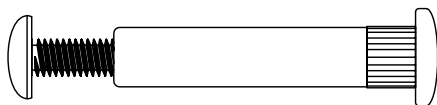

#1/4 - 20 Phillips SNB

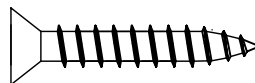

#12 x 1 1/4" FH
Phillips SMS

PH = Pan Head
FH = Flat Head
TH = Truss Head
MS = Machine Screw
SMS = Sheet Metal Screw
SNB = Sex Nut & Bolt
U/C = Undercut

NOTES

NOTES



For the most up-to-date
Gasketing
Catalog scan the QR code
or visit ngp.com.



ngp.com
1-800-NGP-RUSH

FAX: (800) 255-7874
QUOTES: quotes@ngp.com
ORDERS: orders@ngp.com

NGP MEMPHIS
4985 East Raines Road
Memphis, TN 38118

CARSON CITY
3689 Arrowhead Drive
Carson City, NV 89706