

# STI Weather Stopper II®



STI-3150



## PRODUCT OVERVIEW

Large weatherproof cover designed to protect devices such as external call points. The Weather Stopper II is a tough, clear polycarbonate cover designed to protect manual call points and other devices where protection from the environment is necessary, such as car parks, food processing factories and swimming pools. It is also ideal for saline atmospheres. It is available for flush or surface mounted devices with a variety of cable entry gaskets.

## HOW IT WORKS

The Weather Stopper II consists of a clear, tamperproof, tough polycarbonate cover, frame and weather gasket that retrofits over the existing device. The weather gasket seals the unit preventing dust, grime and water from getting to the device. In the event of an emergency, simply lift the cover to gain access to the protected device.

## KEY FEATURES

### General Information

- Large weatherproof cover to protect devices such as external call points.
- Three year guarantee against breakage of polycarbonate in normal use.

### Design

- Prevents ingress of dust or water, without hindering legitimate operation of a manual call point in the event of an emergency.
- Retrofit cover is built to meet the requirements of IP54.

### Construction

- Tough polycarbonate housing can withstand the severest of knocks.

### Installation

- A simple 4 fixing installation can retrofit over existing device.
- Can accommodate flush or surface mounted applications.
- Typical working properties of polycarbonate are -40°C to 121°C (-40° to 250°F)

### Options

- Custom labelling available.

# STI Weather Stopper II®

Dimensions and Technical Information

## MODELS AVAILABLE

- STI-1250** Weather Stopper II flush mounted (includes weather gasket set)
- STI-3150** Weather Stopper II surface mounted (includes 50mm spacer & weather gasket set)

### Text Options:

**Standard Text:** IN CASE OF FIRE - LIFT COVER / ACTIVATE FIRE ALARM

### Accessories:

- STI-3100** 50mm spacer (supplied with STI-3150)
- STI-1280** Backplate (for irregular surfaces)
- STI-3002** Weather gasket set (supplied with STI-1250 & STI-3150)

## APPROVALS

It has been tested and approved or listed by:

- UL/cUL Listed No. S2466
- For fire alarm applications, UL38 requires outdoor listed stations for outdoor use.
- Flush models ADA compliant. Surface models ADA compliant for operation (UL certified No. S2466.)
- Weather models designed to meet the requirements of IP54.
- The indoor/outdoor rated station covers, when mounted on a smooth surface, provide a rain tight seal similar to a 3R enclosure rating.

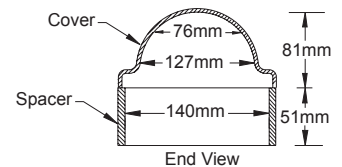
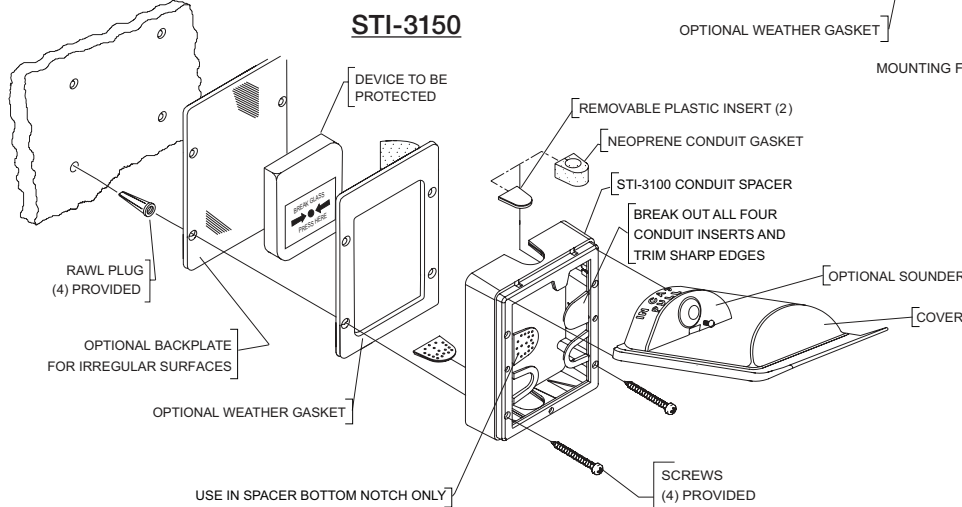
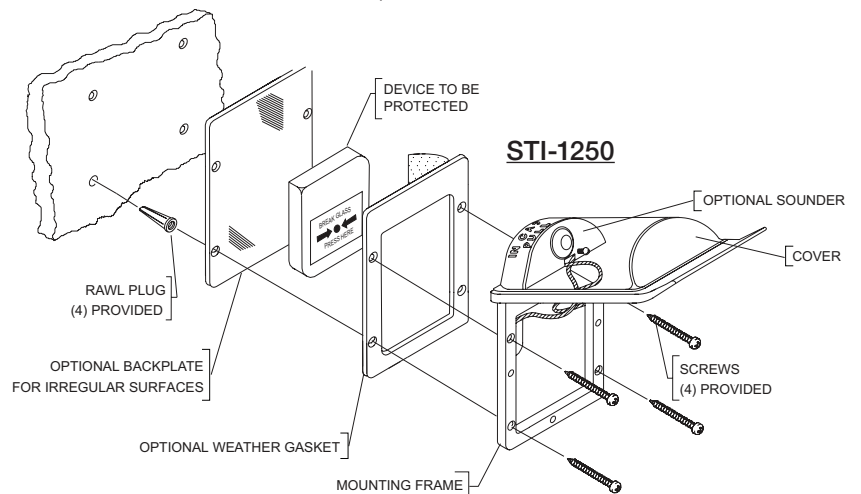
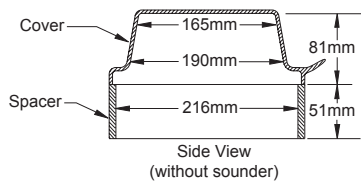
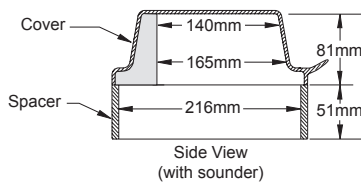
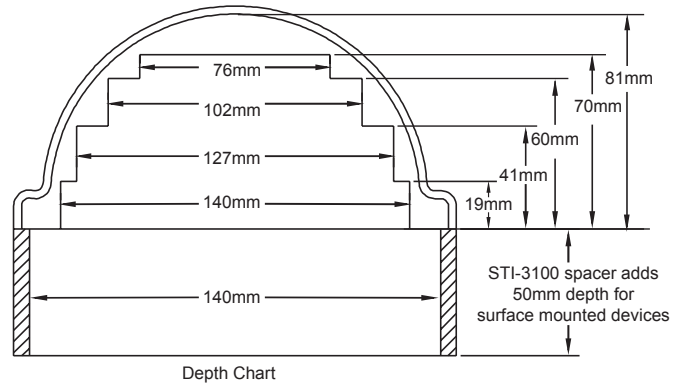

**Safety Technology International**

Taylor House  
34 Sherwood Road  
Bromsgrove  
Worcestershire  
B60 3DR, England

Tel: +44 (0)1527 520 999  
Fax: +44 (0)1527 501 999  
info@sti-emea.com  
www.sti-emea.com

2306 Airport Road  
Waterford, Michigan  
48327, USA

Tel: 248-673-9898  
Fax: 248-673-1246  
Toll-free: 0800-888-4784  
info@sti-usa.com  
www.sti-usa.com