

**FLUSH MOUNT
(STI 9110)**

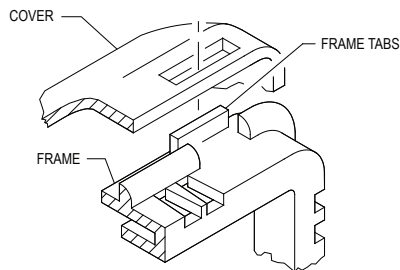

VIEW A

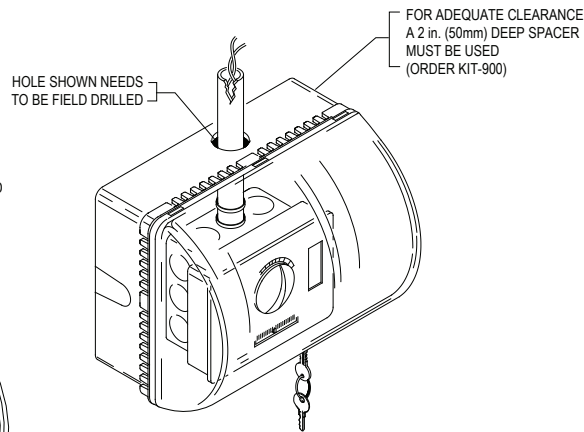

**FOR SURFACE MOUNT
STI-9110 AND KIT-900**

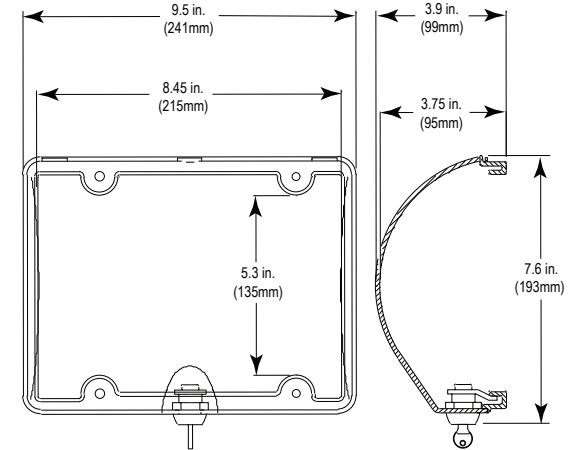

INSTALLATION INSTRUCTIONS

1. Do not remove thermostat. Prior to drilling anchor holes, cover thermostat with a damp cloth to prevent dust from penetrating the sensor.
2. Center frame over existing thermostat. Mark and drill (4) anchor holes using a 1/4 in. (6.3mm) drill bit. Insert the (4) anchors and complete installation as shown.
NOTE: The (3) tabs on the frame must face upward (View A).
3. Insert the (3) slots on the cover over tabs on the top surface of frame. Rotate cover downward onto the frame and turn key to lock.

CLEANING INSTRUCTIONS

To clean cover, remove from wall. Rinse with water to remove abrasive dust and dirt. Wash with soap or mild detergent using a soft cloth (DO NOT SCRUB). Rinse once more, then dry with a soft cloth or chamois. To remove grease or wet paint, rub gently with a cloth wetted thoroughly with naphtha. Then wash and rinse. DO NOT USE RAZOR BLADES.

⚠ WARNING: This product can expose you to chemicals including Dichloromethane, which is known to the State of California to cause cancer, and Bisphenol A (BPA), which is known to the State of California to cause birth defects or other reproductive harm.
For more information go to www.P65Warnings.ca.gov.

Three year warranty or a one year limited warranty (from date of purchase) on most products. See website for details. Electronic warranty form at www.sti-usa.com/wc14.

