



ROCKWOOD®

ASSA ABLOY

Experience a safer
and more open world

ROCKWOOD DOOR PULL CATALOG

Architectural Door Accessories

Table of Contents



Rockwood Company History	4	Square Grip	67
.....		Leather	74
Custom Manufacturing	5	GeoMetek™	74
.....		Accents	75
Architectural Finishes	6	AccenTek™	75
.....		Hexagon	72
Hands-Free Options	9	GeoMetek™	76
.....		Diamond	74
Leather Craftsmanship	10	GeoMetek™	74
.....		Smooth	80
Round Grip	12	PlanTek™	80
Leather	15	GeoMetek™	81
English Bridle	15	
Upholstery	17	Sculpted Pulls	79
Flush	19	Non-Traditional	85
.....		MariTek™	85
Wood	21	MegaCurve™	88
ArborMet™	21	CenTrex™	89
ArborTek™	23	
ArborTek™ with Collars	25	Traditional	92
ArborTek™ with Leather	26	Classic	92
.....		Traditional	94
Santoprene	28	
SoftMet™	28	Architectural Panic Devices	91
SoffTek™	30	Exterior Pull Options	94
.....		
Black Anodized	32	Locking Pull System	95
NoirMet™	32	Locking Door Pull System Options	102
NoirTek™	34	
.....		Locking Door Pull Configurations	103
Grooved	35	
LineaMax™	35	Horizontal Push/Pull Bar Configurations	104
Groove	38	
.....		Sliding and Closet Pulls	101
Smooth	39	Sliding	108
MegaTek™	39	AccenTek	108
NeoMax™	42	Flush Pulls	106
NeoMetrix™	44	
NeoMitre™	46	Closet	111
NeoCylinder™	48	Closet Pulls	111
.....		Edge Pulls	112
Knurled	50	
.....		Accessories	109
Accents	52	Coat Hooks	115
SkewTek™	52	Door Stops	117
MezzoTek™	54	Push Plates, Pull Plates, and Signage	120
BandWidth™	56	
.....		Custom Door Pulls	121
Essential	58	
RightAngles	58	The Good Design Studio	124
Tubular	60	
Standard	62	Technical Information	125
Standard with Santoprene	63	
.....		Finishes	127
Oval Grip	61		
Leather	67		
Leather Oval	67		
.....			
Smooth	68		
OvalTek™ with Flat Oval Grip	68		
OvalTek™ with True Oval Grip	70		



Rockwood Company History

Rockwood Manufacturing was founded in 1946 by the Gurzenda Family in rural southwestern Pennsylvania. Located in the heart of America's county, the team at Rockwood focuses on the design and manufacturing of quality door hardware for commercial, institutional, and high-end residential buildings.

In our third generation of skilled craftsmen, we develop new products and processes that improve our offering. With strict attention to detail, a selection of top-grade materials, to the application of the finest finishes, the results are durable yet aesthetic products of the highest caliber.

ASSA ABLOY

In 2008 Rockwood Manufacturing Company joined ASSA ABLOY, the global leader in door opening solutions. This partnership significantly increased Rockwood's design and development capabilities and greatly expanded ASSA ABLOY's product offering to our customers. The expansion included the addition of many coordinating products between Rockwood and other ASSA ABLOY Group brands through The Good Design Studio.

When you select a Rockwood stainless steel door pull for your LEED certified building project, you are using a product that is made from a minimum 75% post industrial waste and is 100% recyclable. Additionally, these pulls usually can be refinished to their original appearance any time during the life of the building, eliminating the need for replacement when a renovation is conducted. Because of this, ASSA ABLOY can help to achieve prerequisites and accumulate points in several categories and credit areas of LEED.



ASSA ABLOY is a member of the USGBC and CaGBC. U.S. Green Building Council logo is a trademark owned by the U.S. Green Building Council and is used with permission.





Custom Manufacturing





Design your own hardware! Whether it is a modification of a standard product, a completely unique design, or a custom finish, we will quote your design and offer suggestions for the best mounting applications. We take special pride in our custom products. For more information, please see page 125.



Architectural Finishes

With several architectural finishes to choose from, Rockwood products are finished to the highest quality standards.

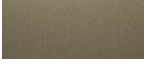
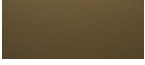
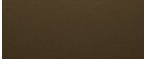
ALUMINUM FINISHES

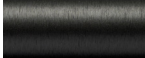
Swatch	Description	US Code	ANSI/ BHMA
	Satin	US27	627
	Clear Anodized	US28	628
	Light Bronze Anodized	311	—
	Medium Bronze Anodized	312	—
	Dark Bronze Anodized	313	710
	Extra Dark Bronze Anodized	314	—
	Black Anodized	315	711







BRASS FINISHES

Swatch	Description	US Code	ANSI/ BHMA
	Polished Clear Coated	US3	605
	Polished No Coating	US3NL	—
	Satin Clear Coated	US4	606
	Satin No Coating	US4NL	—
	Satin Oxidized Relieved	US5	609
	Polished Nickel Plated Clear Coated	US14	618
	Satin Nickel Plated Clear Coated	US15	619
	Satin Nickel Blackened Relieved Clear Coated	US15A	620
	Polished Chrome Plated	US26	625
	Satin Chrome Plated	US26D	626

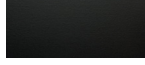
BRONZE FINISHES

Swatch	Description	US Code	ANSI/ BHMA
	Polished Clear Coated	US9	611
	Satin Clear Coated	US10	612
	Satin Black Oxidized Oil Rubbed	US10A	—
	Satin Oxidized Oil Rubbed	US10B	613
	Satin Oxidized Clear Coated	US10BL	614
	Dark Oxidized Statuary Clear Coated	US20A	624

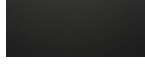
POWDER COAT FINISHES

Swatch	Description	US Code	ANSI/ BHMA
	Flat Black Powder Coat	US19 (FBPC)	622
	Dark Oxidized Satin Bronze, Equivalent	10BE	(613E)
	Black Powder Coat (gloss)	BPC	—
	Red Powder Coat	RPC	—
	White Powder Coat (gloss)	WPC	—
	Black Suede Powder Coat (matte)	BSP	—
	White Suede Powder Coat (matte)	WSP	—

STAINLESS STEEL FINISHES

Swatch	Description	US Code	ANSI/ BHMA
	Polished Stainless Steel	US32	629
	Polished MicroShield® Coated	US32MS*	—
	Polished 316 Alloy	US32316*	—
	Satin Stainless Steel	US32D	630
	Satin MicroShield® Coated	US32DMS*	—
	Satin 316 Alloy	US32D316*	—

* Available on select items.

For finish availability by product series, see the Finish Matrix on pages 130-131.

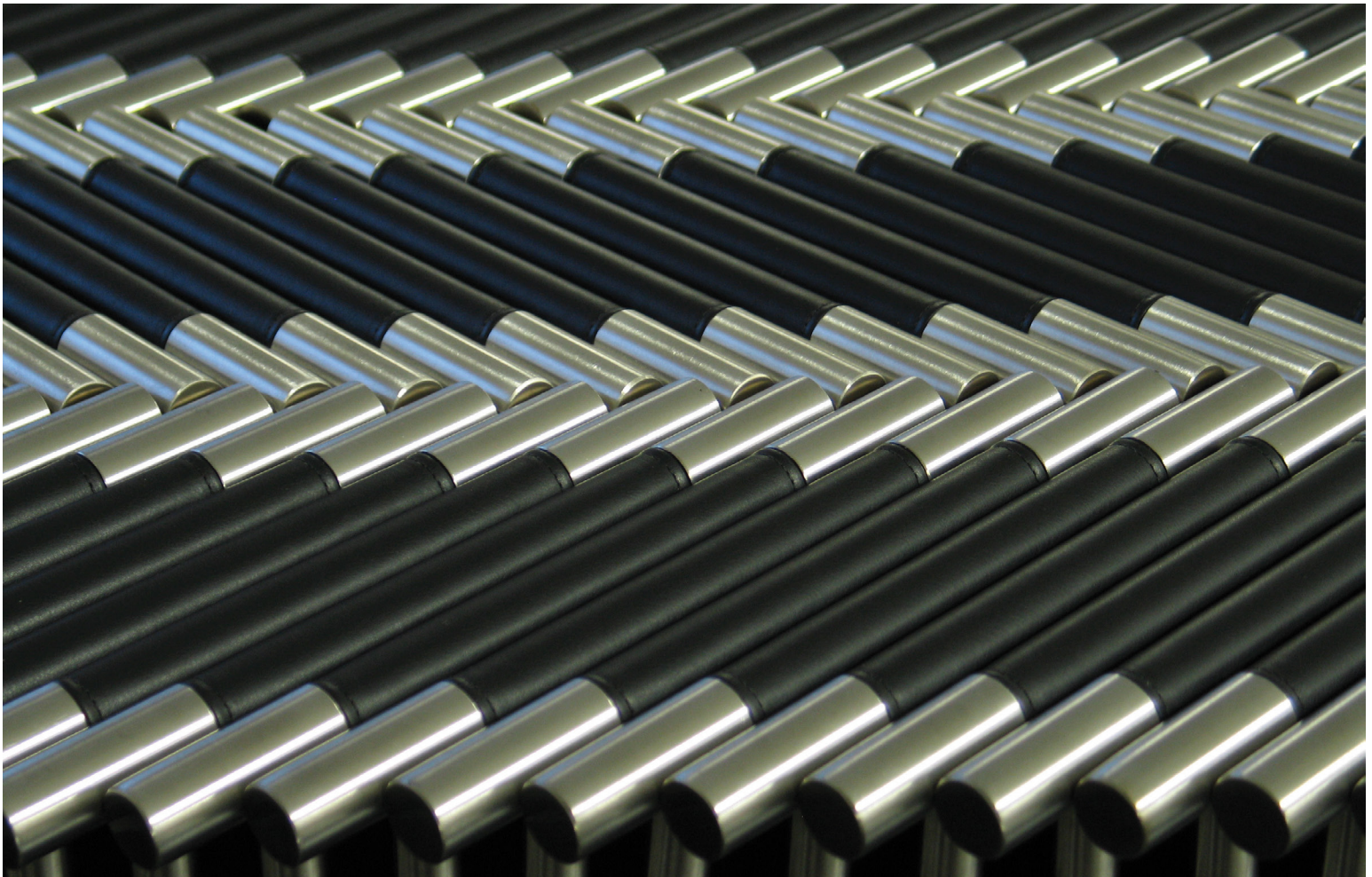

SPECIAL FINISHES DESCRIPTIONS

US32DMS (MicroShield®): ASSA ABLOY Group companies offer MicroShield®, an anti-microbial coating for door hardware. MicroShield uses proven silver ion-based technology from Agion®, a leading provider of antimicrobial solutions, to stem the spread of bacteria and other microbes.

MicroShield® is a registered trademark of Yale Security Inc., an ASSA ABLOY Group company.

US32316 and US32D316 are made from alloy 316 stainless steel containing molybdenum and extra nickel giving it substantially higher corrosion resistance than the standard stainless steels typically used in door hardware. This finish is ideal for use in coastal, urban, and industrial areas that have harsh environmental conditions.

SPECIAL POWDER COAT FINISH DESCRIPTION

10BE Dark Oxidized Satin Bronze equivalent:

This finish provides the richness and warmth of the 10B/613 “living” finish, but maintains its original color and appearance and will not fade or wear over time. The 10BE finish is offered by Corbin Russwin, McKinney Products, Norton Rixson, Rockwood Products, SARGENT and ASSA ABLOY ACCENTRA™ (formerly Yale Commercial), providing visual consistency between ASSA ABLOY Group brands.

Black Suede (BSP) is a permanent matte finish that conveys sophisticated elegance. Tested to ANSI/BHMA A156.18 standards, BSP delivers a “suede-like” feel.



The Agion antimicrobial is not intended as a substitute for good hygiene. Coated products must still be cleaned to ensure the surfaces will be free of destructive microbes. ASSA ABLOY makes no representations or warranties, express or implied, as to the efficacy of the Agion antimicrobial. A copy of the Agion warranty is available upon request. Agion is a registered trademark of Agion Technologies, Inc., Wakefield, MA, USA



Finish Tips

STAINLESS STEEL

Stainless steel is one of the most dependable materials used in architecture. There are many types, each with different properties and different levels of corrosion resistance. For most indoor (except chlorine and other harsh chemical exposure) and many outdoor (mildly corrosive) environments, our standard stainless steel performs exceeding well and is best maintained with periodic water washing. If your job site has road salt, marine salt air, industrial, or urban pollution, we recommend the use of molybdenum bearing alloy 316 stainless steel. Specify US32316 or US32D316.

To enhance the corrosion resistance of stainless steel, use the polished finish (US32) in place of the satin finish (US32D). The mirror smooth surface of the polished finish has no rough surface to retain the microscopic dirt or debris that promotes corrosion.

HEAT RESISTANT

Exterior hot and sunny climates call for a finish that is resistant to heat. We recommend our white powder coat finish. This durable exterior finish reflects many of the heat rays and is substantially cooler to the touch than stainless steel or other finishes.

BACTERIAL PROTECTION

MicroShield® (US32DMS) is the ideal finish for hospitals, schools, laboratories, assisted living facilities, public restroom areas, and anywhere there are concerns about controlling bacteria growth and meeting demanding standards of cleanliness. Contact our customer service department for more detailed information.

FINISH SAMPLE DISPLAYS

Educational and informative displays are available showing our most popular finishes.



HANDS-FREE OPTIONS

Cut down your exposure to germs while maintaining good design with handsfree options for Rockwood MegaTek and NoriTek Architectural Pulls. You can now configure these popular door pulls with extended posts and/or closer posts, to easily allow for arm to be placed above, below, or through the pull, limiting touchpoints.

Rockwood Hands-Free Door Pulls are part of a continuum of Safer2Open™ low-touch and touchless door hardware solutions from ASSA ABLOY.

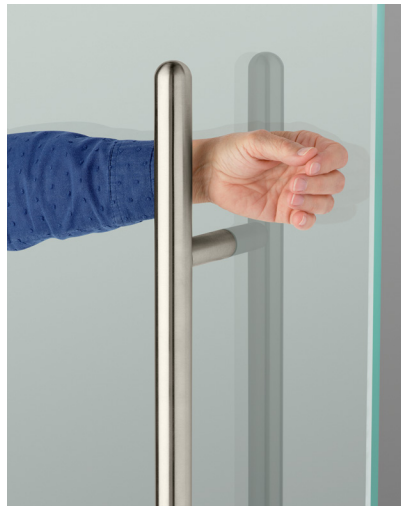



Leather Craftsmanship

Rockwood products use the finest bridle and upholstery leathers, hand-sewn by a talented craftsman. A selection of standard leather colors is available, as well as a plethora of custom colors and threading options. The custom leather covering options are endless. From minor design changes or unique custom creations, we are dedicated to making the door pull of your dreams.

MAINTENANCE

All leather pulls leave our factory with an initial coating of leather dressing. Upholstery Leather has a breathable protective finish that is best cleaned by wiping with a cool damp cloth. For tougher soiling, use a pH balanced soap on a cloth and rinse; always use cool water. Repeat if necessary. Do not use wax, mink oil, saddle soap, or polishes on upholstery leather. Occasional use of a finished leather cleaner, conditioner, and protector is recommended. Clean English Bridle Leather as necessary with a damp cloth and allow to dry. Apply a light coat of leather care product, allow to dry and buff with a soft cloth.

FINISHES

Leather wrapped door pulls are offered in brass, bronze, and stainless steel base materials in a wide variety of architectural finishes.



LEATHER

Rockwood products use 8–10 ounces of hand-colored, vegetable-tanned English Bridle leather, the finest leather in the world, so you can be assured of a beautiful and durable leather door pull.

In addition to our selection of fine English Bridle and Upholstery leathers, you may specify a custom leather application, including color, thread, and stitching. Minimum charges apply for special order leather.

STANDARD COLOR SELECTIONS

ENGLISH BRIDLE LEATHER



B-LBRN
(Light Brown)



B-BUR
(Burgundy)



B-MBRN
(Medium Brown)



B-DBRN
(Dark Brown)



B-BLK
(Black)

UPHOLSTERY LEATHER



U-DBRN
(Dark Brown)



U-BLK
(Black)



Round Grip

Discover the clean, smooth simplicity of our round grip design, infused with eye-catching elements for added interest. Select the collection that makes your vision a reality. From contrasting, contemporary effects to subtle-toned natural warmth, a variety of size and finish options are available to compliment any door concept.



LEATHER

Expansive selection of high-quality, durable, leather door pulls

WOOD

Naturally unique markings and tones with exotic elegance and alluring warmth

SANTOPRENE™

Pure comfort in high-performance engineered thermoplastic elastomer grips

BLACK ANODIZED

Durability with the high-visibility contrast of satin-black, hard-coat anodized aluminum

GROOVED

Unmatched contemporary fashion in the smooth transition of precision-fitted joints amid solid ends and expertly grooved tubing

SMOOTH

Simple, attractive, with contemporary design elements

KNURLED

Textured designs that produce a better gripping surface while enhancing the aesthetics of your door opening

ACCENTS

Interesting design elements move beyond the commonplace and into the extraordinary

ESSENTIAL

Industry-standard, uncomplicated forms for a basic composition

RM6060 - RM6092
RM6700 - RM6730

ENGLISH BRIDLE
LEATHER

B-LBRN
(Light Brown)

B-BUR
(Burgundy)

B-MBRN
(Medium Brown)

B-DBRN
(Dark Brown)

B-BLK
(Black)

LEATHER

English Bridle

Vegetable-tanned, English Bridle leather is hand-colored in one of many beautiful shade selections. These pulls are tightly-wrapped and sewn with detail on the ends and back of the pull, for a truly tailored look.



STRAIGHT PULLS -
FLAT ENDS

Part	Dia.	Proj.
RM6060	1"	2 ³ / ₄ "
RM6061†	1 ¹ / ₄ "	3"
RM6062	1 ¹ / ₂ "	3 ¹ / ₄ "

† For locking pull options, see page 105.

* Black leather is shown.



OFFSET PULLS -
FLAT ENDS

Part	Dia.	Proj.
RM6070	1"	2 ¹ / ₂ "
RM6071	1 ¹ / ₄ "	2 ³ / ₄ "
RM6072	1 ¹ / ₂ "	3"

* Black leather is shown.



STRAIGHT PULLS -
ROUND ENDS

Part	Dia.	Proj.
RM6080	1"	2 ³ / ₄ "
RM6081	1 ¹ / ₄ "	3"
RM6082	1 ¹ / ₂ "	3 ¹ / ₄ "

* Black leather is shown.



OFFSET PULLS -
ROUND ENDS

Part	Dia.	Proj.
RM6090	1"	2 ¹ / ₂ "
RM6091	1 ¹ / ₄ "	2 ³ / ₄ "
RM6092	1 ¹ / ₂ "	3"

* Black leather is shown.



SMALL FULL WRAPPED
STRAIGHT PULLS -
FLAT ENDS

Part	Dia.	Proj.
RM6700	1/2"	1 ³ / ₈ "
RM6710	5/8"	1 ¹ / ₂ "

* Burgundy leather is shown.



SMALL FULL WRAPPED
OFFSET PULLS -
FLAT ENDS

Part	Dia.	Proj.
RM6730	5/8"	1 ¹ / ₈ "

* Black leather is shown.

Contact factory for custom color options.
Projection shown excludes leather thickness.

RM6160 – RM6192
 RM6500 – RM6570

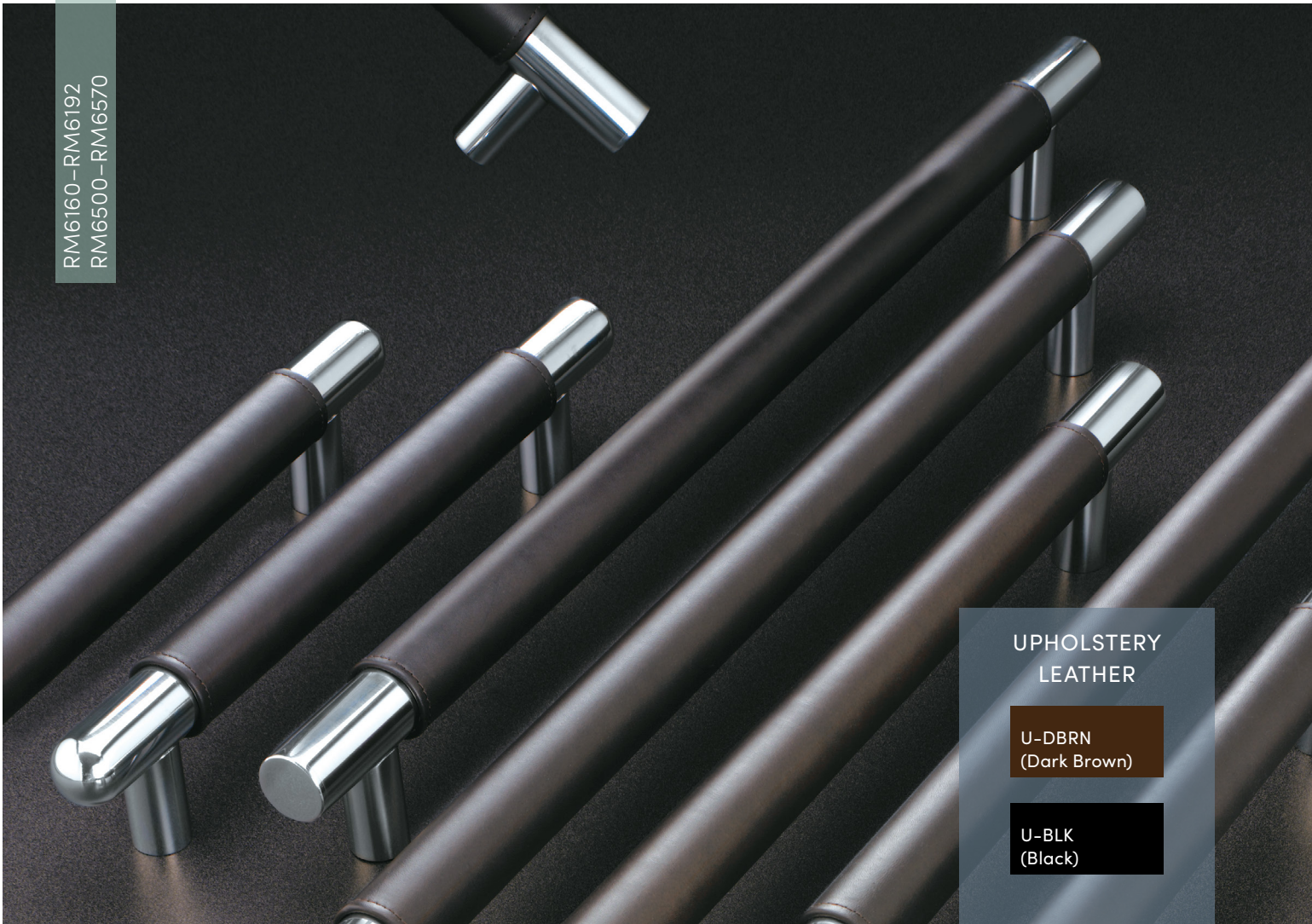

**UPHOLSTERY
 LEATHER**

U-DBRN
 (Dark Brown)

U-BLK
 (Black)

LEATHER

Upholstery

Add a glove-soft leather feel to any interior door. Available in both standard and custom colors, these tanned leather pulls are tightly-wrapped stitching, for a beautifully detailed look.



STRAIGHT PULLS -
 FLAT ENDS

Part	Dia.	Proj.
RM6160	1"	2 ³ / ₄ "
RM6161†	1 ¹ / ₄ "	3"
RM6162	1 ¹ / ₂ "	3 ¹ / ₄ "

† For locking pull options, see page 105.

* Dark Brown leather is shown.



OFFSET PULLS -
 FLAT ENDS

Part	Dia.	Proj.
RM6170	1"	2 ¹ / ₂ "
RM6171	1 ¹ / ₄ "	2 ³ / ₄ "
RM6172	1 ¹ / ₂ "	3"

* Dark Brown leather is shown.



**STRAIGHT PULLS -
ROUND ENDS**

Part	Dia.	Proj.
RM6180	1"	2 ³ / ₄ "
RM6181	1 ¹ / ₄ "	3"
RM6182	1 ¹ / ₂ "	3 ¹ / ₄ "

* Dark Brown leather is shown.



**OFFSET PULLS -
ROUND ENDS**

Part	Dia.	Proj.
RM6190	1"	2 ¹ / ₂ "
RM6191	1 ¹ / ₄ "	2 ³ / ₄ "
RM6192	1 ¹ / ₂ "	3"

* Dark Brown leather is shown.



**SMALL STRAIGHT PULLS -
FLAT ENDS**

Part	Dia.	Proj.
RM6500	1/2"	1 ³ / ₈ "
RM6510	5/8"	1 ¹ / ₂ "

* Burgundy leather is shown.
* Also available in English Bridle.



**SMALL OFFSET PULLS -
FLAT ENDS**

Part	Dia.	Proj.
RM6530	5/8"	1 ⁷ / ₈ "

* Burgundy leather is shown.
* Also available in English Bridle.



**SMALL STRAIGHT PULLS -
ROUND ENDS**

Part	Dia.	Proj.
RM6540	1/2"	1 ³ / ₈ "
RM6550	5/8"	1 ¹ / ₂ "

* Burgundy leather is shown.
* Also available in English Bridle.



**SMALL OFFSET PULLS -
ROUND ENDS**

Part	Dia.	Proj.
RM6570	5/8"	1 ⁷ / ₈ "

* Burgundy leather is shown.
* Also available in English Bridle.



**STRAIGHT PULL - ROUND
POSTS - D-TUBE ENDS**

Part	Grip Size	Proj.
RM6141	1" x 1 ¹ / ₄ "	2 ³ / ₄ "

* Dark Brown leather is shown.



**OFFSET PULL - ROUND
POSTS - D-TUBE ENDS**

Part	Grip Size	Proj.
RM6151	1" x 1 ¹ / ₄ "	2 ¹ / ₂ "

* Dark Brown leather is shown.

Contact factory for custom color options.
Projection shown excludes leather thickness.

RM6300 – RM6354
RM6610 – RM6670

ENGLISH BRIDLE
LEATHER

B-LBRN
(Light Brown)

B-BUR
(Burgundy)

B-MBRN
(Medium Brown)

B-DBRN
(Dark Brown)

B-BLK
(Black)

UPHOLSTERY
LEATHER

U-DBRN
(Dark Brown)

U-BLK
(Black)

LEATHER

Flush

Classic pulls that unite a welcoming leather style with clean, contemporary lines. These wrapped leather pulls highlight the smooth, fitted transition between solid metal ends and a detailed leather grip.



STRAIGHT PULLS -
FLAT ENDS

Part	Dia.	Proj.
RM6300	1"	2 ³ / ₄ "
RM6310	1 ¹ / ₄ "	3"
RM6320	1 ¹ / ₂ "	3 ¹ / ₄ "

* Medium Brown leather is shown.



OFFSET PULLS -
FLAT ENDS

Part	Dia.	Proj.
RM6330	1"	2 ¹ / ₂ "
RM6340	1 ¹ / ₄ "	2 ³ / ₄ "
RM6350	1 ¹ / ₂ "	3"

* Medium Brown leather is shown.



**STRAIGHT PULLS -
ROUND ENDS**

Part	Dia.	Proj.
RM6304	1"	2 ³ / ₄ "
RM6314	1 ¹ / ₄ "	3"
RM6324	1 ¹ / ₂ "	3 ¹ / ₄ "

* Medium Brown leather is shown.



**OFFSET PULLS -
ROUND ENDS**

Part	Dia.	Proj.
RM6334	1"	2 ¹ / ₂ "
RM6344	1 ¹ / ₄ "	2 ³ / ₄ "
RM6354	1 ¹ / ₂ "	3"

* Medium Brown leather is shown.



**SMALL STRAIGHT
PULLS - FLAT ENDS**

Part	Dia.	Proj.
RM6610	5/8"	1 ¹ / ₂ "

* Burgundy leather is shown.



**SMALL OFFSET PULLS -
FLAT ENDS**

Part	Dia.	Proj.
RM6630	5/8"	1 ⁷ / ₈ "

* Burgundy leather is shown.



**SMALL STRAIGHT PULLS -
ROUND ENDS**

Part	Dia.	Proj.
RM6650	5/8"	1 ¹ / ₂ "

* Burgundy leather is shown.



**SMALL OFFSET PULLS -
ROUND ENDS**

Part	Dia.	Proj.
RM6670	5/8"	1 ⁷ / ₈ "

* Burgundy leather is shown.



SCOOPED PULL

Part	Dia.	Proj.
RM6317	1 ¹ / ₃ "	3 ¹ / ₈ "

* Dark Brown leather is shown.



OFFSET PULL

Part	Dia.	Proj.
RM6347	1 ¹ / ₄ "	2 ²³ / ₃₂ "

* Dark Brown leather is shown.

RM4000 – RM4054
RM1510 – RM1570

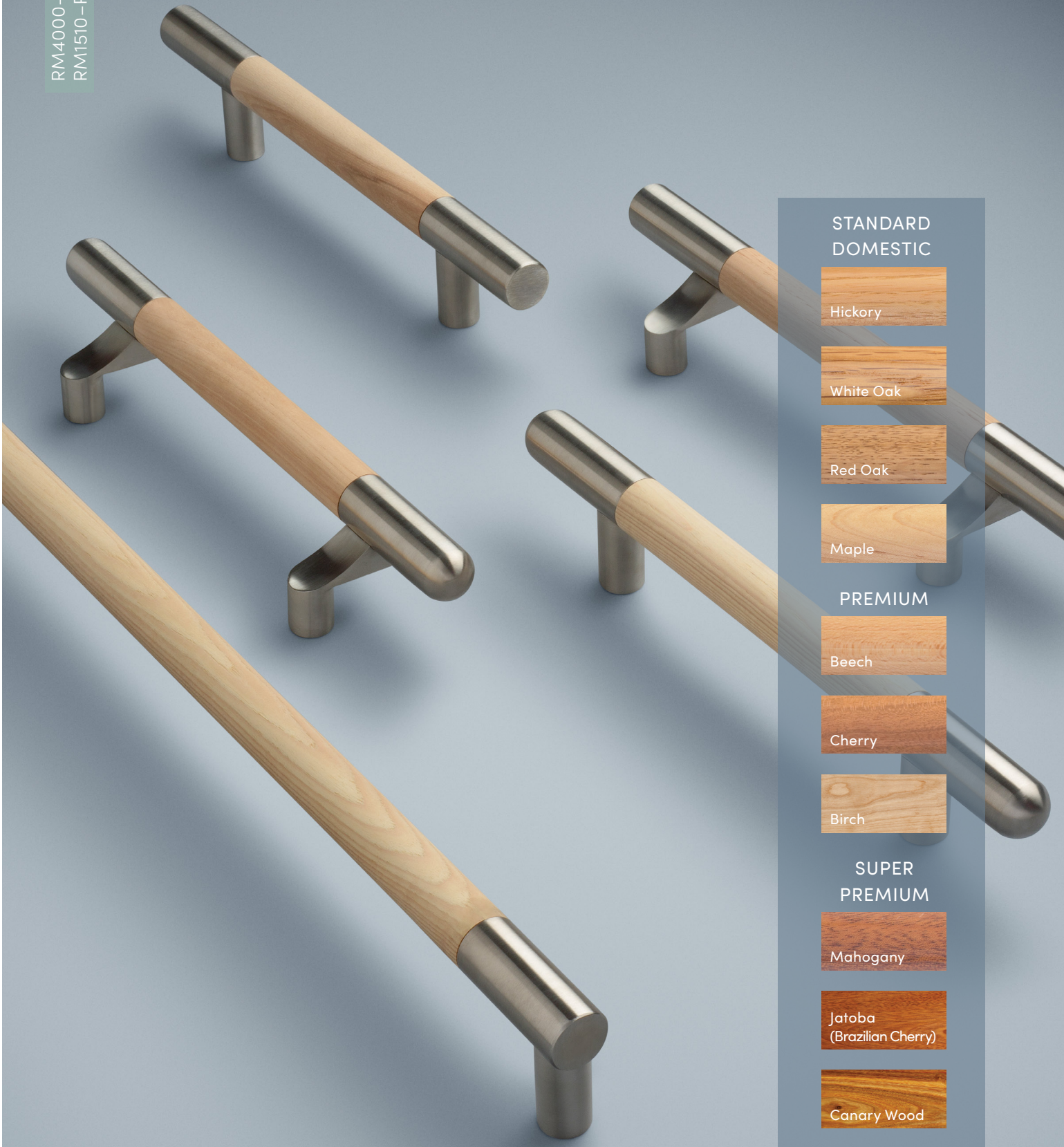

STANDARD
DOMESTIC



Hickory



White Oak



Red Oak



Maple

PREMIUM



Beech

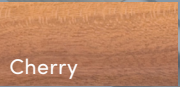

Cherry



Birch

SUPER
PREMIUM



Mahogany



Jatoba
(Brazilian Cherry)

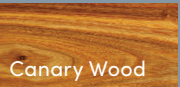

Canary Wood

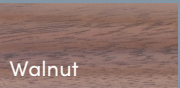

Walnut

WOOD

ArborMet™

Combining the strength of solid brass and stainless steel with the warm feel and varied tones of wood, these pulls add ambiance to any entrance.



STRAIGHT PULLS -
FLAT ENDS

Part	Dia.	Proj.
RM4000	1"	2 ³ / ₄ "
RM4010	1 ¹ / ₄ "	3"
RM4020	1 ¹ / ₂ "	3 ¹ / ₄ "



STRAIGHT PULLS -
ROUND ENDS

Part	Dia.	Proj.
RM4004	1"	2 ³ / ₄ "
RM4014	1 ¹ / ₄ "	3"
RM4024	1 ¹ / ₂ "	3 ¹ / ₄ "



OFFSET PULLS -
FLAT ENDS

Part	Dia.	Proj.
RM4030	1"	2 ¹ / ₂ "
RM4040	1 ¹ / ₄ "	2 ³ / ₄ "
RM4050	1 ¹ / ₂ "	3"



OFFSET PULLS -
ROUND ENDS

Part	Dia.	Proj.
RM4034	1"	2 ¹ / ₂ "
RM4044	1 ¹ / ₄ "	2 ³ / ₄ "
RM4054	1 ¹ / ₂ "	3"



SMALL STRAIGHT PULLS -
VARIOUS ENDS

Part	Dia.	Proj.
RM1510 (Flat)	5/8"	1 ¹ / ₂ "
RM1550 (Round)	5/8"	1 ¹ / ₂ "



SMALL OFFSET PULLS -
VARIOUS ENDS

Part	Dia.	Proj.
RM1530 (Flat)	5/8"	1 ⁷ / ₈ "
RM1570 (Round)	5/8"	1 ⁷ / ₈ "



PUSH BARS -
FLAT ENDS

Part	Dia.	Proj.
RM4002	1"	2 ³ / ₄ "
RM4012	1 ¹ / ₄ "	3"
RM4022	1 ¹ / ₂ "	3 ¹ / ₄ "



PUSH BARS -
ROUND ENDS

Part	Dia.	Proj.
RM4006	1"	2 ³ / ₄ "
RM4016	1 ¹ / ₄ "	3"
RM4026	1 ¹ / ₂ "	3 ¹ / ₄ "

Standard wood finish shown: Hickory, Sanded - Unfinished.

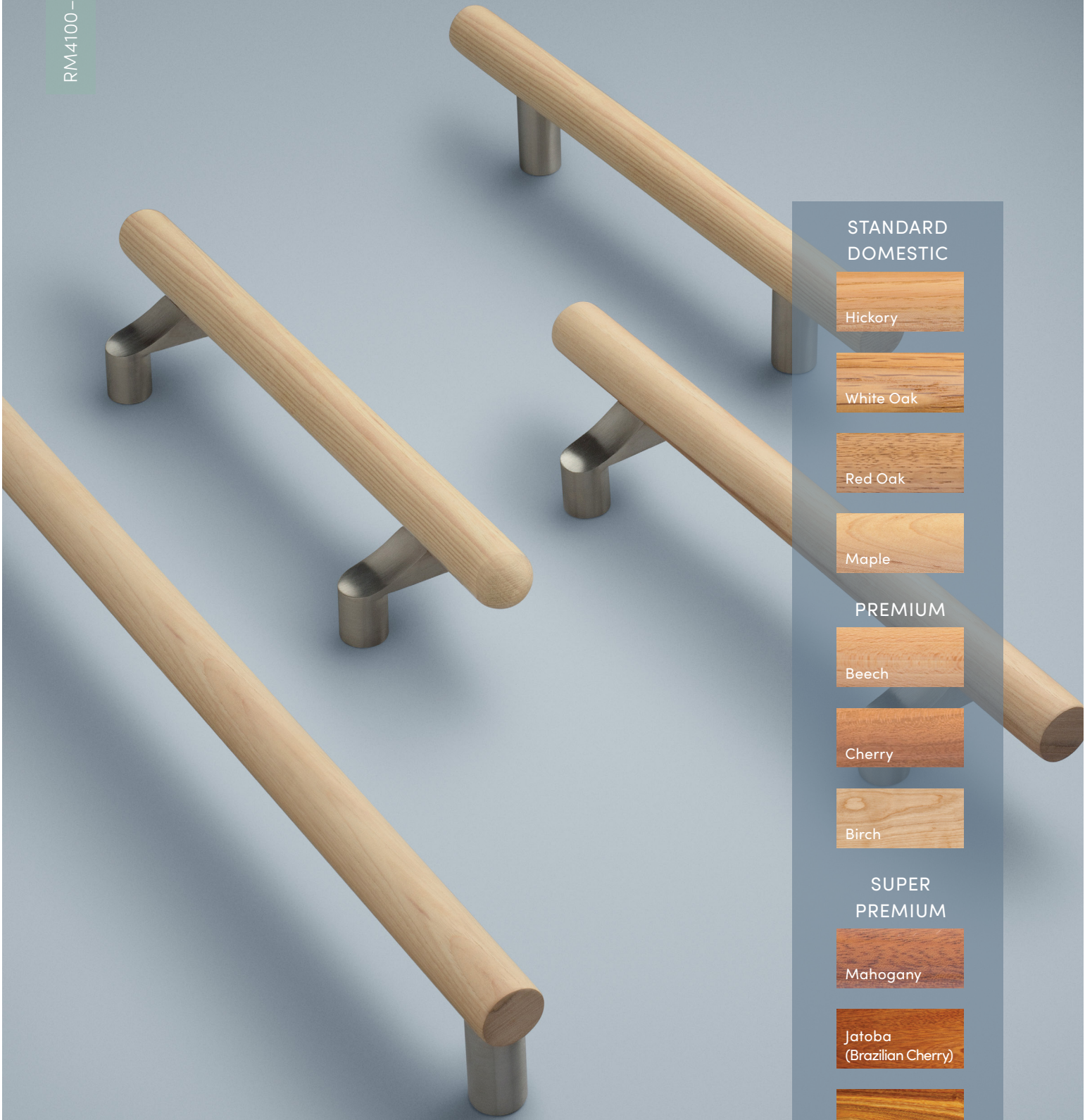

STANDARD
DOMESTIC



Hickory



White Oak



Red Oak



Maple

PREMIUM



Beech

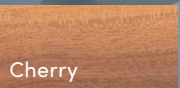

Cherry



Birch

SUPER
PREMIUM



Mahogany



Jatoba
(Brazilian Cherry)

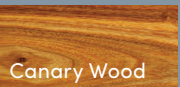

Canary Wood



Walnut

WOOD

ArborTek™

Full-length wood pulls and push bars pair with solid brass and stainless-steel mounting posts to create an expression of pure elegance.



STRAIGHT PULLS -
FLAT ENDS

Part	Dia.	Proj.
RM4100	1"	2 ³ / ₄ "
RM4110	1 ¹ / ₄ "	3"
RM4120	1 ¹ / ₂ "	3 ¹ / ₄ "



OFFSET PULLS -
FLAT ENDS

Part	Dia.	Proj.
RM4130	1"	2 ¹ / ₂ "
RM4140	1 ¹ / ₄ "	2 ³ / ₄ "
RM4150	1 ¹ / ₂ "	3"



STRAIGHT PULLS -
ROUND ENDS

Part	Dia.	Proj.
RM4104	1"	2 ³ / ₄ "
RM4114	1 ¹ / ₄ "	3"
RM4124	1 ¹ / ₂ "	3 ¹ / ₄ "



OFFSET PULLS -
ROUND ENDS

Part	Dia.	Proj.
RM4134	1"	2 ¹ / ₂ "
RM4144	1 ¹ / ₄ "	2 ³ / ₄ "
RM4154	1 ¹ / ₂ "	3"



PUSH BARS -
FLAT ENDS

Part	Dia.	Proj.
RM4112	1 ¹ / ₄ "	3"
RM4122	1 ¹ / ₂ "	3 ¹ / ₄ "



PUSH BARS -
ROUND ENDS

Part	Dia.	Proj.
RM4116	1 ¹ / ₄ "	3"
RM4126	1 ¹ / ₂ "	3 ¹ / ₄ "

Standard wood finish shown: Hickory, Sanded - Unfinished.

RM4160 - RM4190



WOOD

ArborTek™ with Collars

Add contrasting metal collars to your ArborTek pull to create a distinctive, unique look.



STRAIGHT PULLS - FLAT ENDS

Part	Dia.	Proj.
RM4160	1"	2 ³ / ₄ "
RM4170	1 ¹ / ₄ "	3"



OFFSET PULLS - FLAT ENDS

Part	Dia.	Proj.
RM4180	1"	2 ¹ / ₂ "
RM4190	1 ¹ / ₄ "	2 ⁷ / ₈ "

WOOD SPECIES

Standard Domestic		Premium	Super Premium		
Hickory		Beech		Mahogany	
White Oak		Cherry		Jatoba (Brazilian Cherry)	
Red Oak		Birch		Canary Wood	
Maple				Walnut	

RM4118 - RM4148



WOOD

ArborTek™ with Leather

Add either English Bridle or Upholstery Leather to your ArborTek pull to create a sophisticated look.



STRAIGHT PULLS -
FLAT ENDS

Part	Dia.	Proj.
RM4118	1¼"	3"







OFFSET PULLS -
FLAT ENDS

Part	Dia.	Proj.
RM4148	1¼"	3"

WOOD SPECIES

Standard Domestic		Premium	Super Premium		
Hickory		Beech		Mahogany	
White Oak		Cherry		Jatoba (Brazilian Cherry)	
Red Oak		Birch		Canary Wood	
Maple				Walnut	

ENGLISH BRIDLE LEATHER

B-LBRN Light Brown		B-BUR Burgundy	
B-MBRN Medium Brown		B-DBRN Dark Brown	
B-BLK Black			

RM2510 - RM2544



SANTOPRENE

SoftMet™

Durable, weather-resistant, Santoprene™ grips locked between solid metal, offer comfort and durability in a variety of architectural finishes and styles.



STRAIGHT PULLS -
FLAT ENDS

Part	Dia.	Proj.
RM2510	1 1/4"	3"



OFFSET PULLS -
FLAT ENDS

Part	Dia.	Proj.
RM2540	1 1/4"	2 3/4"



STRAIGHT PULLS -
ROUND ENDS

Part	Dia.	Proj.
RM2514	1 1/4"	3"



OFFSET PULLS -
ROUND ENDS

Part	Dia.	Proj.
RM2544	1 1/4"	2 3/4"



PUSH BARS -
FLAT ENDS

Part	Dia.	Proj.
RM2512	1 1/4"	3"



OFFSET PULLS

Part	Dia.	Proj.
RM2570	1 1/4"	2 23/32"



PUSH BARS -
ROUND ENDS

Part	Dia.	Proj.
RM2516	1 1/4"	3"

RM2610-RM2640

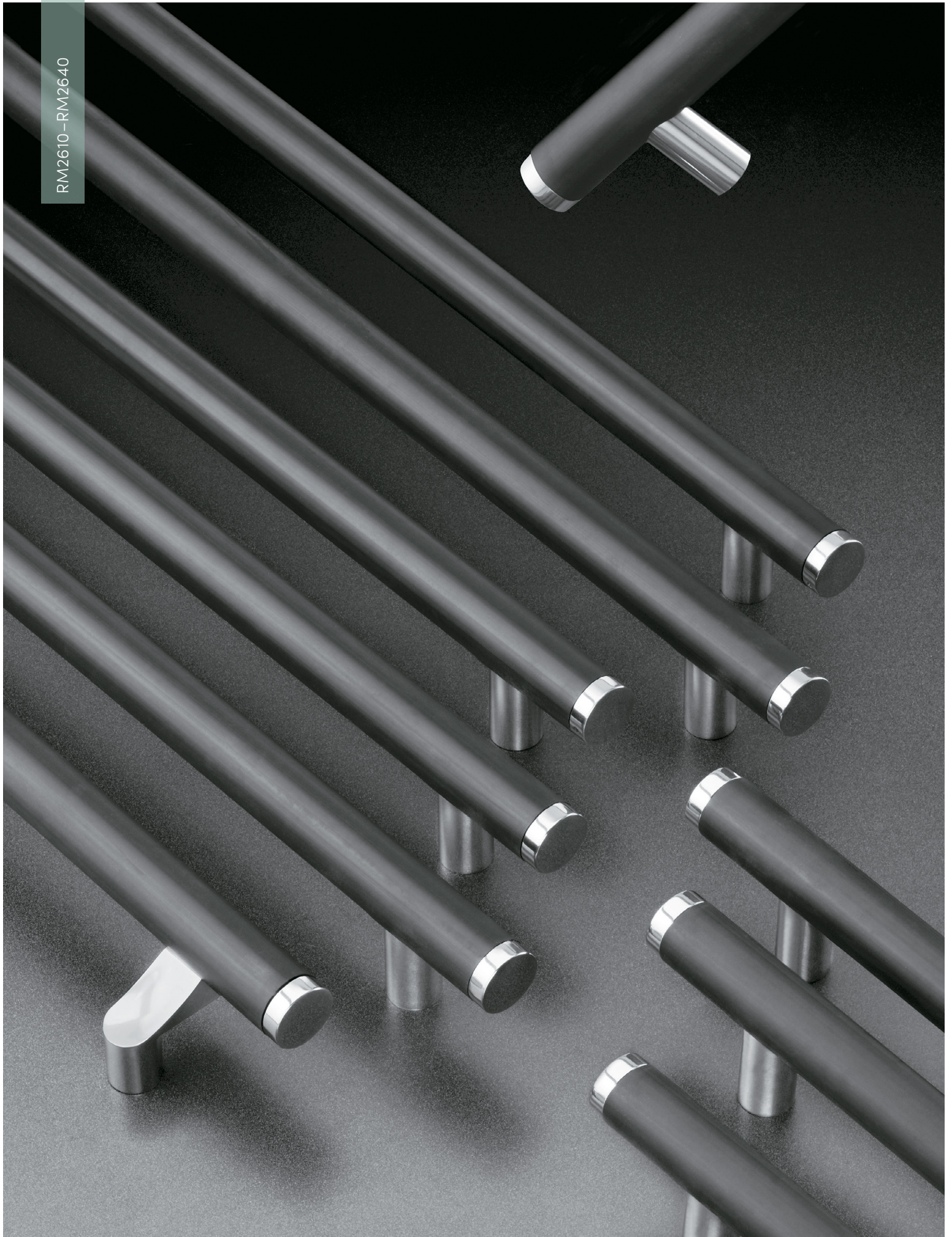

SANTOPRENE

SoftTek™

Extend your grip with a full-length application of Santoprene™. These pulls provide the ultimate in durable, weather-resistant gripping surfaces.



STRAIGHT PULLS -
FLAT ENDS

Part	Dia.	Proj.
RM2610	1¼"	3"



OFFSET PULLS -
FLAT ENDS

Part	Dia.	Proj.
RM2640	1¼"	2¾"



PUSH BARS - FLAT ENDS

Part	Dia.	Proj.
RM2612	1¼"	3"

RM3800 – RM3854
RM1410 – RM1470



BLACK ANODIZED

NoirMet™

Make a bold statement with the subtlety of black, hard-coat anodized grips contrasted with a compelling selection of end and mounting post finishes.



STRAIGHT PULLS -
FLAT ENDS

Part	Dia.	Proj.
RM3800	1"	2 ³ / ₄ "
RM3810	1 ¹ / ₄ "	3"
RM3820	1 ¹ / ₂ "	3 ¹ / ₄ "



STRAIGHT PULLS -
ROUND ENDS

Part	Dia.	Proj.
RM3804	1"	2 ³ / ₄ "
RM3814	1 ¹ / ₄ "	3"
RM3824	1 ¹ / ₂ "	3 ¹ / ₄ "



RM1410



RM1450

SMALL STRAIGHT PULLS -
VARIOUS ENDS

Part	Dia.	Proj.
RM1410 (Flat)	5/8"	1 ¹ / ₂ "
RM1450 (Round)	5/8"	1 ¹ / ₂ "



OFFSET PULLS -
FLAT ENDS

Part	Dia.	Proj.
RM3830	1"	2 ¹ / ₂ "
RM3840	1 ¹ / ₄ "	2 ³ / ₄ "
RM3850	1 ¹ / ₂ "	3"



OFFSET PULLS -
ROUND ENDS

Part	Dia.	Proj.
RM3834	1"	2 ¹ / ₂ "
RM3844	1 ¹ / ₄ "	2 ³ / ₄ "
RM3854	1 ¹ / ₂ "	3"



RM1430



RM1470

SMALL OFFSET PULLS -
VARIOUS ENDS

Part	Dia.	Proj.
RM1430 (Flat)	5/8"	1 ⁷ / ₈ "
RM1470 (Round)	5/8"	1 ⁷ / ₈ "



PUSH BARS - FLAT ENDS

Part	Dia.	Proj.
RM3802	1"	2 ³ / ₄ "
RM3812	1 ¹ / ₄ "	3"
RM3822	1 ¹ / ₂ "	3 ¹ / ₄ "



PUSH BARS - ROUND ENDS

Part	Dia.	Proj.
RM3806	1"	2 ³ / ₄ "
RM3816	1 ¹ / ₄ "	3"
RM3826	1 ¹ / ₂ "	3 ¹ / ₄ "

RM3900 - RM3954

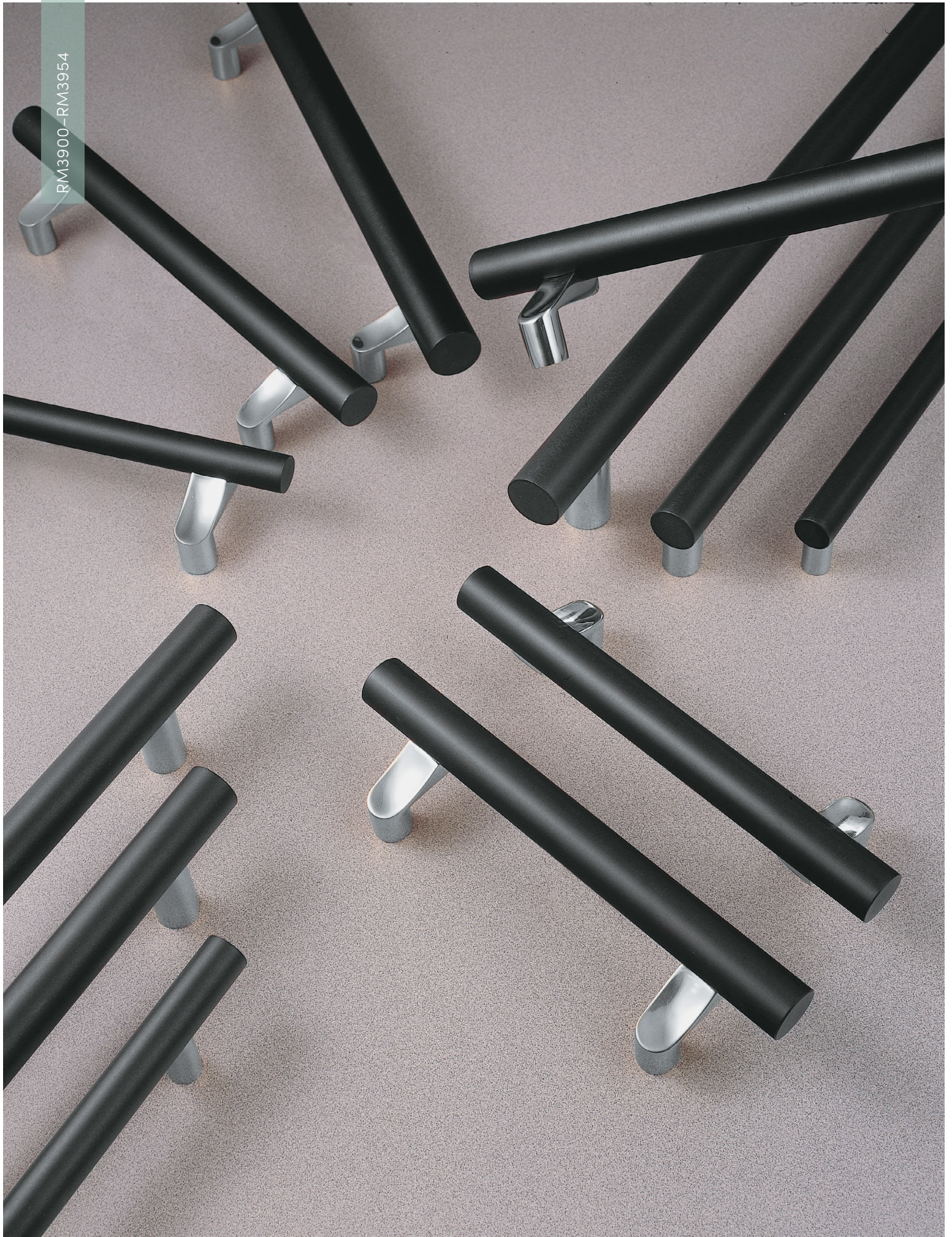

BLACK ANODIZED

NoirTek™

These full-length, black, hard-coat anodized grip pulls make an appealing statement of their own. The muted luster of black satin complements any setting and provides an atmosphere of relaxed sophistication.



STRAIGHT PULLS -
FLAT ENDS

Part	Dia.	Proj.
RM3900	1"	2 ³ / ₄ "
RM3910	1 ¹ / ₄ "	3"
RM3920	1 ¹ / ₂ "	3 ¹ / ₄ "

†Can be configured with a hands-free option



OFFSET PULLS -
FLAT ENDS

Part	Dia.	Proj.
RM3930	1"	2 ¹ / ₂ "
RM3940	1 ¹ / ₄ "	2 ³ / ₄ "
RM3950	1 ¹ / ₂ "	3"



STRAIGHT PULLS -
ROUND ENDS

Part	Dia.	Proj.
RM3904	1"	2 ³ / ₄ "
RM3914	1 ¹ / ₄ "	3"
RM3924	1 ¹ / ₂ "	3 ¹ / ₄ "

†Can be configured with a hands-free option



OFFSET PULLS -
ROUND ENDS

Part	Dia.	Proj.
RM3934	1"	2 ¹ / ₂ "
RM3944	1 ¹ / ₄ "	2 ³ / ₄ "
RM3954	1 ¹ / ₂ "	3"



PUSH BARS -
FLAT ENDS

Part	Dia.	Proj.
RM3902	1"	2 ³ / ₄ "
RM3912	1 ¹ / ₄ "	3"
RM3922	1 ¹ / ₂ "	3 ¹ / ₄ "



PUSH BARS -
ROUND ENDS

Part	Dia.	Proj.
RM3906	1"	2 ³ / ₄ "
RM3916	1 ¹ / ₄ "	3"
RM3926	1 ¹ / ₂ "	3 ¹ / ₄ "

RM3701 - RM3782
 RM3512 - RM3626

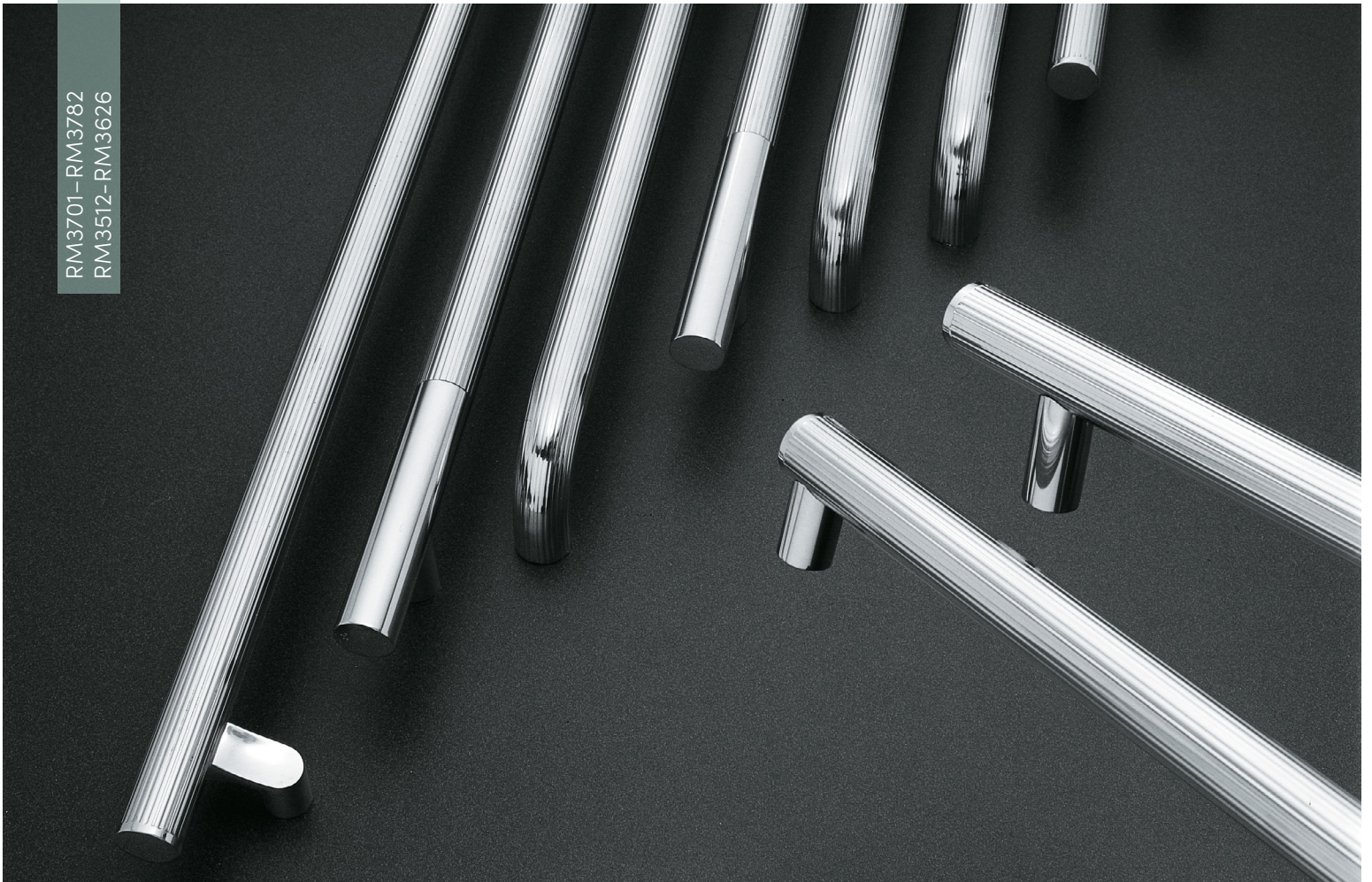

LineaMax™

Create a beautiful, fully-grooved, long door pull or add an element of interest using solid, smooth ends.



PUSH BARS - SOLID FLAT ENDS

Part	Dia.	Proj.
RM3512	1¼"	3"
RM3522	1½"	3¼"



PUSH BARS - FULLY GROOVED FLAT ENDS

Part	Dia.	Proj.
RM3612	1¼"	3"
RM3622	1½"	3¼"



PUSH BARS - SOLID ROUND ENDS

Part	Dia.	Proj.
RM3516	1¼"	3"
RM3526	1½"	3¼"



PUSH BARS - FULLY GROOVED ROUND ENDS

Part	Dia.	Proj.
RM3616	1¼"	3"
RM3626	1½"	3¼"

GROOVED

LineaMax™ (continued)



STRAIGHT PULLS - SOLID FLAT ENDS

Part	Dia.	Proj.
RM3701	1¼"	3"
RM3702	1½"	3¼"



STRAIGHT PULLS - FULLY GROOVED FLAT ENDS

Part	Dia.	Proj.
RM3721	1¼"	3"
RM3722	1½"	3¼"



STRAIGHT PULLS - SOLID ROUND ENDS

Part	Dia.	Proj.
RM3751	1¼"	3"
RM3752	1½"	3¼"



STRAIGHT PULLS - FULLY GROOVED ROUND ENDS

Part	Dia.	Proj.
RM3771	1¼"	3"
RM3772	1½"	3¼"



STRAIGHT PULLS - FULLY GROOVED BENT ENDS

Part	Dia.	Proj.
RM3741	1¼"	3"
RM3742	1½"	3½"



OFFSET PULLS - SOLID FLAT ENDS

Part	Dia.	Proj.
RM3711	1¼"	2¾"
RM3712	1½"	3"



OFFSET PULLS - FULLY GROOVED FLAT ENDS

Part	Dia.	Proj.
RM3731	1¼"	2¾"
RM3732	1½"	3"



OFFSET PULLS - SOLID ROUND ENDS

Part	Dia.	Proj.
RM3761	1¼"	2¾"
RM3762	1½"	3"



OFFSET PULLS - FULLY GROOVED ROUND ENDS

Part	Dia.	Proj.
RM3781	1¼"	2½"
RM3782	1½"	3"

RM3101, RM3131
RM1211



GROOVED

Groove

Get your groove on. The machined bands at both ends of these post mount pulls provide an added level of sophistication.



STRAIGHT PULLS -
FLAT END

Part	Dia.	Proj.
RM3101	1"	2 ³ / ₄ "



OFFSET PULLS -
FLAT END

Part	Dia.	Proj.
RM3131	1"	2 ¹ / ₂ "



SMALL STRAIGHT PULLS -
FLAT END

Part	Dia.	Proj.
RM1211	5/8"	1 ¹ / ₂ "

RM3102 - RM3126, RM3300 - RM3342,
RM1200 - RM1270

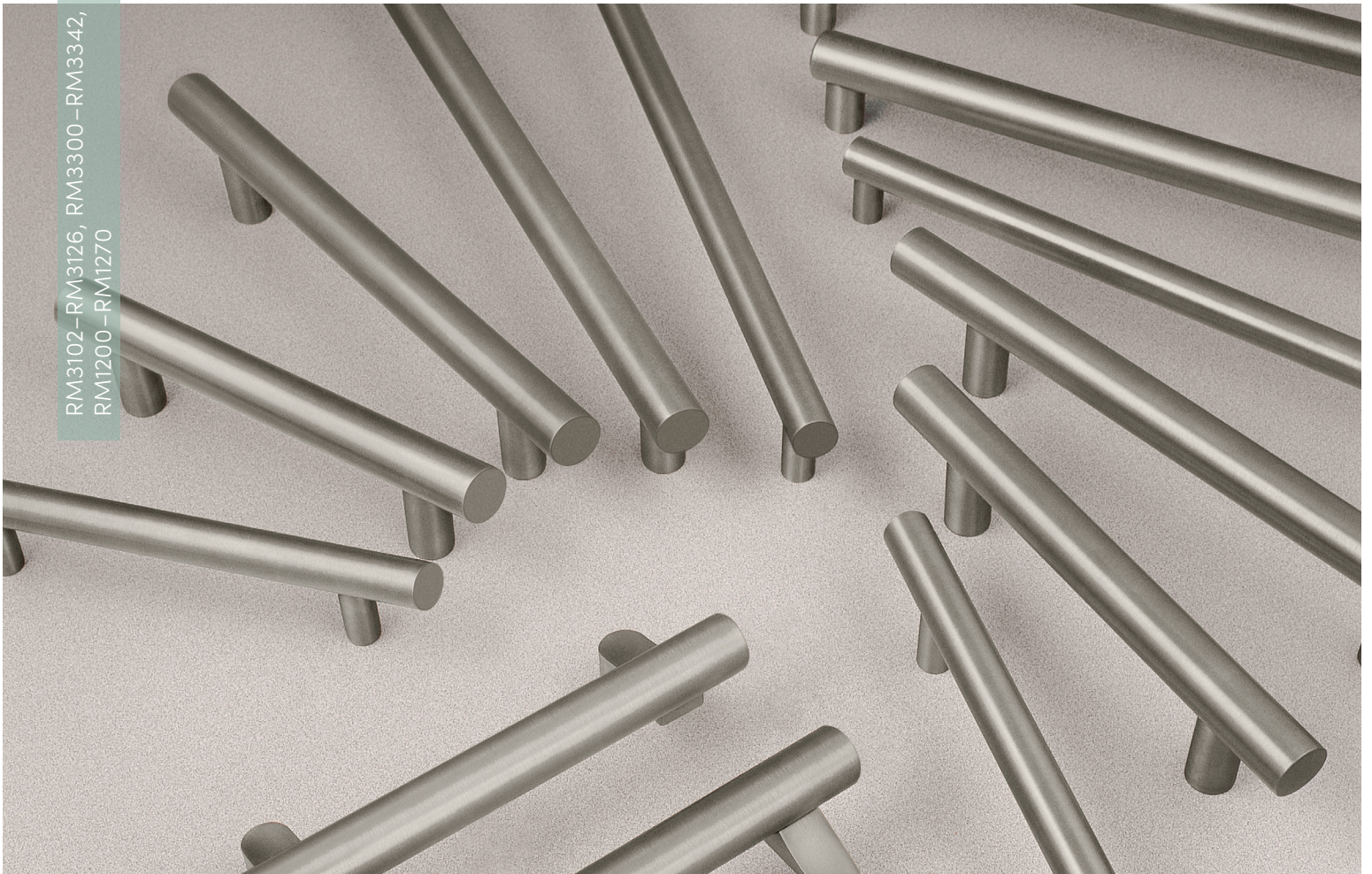

SMOOTH

MegaTek™

Effortless style in a simple design allow these pulls to offer a pleasing, functional, modern solution to any entry door.



STRAIGHT PULLS - FLAT ENDS

Part	Dia.	Proj.
RM3300	1"	2 ³ / ₄ "
RM3301*	1 ¹ / ₄ "	3"
RM3302	1 ¹ / ₂ "	3 ¹ / ₄ "

* For locking pull options, see page 105.



* Can be configured with a hands-free option.

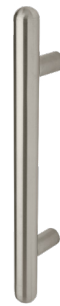

STRAIGHT PULLS - ROUND ENDS

Part	Dia.	Proj.
RM3320	1"	2 ³ / ₄ "
RM3321	1 ¹ / ₄ "	3"
RM3322	1 ¹ / ₂ "	3 ¹ / ₄ "

Can be configured with a hands-free option.



SMOOTH

MegaTek™ (continued)



STRAIGHT PULLS -
BENT ENDS

Part	Dia.	Proj.
RM3340	1"	3"
RM3341	1¼"	3"
RM3342	1½"	3½"



SMALL STRAIGHT PULLS -
FLAT ENDS

Part	Dia.	Proj.
RM1200	½"	1⅜"
RM1210	⅝"	1½"



SMALL STRAIGHT PULLS -
ROUND ENDS

Part	Dia.	Proj.
RM1240	½"	1⅜"
RM1250	⅝"	1½"



PUSH BARS -
FLAT ENDS

Part	Dia.	Proj.
RM3102	1"	2¾"
RM3112	1¼"	3"
RM3122	1½"	3¼"



OFFSET PULLS -
FLAT ENDS

Part	Dia.	Proj.
RM3310	1"	2½"
RM3311	1¼"	2¾"
RM3312	1½"	3"



OFFSET PULLS -
ROUND ENDS

Part	Dia.	Proj.
RM3330	1"	2½"
RM3331	1¼"	2¾"
RM3332	1½"	3"



SMALL OFFSET PULLS -
FLAT ENDS

Part	Dia.	Proj.
RM1230	⅝"	1⅞"



SMALL OFFSET PULLS -
ROUND ENDS

Part	Dia.	Proj.
RM1270	⅝"	1⅞"



PUSH BARS -
ROUND ENDS

Part	Dia.	Proj.
RM3106	1"	2¾"
RM3116	1¼"	3"
RM3126	1½"	3¼"

RM3400 - RM3442
RM3202 - RM3226
RM1300 - RM1370



SMOOTH

NeoMax™

These post-mounted pulls feature a durable and attractive GripZone finish over a smooth, contemporary base style.



STRAIGHT PULLS -
FLAT ENDS

Part	Dia.	Proj.
RM3400	1"	2 ³ / ₄ "
RM3401*	1 ¹ / ₄ "	3"
RM3402	1 ¹ / ₂ "	3 ¹ / ₄ "

† For locking pull options, see page 105.



STRAIGHT PULLS -
ROUND ENDS

Part	Dia.	Proj.
RM3420	1"	2 ³ / ₄ "
RM3421	1 ¹ / ₄ "	3"
RM3422	1 ¹ / ₂ "	3 ¹ / ₄ "



STRAIGHT PULLS -
BENT ENDS

Part	Dia.	Proj.
RM3440	1"	3"
RM3441	1 ¹ / ₄ "	3"
RM3442	1 ¹ / ₂ "	3 ¹ / ₂ "



PUSH BARS WITH
GRIPZONE - FLAT ENDS

Part	Dia.	Proj.
RM3202	1"	2 ³ / ₄ "
RM3212	1 ¹ / ₄ "	3"
RM3222	1 ¹ / ₂ "	3 ¹ / ₄ "



OFFSET PULLS -
FLAT ENDS

Part	Dia.	Proj.
RM3410	1"	2 ¹ / ₂ "
RM3411	1 ¹ / ₄ "	2 ³ / ₄ "
RM3412	1 ¹ / ₂ "	3"



OFFSET PULLS -
ROUND ENDS

Part	Dia.	Proj.
RM3430	1"	2 ¹ / ₂ "
RM3431	1 ¹ / ₄ "	2 ³ / ₄ "
RM3432	1 ¹ / ₂ "	3"



PUSH BARS WITH
GRIPZONE - ROUND ENDS

Part	Dia.	Proj.
RM3206	1"	2 ³ / ₄ "
RM3216	1 ¹ / ₄ "	3"
RM3226	1 ¹ / ₂ "	3 ¹ / ₄ "



RM1300



RM1340

SMALL STRAIGHT PULLS -
VARIOUS ENDS

Part	Dia.	Proj.
RM1300 (Flat)	1/2"	1 ³ / ₈ "
RM1310 (Flat)	5/8"	1 ¹ / ₂ "
RM1340 (Round)	1/2"	1 ³ / ₈ "
RM1350 (Round)	5/8"	1 ¹ / ₂ "



RM1330



RM1370

SMALL OFFSET PULLS -
VARIOUS ENDS

Part	Dia.	Proj.
RM1330 (Flat)	5/8"	1 ⁷ / ₈ "
RM1370 (Round)	5/8"	1 ⁷ / ₈ "

RM3010 - RM3060



SMOOTH

NeoMetrix™

The satin finish of the GripZone area against a bright finish provides a practical solution to extending the life of your door pull or push bar by concealing the minor marks and scratches of everyday use.



STRAIGHT PULLS -
BENT ENDS

Part	Dia.	Proj.
RM3010	1"	3½"
RM3020	1¼"	3"
RM3030	1½"	3½"



OFFSET PULLS -
BENT ENDS

Part	Dia.	Proj.
RM3040	1"	3½"
RM3050	1¼"	3"
RM3060	1½"	3½"



PUSH BARS WITH
GRIPZONE - BENT ENDS

Part	Dia.	Proj.
RM3012	1"	2½"
RM3022	1¼"	3"
RM3032	1½"	3½"

RM7300 - RM7450

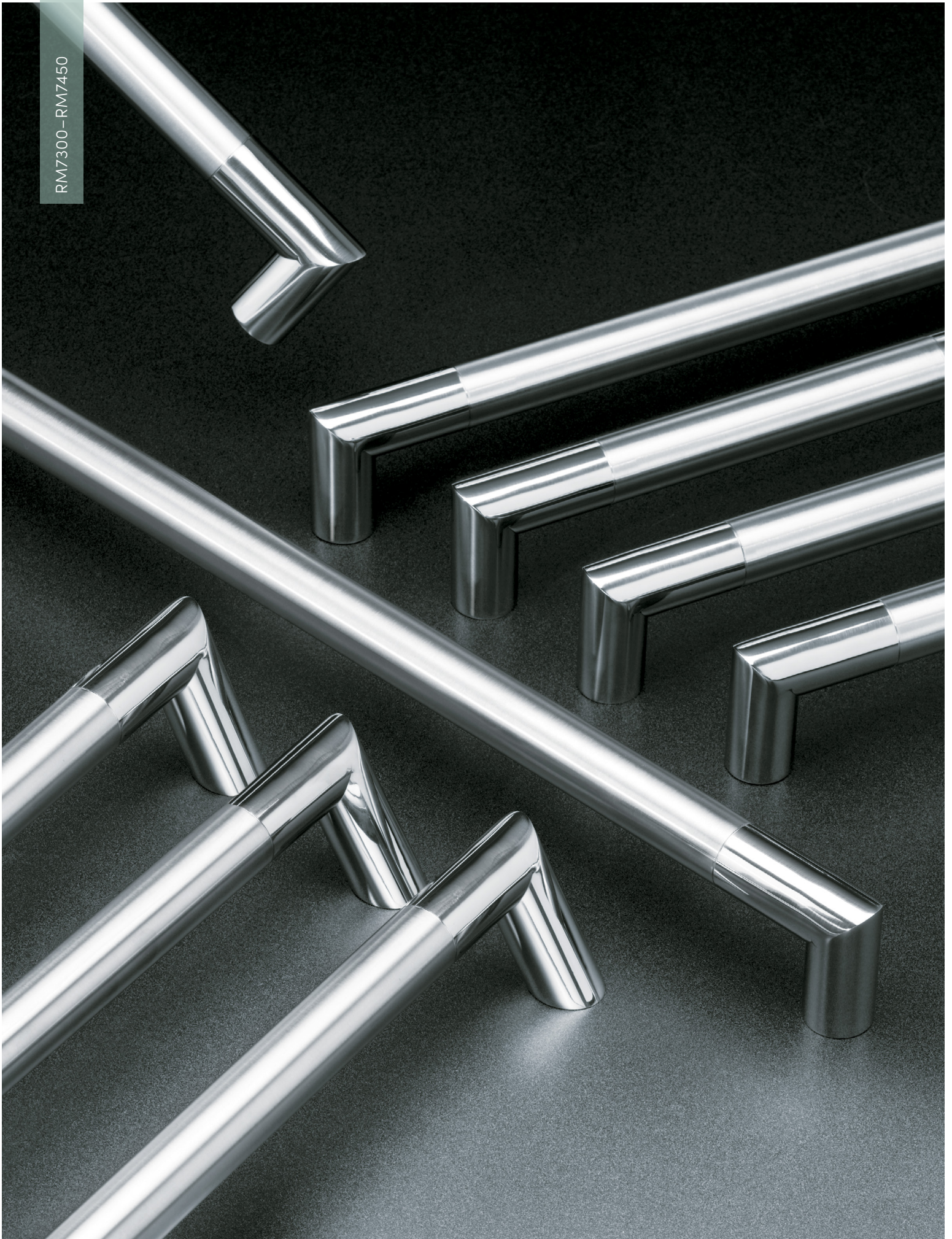

SMOOTH

NeoMitre™

Combine the attractive, concealing aspects of the GripZone finish with a precise fabrication process that smooths the joints of this mitre pull.



STRAIGHT PULLS WITHOUT GRIPZONE

Part	Dia.	Proj.
RM7300	1"	2¾"
RM7310	1¼"	3"
RM7320	1½"	3¼"



OFFSET PULLS WITHOUT GRIPZONE

Part	Dia.	Proj.
RM7330	1"	2¾"
RM7340	1¼"	3"
RM7350	1½"	3¼"



STRAIGHT PULLS WITH GRIPZONE

Part	Dia.	Proj.
RM7400	1"	2¾"
RM7410	1¼"	3"
RM7420	1½"	3¼"



OFFSET PULLS WITH GRIPZONE

Part	Dia.	Proj.
RM7430	1"	2¾"
RM7440	1¼"	3"
RM7450	1½"	3¼"



SMALL STRAIGHT PULL

Part	Dia.	Proj.
RM1665	½"	1-¾"
RM1675	¾"	2-½"



PUSH BARS WITHOUT GRIPZONE

Part	Dia.	Proj.
RM7302	1"	2½"
RM7312	1¼"	3"
RM7322	1½"	3"



PUSH BARS WITH GRIPZONE

Part	Dia.	Proj.
RM7402	1"	2½"
RM7412	1¼"	3"
RM7422	1½"	3"

RM7210 - RM7240

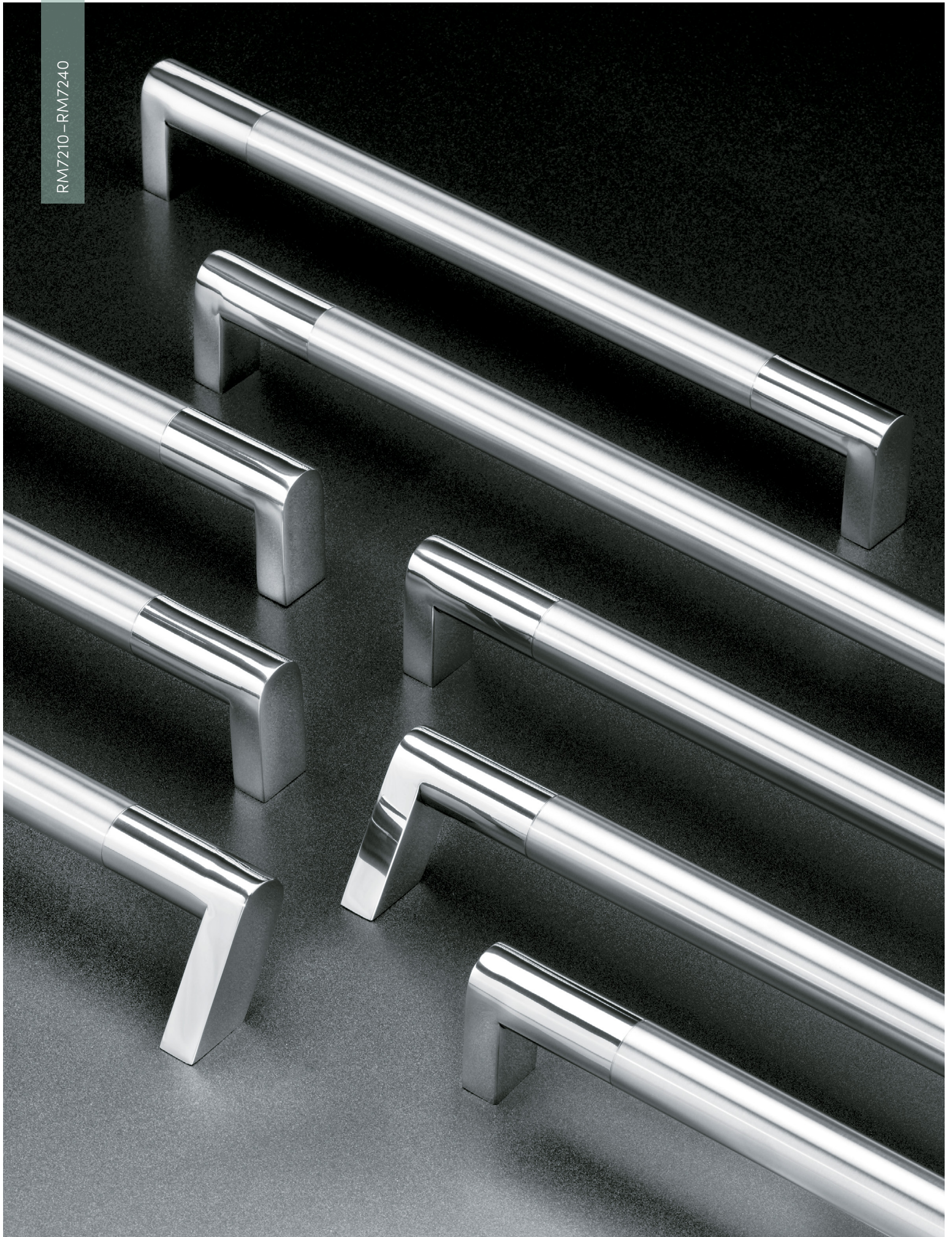

SMOOTH

NeoCylinder™

Mesmerizing style fashioned from the seamless blending of a cylinder pull combined with flat end posts. Achieve pure captivation with the addition of the GripZone finish as contrast.



RM7101 RM7210

STRAIGHT PULL WITHOUT GRIPZONE

Part	Dia.	Proj.
RM7210	1 1/4"	2 3/4"
RM7101	1 1/4"	3"



OFFSET PULL WITHOUT GRIPZONE

Part	Dia.	Proj.
RM7220	1 1/4"	2 3/4"



STRAIGHT PULL WITH GRIPZONE

Part	Dia.	Proj.
RM7230	1 1/4"	2 3/4"



OFFSET PULL WITH GRIPZONE

Part	Dia.	Proj.
RM7240	1 1/4"	2 3/4"



PUSH BAR WITHOUT GRIPZONE

Part	Dia.	Proj.
RM7212	1 1/4"	2 3/4"



PUSH BAR WITH GRIPZONE

Part	Dia.	Proj.
RM7232	1 1/4"	2 3/4"

RM7501 - RM7511



KNURLED

Rockwood 75th Anniversary Collection

Textured design that produces a better gripping surface while enhancing the aesthetics of your door opening



STRAIGHT PULL –
FLAT END

Part	Dia.	Proj.
RM7501	1¼"	3"



OFFSET PULL –
FLAT END

Part	Dia.	Proj.
RM7511	1¼"	2¾"



STRAIGHT PULL –
ROUND END

Part	Dia.	Proj.
RM7521	1¼"	3"



OFFSET PULL –
ROUND END

Part	Dia.	Proj.
RM7531	1¼"	2¾"

FINISH OPTIONS*



- US4 grip, US3 ends/post



- 10BE grip, US10 ends/post



- 10BE grip, 10BE ends/post



- BSP grip, BSP ends/post



- US4 grip, BSP ends/post



- US32D grip, US32D ends/post



- WSP grip, US32 ends/post



- WSP grip, WSP ends/post



- BSP grip, US32 ends/post



- US32D grip, US10B ends/post



- BSP grip, US3 ends/post



- 10BE grip, US4 ends/post



Mid-Post Option

*For the complete list of finish combinations please visit our website

NOTE: Mid-post option available on all Knurled models (suffix MP)

RM4200 - RM4274

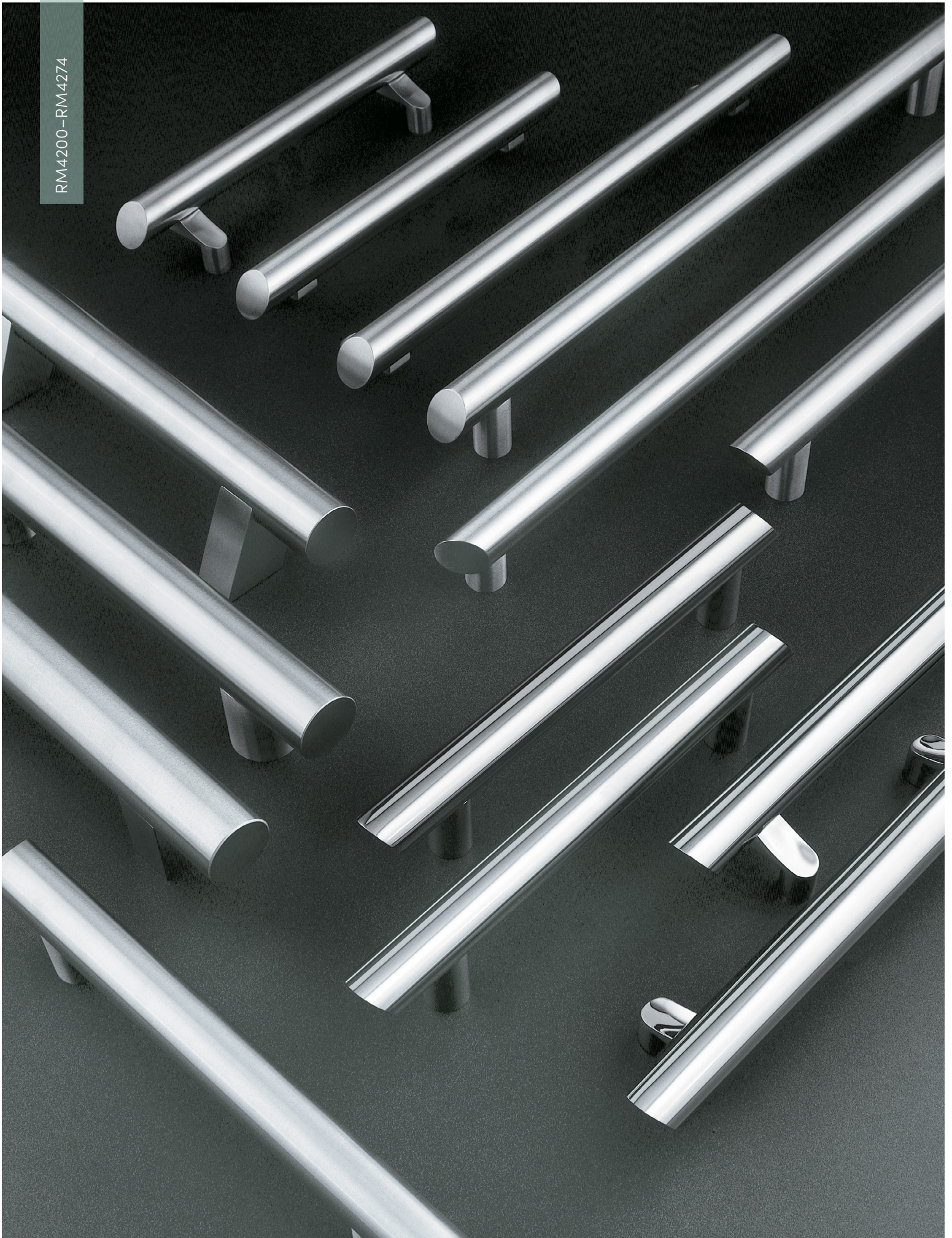

ACCENTS

SkewTek™

Angled ends coupled with a tubular design allow this made-to-order pull to be as unique and distinctive as your entrance.



STRAIGHT PULLS -
FORWARD SEGMENT

Part	Dia.	Proj.
RM4200	1½"	3¼"



OFFSET PULLS -
FORWARD SEGMENT

Part	Dia.	Proj.
RM4210LH	1½"	3"
RM4210RH	1½"	3"



STRAIGHT PULLS -
RECTANGULAR POSTS

Part	Dia.	Proj.
RM4270	2"	3¾"



OFFSET PULLS -
RECTANGULAR POSTS

Part	Dia.	Proj.
RM4272	2"	3¾"



STRAIGHT PULLS -
ROUND POSTS

Part	Dia.	Proj.
RM4274	2"	3¾"

RM4274



ACCENTS

SkewTek™

Angled ends coupled with a tubular design allow this made-to-order pull to be as unique and distinctive as your entrance.



STRAIGHT PULLS -
ROUND POSTS

Part	Grip Size	Proj.
RM4250	1" x 1¼"	2¾"



OFFSET PULLS -
ROUND POSTS

Part	Grip Size	Proj.
RM4252	1" x 1¼"	2½"



STRAIGHT PULLS -
ROUND MITERED POSTS

Part	Grip Size	Proj.
RM4255	1" x 1¼"	2¾"



OFFSET PULLS -
RECTANGULAR POSTS

Part	Grip Size	Proj.
RM4262	1" x 1¼"	2¾"



STRAIGHT PULLS -
RECTANGULAR POSTS

Part	Grip Size	Proj.
RM4260	1" x 1¼"	2¾"



STRAIGHT PULLS -
RECTANGULAR
MITERED POSTS

Part	Grip Size	Proj.
RM4265	1" x 1¼"	2¾"



OFFSET PULLS -
RECTANGULAR
MITERED POSTS

Part	Grip Size	Proj.
RM4267	1" x 1¼"	2¾"

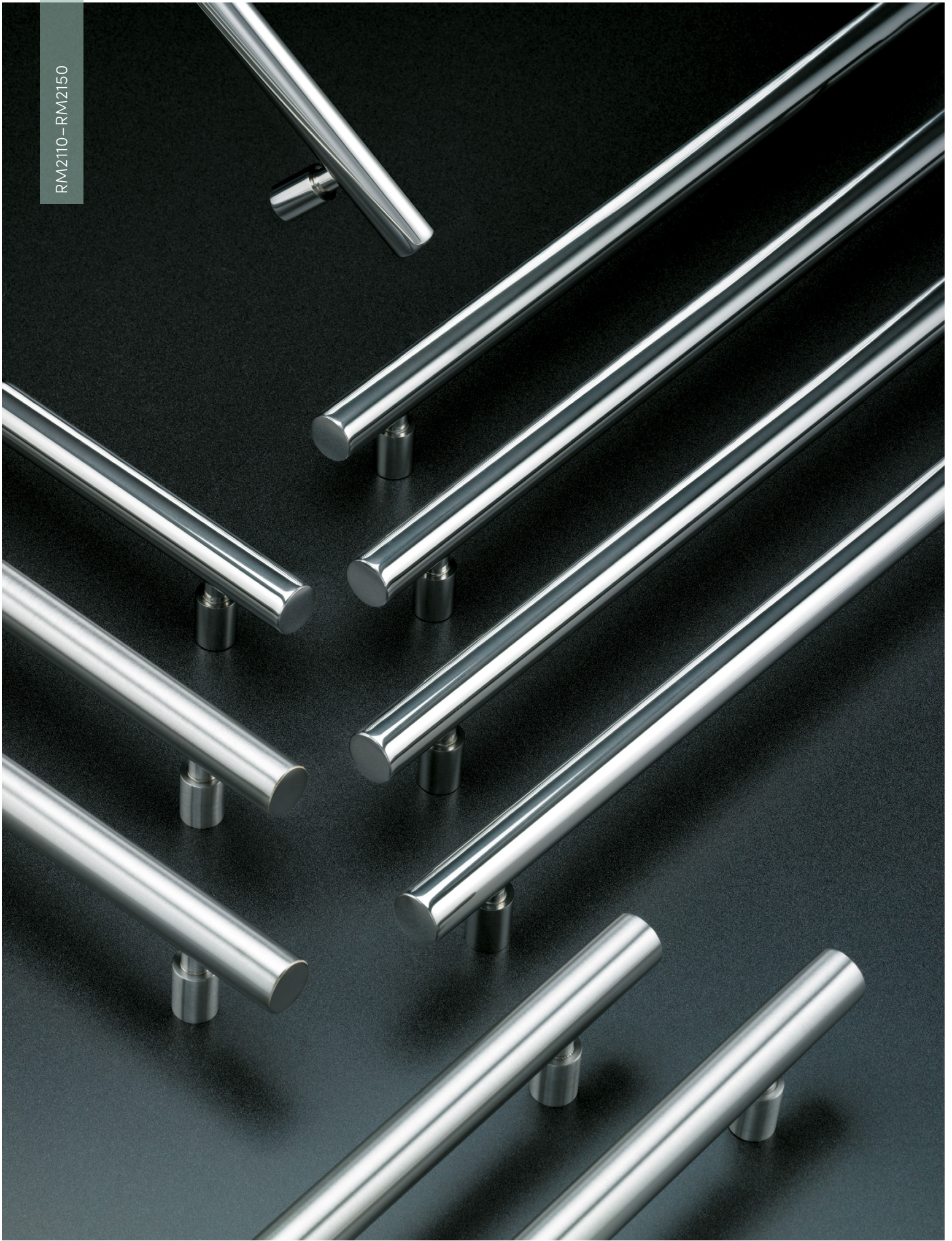

ACCENTS

MezzoTek™

Mounted on sturdy, necked posts, these pulls appear to float across your door. Choose a contrasting finish to bring an extra element of interest to an already unique style.



STRAIGHT PULLS WITHOUT GRIPZONE

Part	Dia.	Proj.
RM2110	1¼"	3"
RM2120	1½"	3¼"



STRAIGHT PULL WITH DOUBLE STEPPED POST

Part	Dia.	Proj.
RM2150	1"	2¾"



STRAIGHT PULLS WITH GRIPZONE

Part	Dia.	Proj.
RM2130	1¼"	3"
RM2140	1½"	3¼"



PUSH BARS WITHOUT GRIPZONE

Part	Dia.	Proj.
RM2112	1¼"	3"
RM2122	1½"	3¼"



PUSH BARS WITH GRIPZONE

Part	Dia.	Proj.
RM2132	1¼"	3"
RM2142	1½"	3¼"



ACCENTS

BandWidth™

Select from a variety of finishes, base metals, grip options, and end styles to find the perfect combination of color, contrast, and design.



STRAIGHT PULLS -
FLAT ENDS

Part	Dia.	Proj.
RM2200	1"	2 ³ / ₄ "
RM2210	1 ¹ / ₄ "	3"
RM2260	1 ¹ / ₄ "	3 ¹ / ₈ "



OFFSET PULLS -
FLAT ENDS

Part	Dia.	Proj.
RM2230	1"	2 ¹ / ₂ "
RM2240	1 ¹ / ₄ "	2 ⁷ / ₈ "
RM2290	1 ¹ / ₄ "	3 ¹ / ₈ "



STRAIGHT PULLS -
ROUND ENDS

Part	Dia.	Proj.
RM2204	1"	2 ³ / ₄ "
RM2214	1 ¹ / ₄ "	3"



OFFSET PULLS -
ROUND ENDS

Part	Dia.	Proj.
RM2234	1"	2 ¹ / ₂ "
RM2244	1 ¹ / ₄ "	2 ⁷ / ₈ "



PUSH BARS -
FLAT ENDS

Part	Dia.	Proj.
RM2202	1"	2 ³ / ₄ "
RM2212	1 ¹ / ₄ "	3"



PUSH BARS -
ROUND ENDS

Part	Dia.	Proj.
RM2206	1"	2 ³ / ₄ "
RM2216	1 ¹ / ₄ "	3"

Projection shown excludes collar thickness.

RM405 - RM423



RightAngles

Add symmetry to matching glass door exit devices with the usable, visually-appealing style of the horizontal and vertical sections found in these right-angle pulls and push bars.



ANGLED PULL

Part	Dia.	Proj.
RM405-15	1 1/4"	3"



ANGLED PULL WITH GRIPZONE

Part	Dia.	Proj.
RM415-15	1 1/4"	3"



SHORT ANGLED PUSH PULLS*

Part	Dia.	Proj.
RM410 (Leg Up)	1 1/4"	3"
RM411 (Leg Down)	1 1/4"	3"



SHORT ANGLED PUSH PULLS WITH GRIPZONE*

Part	Dia.	Proj.
RM420 (Leg Up)	1 1/4"	3"
RM421 (Leg Down)	1 1/4"	3"



LONG ANGLED PUSH PULLS*

Part	Dia.	Proj.
RM412 (Leg Up)	1 1/4"	3"
RM413 (Leg Down)	1 1/4"	3"



LONG ANGLED PUSH PULLS WITH GRIPZONE*

Part	Dia.	Proj.
RM422 (Leg Up)	1 1/4"	3"
RM423 (Leg Down)	1 1/4"	3"

* RM410–RM423 specify height X width.

RM201-RM372

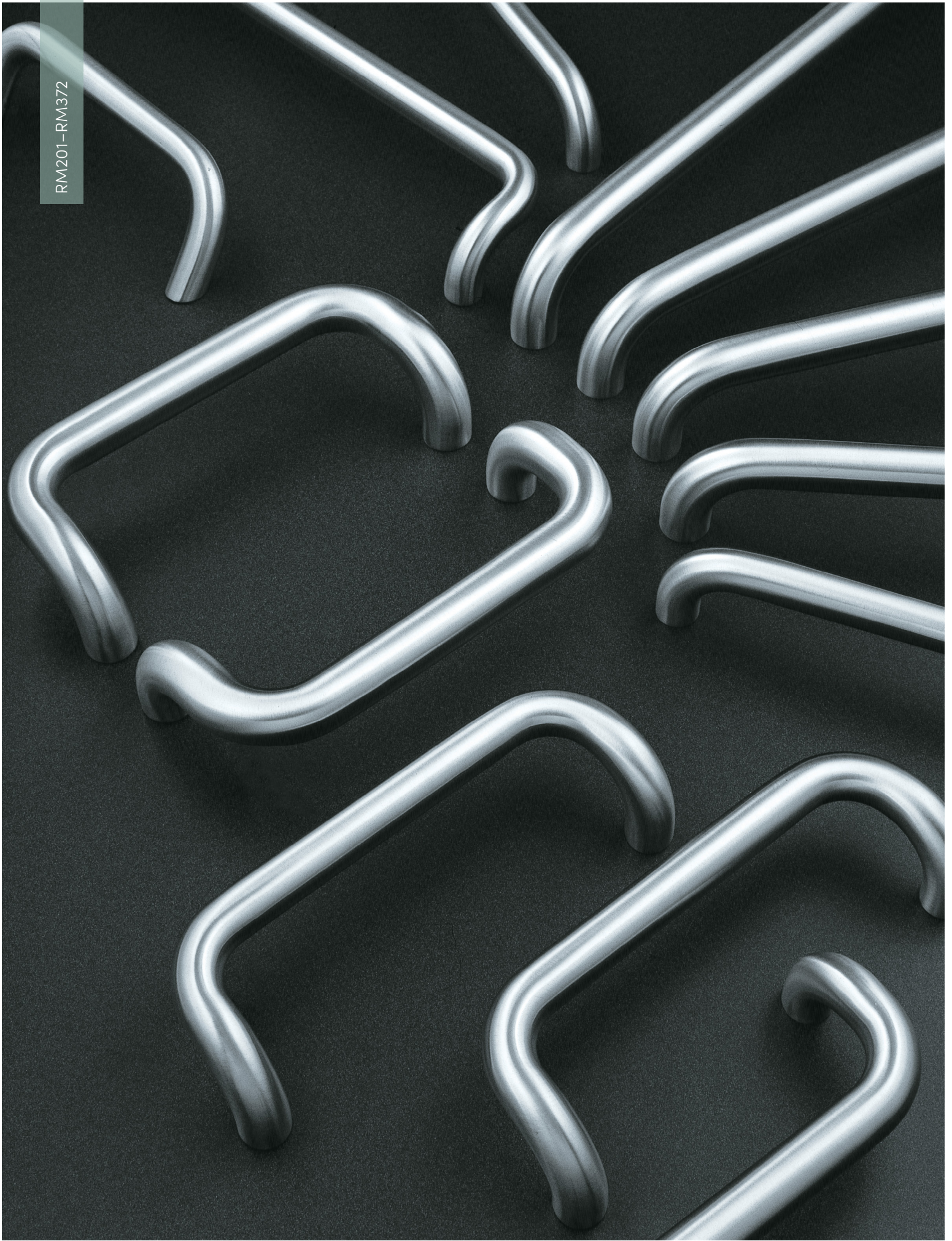

ESSENTIAL

Tubular

Rugged beauty describes these functional tubular pulls.



STRAIGHT PULLS - BENT ENDS

Part	Dia	CTC	Proj.
RM301	1/4"	12"	3"
RM302	1/4"	18"	3"
RM303	1/4"	24"	3"
RM304	1/4"	36"	3"
RM321	1/2"	12"	3 1/2"
RM322	1/2"	18"	3 1/2"
RM323	1/2"	24"	3 1/2"
RM324	1/2"	36"	3 1/2"



90° OFFSET PULLS - BENT ENDS

Part	Dia	CTC	Proj.
RM201	1/4"	12"	3"
RM202	1/4"	18"	3"
RM203	1/4"	24"	3"
RM204	1/4"	36"	3"
RM221	1/2"	12"	3 1/2"
RM222	1/2"	18"	3 1/2"
RM223	1/2"	24"	3 1/2"
RM224	1/2"	36"	3 1/2"

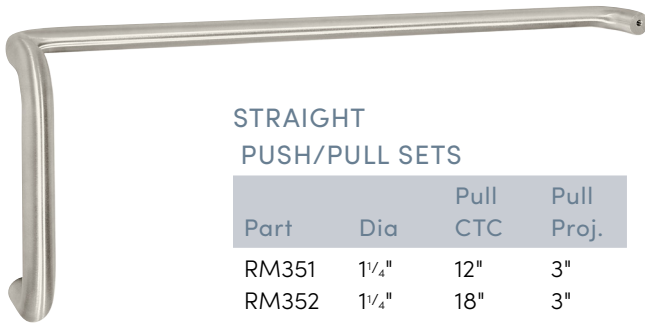

STRAIGHT PUSH/PULL SETS

Part	Dia	Pull CTC	Pull Proj.
RM351	1/4"	12"	3"
RM352	1/4"	18"	3"
RM371	1/2"	12"	3 1/2"
RM372	1/2"	18"	3 1/2"



HEAVY DUTY 30° OFFSET PULLS

Part	Dia	CTC	Proj.
RM257	1/4"	10"	3 3/4"
RM258	1/4"	12"	3 3/4"
RM259	1/4"	18"	3 3/4"



PUSH BARS

Part	Dia	Proj.
RM350	1/4"	3"
RM370	1/2"	3 1/2"

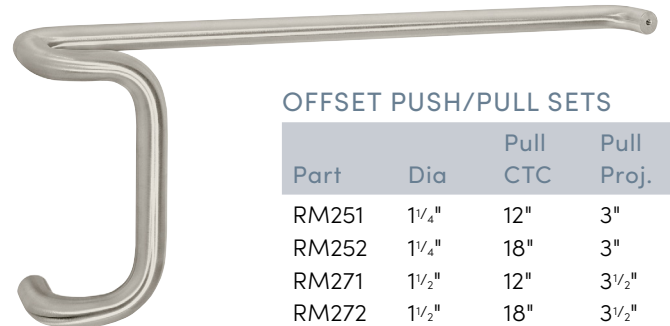

OFFSET PUSH/PULL SETS

Part	Dia	Pull CTC	Pull Proj.
RM251	1/4"	12"	3"
RM252	1/4"	18"	3"
RM271	1/2"	12"	3 1/2"
RM272	1/2"	18"	3 1/2"

110-BF169, 11047-BF15847,
47-PB-SP47



ESSENTIAL

Standard

When the project requires the benefit and beauty of a classic pull or push bar, these standard products fit the bill.



STRAIGHT PULLS

Part	CTC	Proj.
110-RKW	8"	3½"
111A	9"	3½"
111	10"	3½"
112	12"	3½"
118	18"	3½"

NOTE: Pull projection is 3½" for stainless steel and 3" for aluminum, brass, and bronze.



90° OFFSET PULLS

Part	CTC	Proj.
BF156	8"	3½"
BF157A	9"	3½"
BF157	10"	3½"
BF158	12"	3½"
BF159	18"	3½"

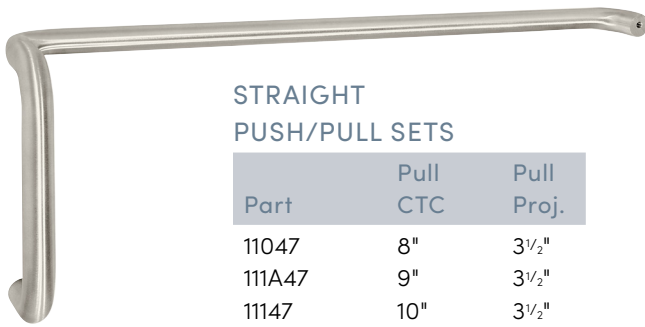

STRAIGHT PUSH/PULL SETS

Part	Pull CTC	Pull Proj.
11047	8"	3½"
111A47	9"	3½"
11147	10"	3½"
11247	12"	3½"
11847	18"	3½"

NOTE: Pull projection is 3½" for stainless steel and 3" for aluminum, brass, and bronze.



45° OFFSET PULLS

Part	CTC	Proj.
BF166	8"	3½"
BF167A	9"	3½"
BF167	10"	3½"
BF168	12"	3½"
BF169	18"	3½"



PUSH BARS

Part	Base Plate	Proj.
47-PB	No	2¾"
BP47	Yes	2⅞"

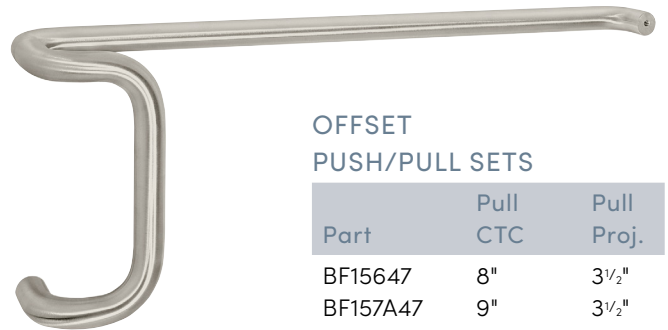

OFFSET PUSH/PULL SETS

Part	Pull CTC	Pull Proj.
BF15647	8"	3½"
BF157A47	9"	3½"
BF15747	10"	3½"
BF15847	12"	3½"



SINGLE PROJECTION PUSH BAR

Part	Proj.
SP47	2¾"

(For pricing refer to the Rockwood Products Accessories Price Book)

Standard with Santoprene

Extend your grip with an application of Santoprene™. These pulls provide the ultimate in durable, weather-resistant gripping surfaces.



STRAIGHT PULL

Part	Dia.	CTC	Proj.
190	1"	12"	3"



90° OFFSET PULL

Part	Dia.	CTC	Proj.
BF195	1"	18"	3-1/2"

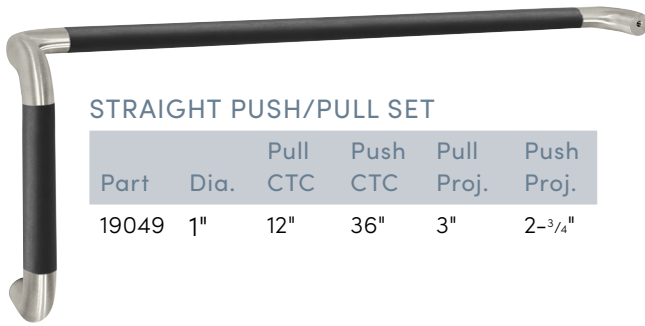

STRAIGHT PUSH/PULL SET

Part	Dia.	Pull CTC	Push CTC	Pull Proj.	Push Proj.
19049	1"	12"	36"	3"	2-3/4"

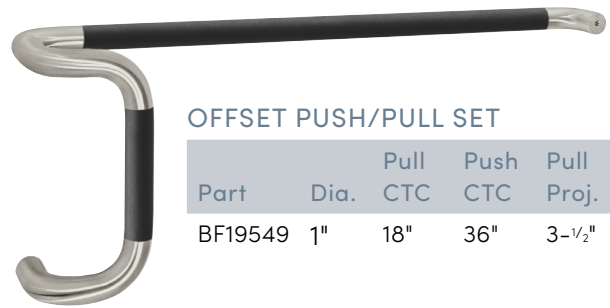

OFFSET PUSH/PULL SET

Part	Dia.	Pull CTC	Push CTC	Pull Proj.	Push Proj.
BF19549	1"	18"	36"	3-1/2"	2-3/4"



PUSH BAR

Part	Dia.	CTC	Proj.
49-BP	1"	36"	2-3/4"



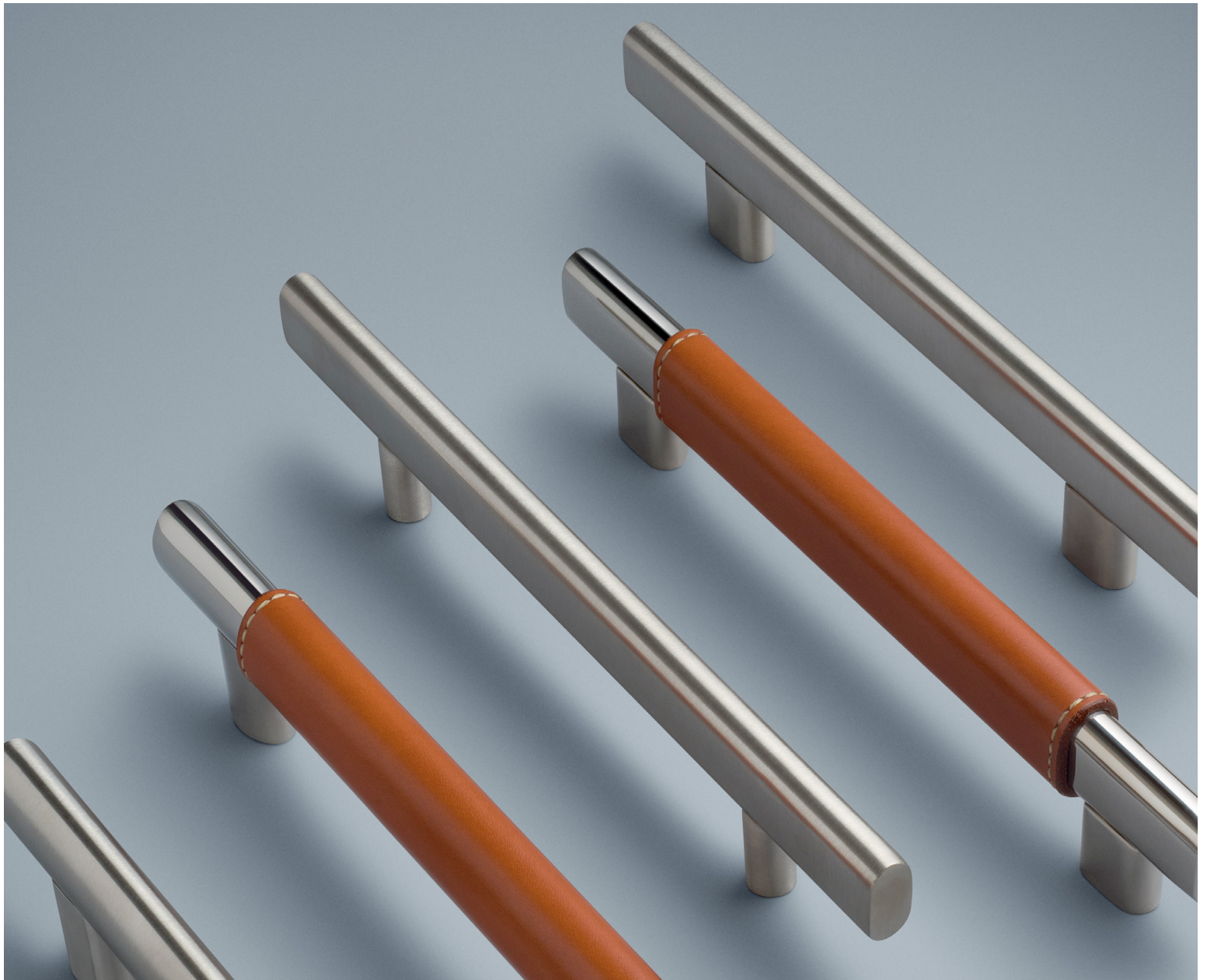

Oval Grip

Sturdy, sleek, and ergonomic, these collections offer the perfect combination of strength, style, and practicality. Available in flat or standard oval shapes, these attractive groupings provide the most ergonomic comfort for a door pull while still preserving a flair for elegance.

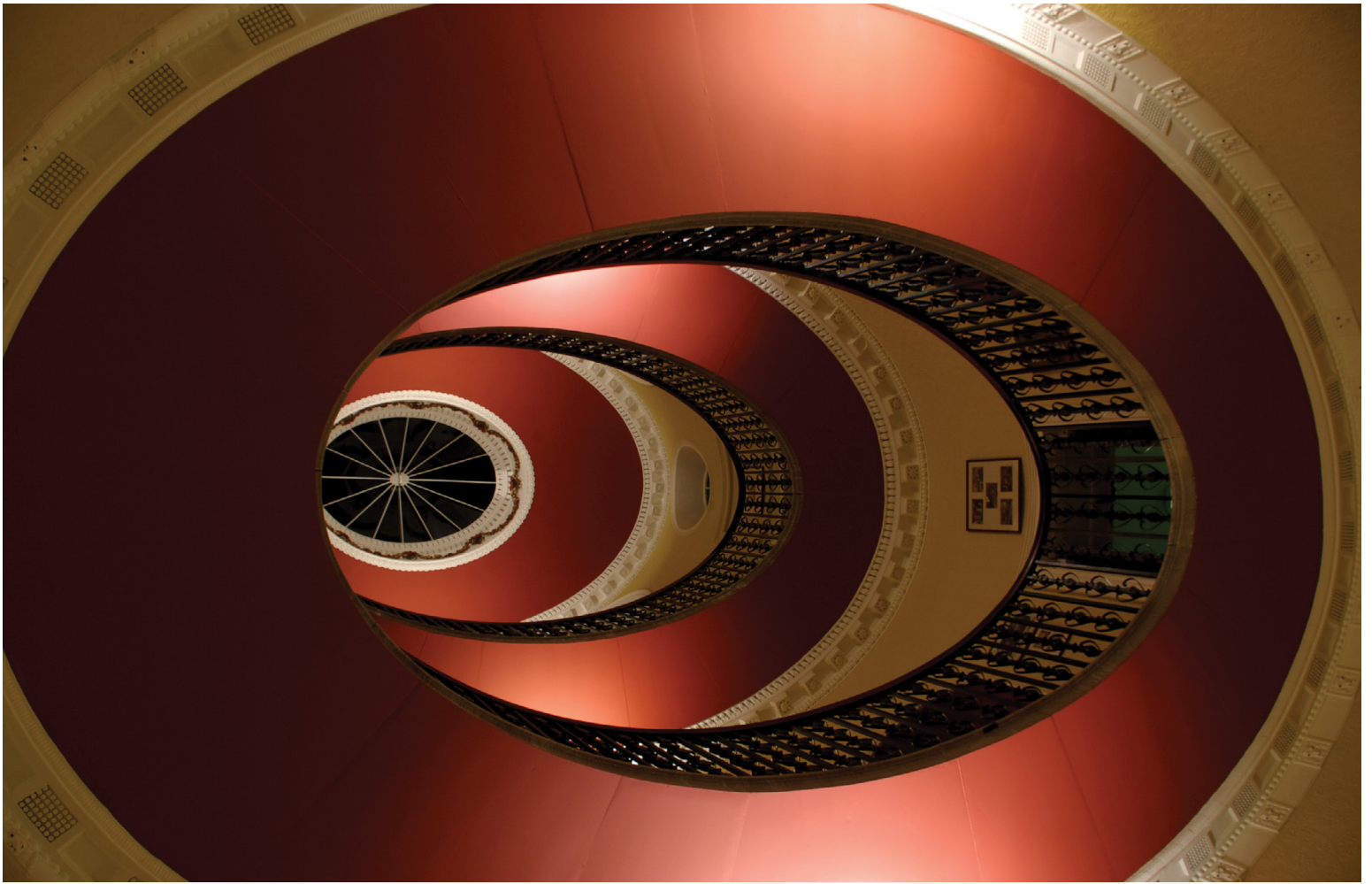

LEATHER

Expansive selection of high-quality, durable, leather door pulls

SMOOTH

Defining standards of comfort, conforming to the natural contours of the hand



LEATHER

Leather Oval

This collection mixes the smooth, durable sophistication of English Bridle or Upholstery leather with the ergonomic flair of an oval pull.



TRUE OVAL -
7/8" x 1 1/16" POSTS

Part	Grip Size	Proj.
RM6200	1" x 1 1/2"	3"

* Light Brown leather is shown.



FLAT OVAL -
3/4" DIAMETER POSTS

Part	Grip Size	Proj.
RM6220	3/4" x 1 1/2"	2 3/4"

* Light Brown leather is shown.



FLAT OVAL -
1" DIAMETER POSTS

Part	Grip Size	Proj.
RM6230	3/4" x 1 1/2"	3 3/4"

* Light Brown leather is shown.



FLAT OVAL - 3/4" X 1 1/2" POSTS

Part	Grip Size	Proj.
RM6240	3/4" x 1 1/2"	2 3/4"

* Light Brown leather is shown.

Projection shown excludes leather thickness.

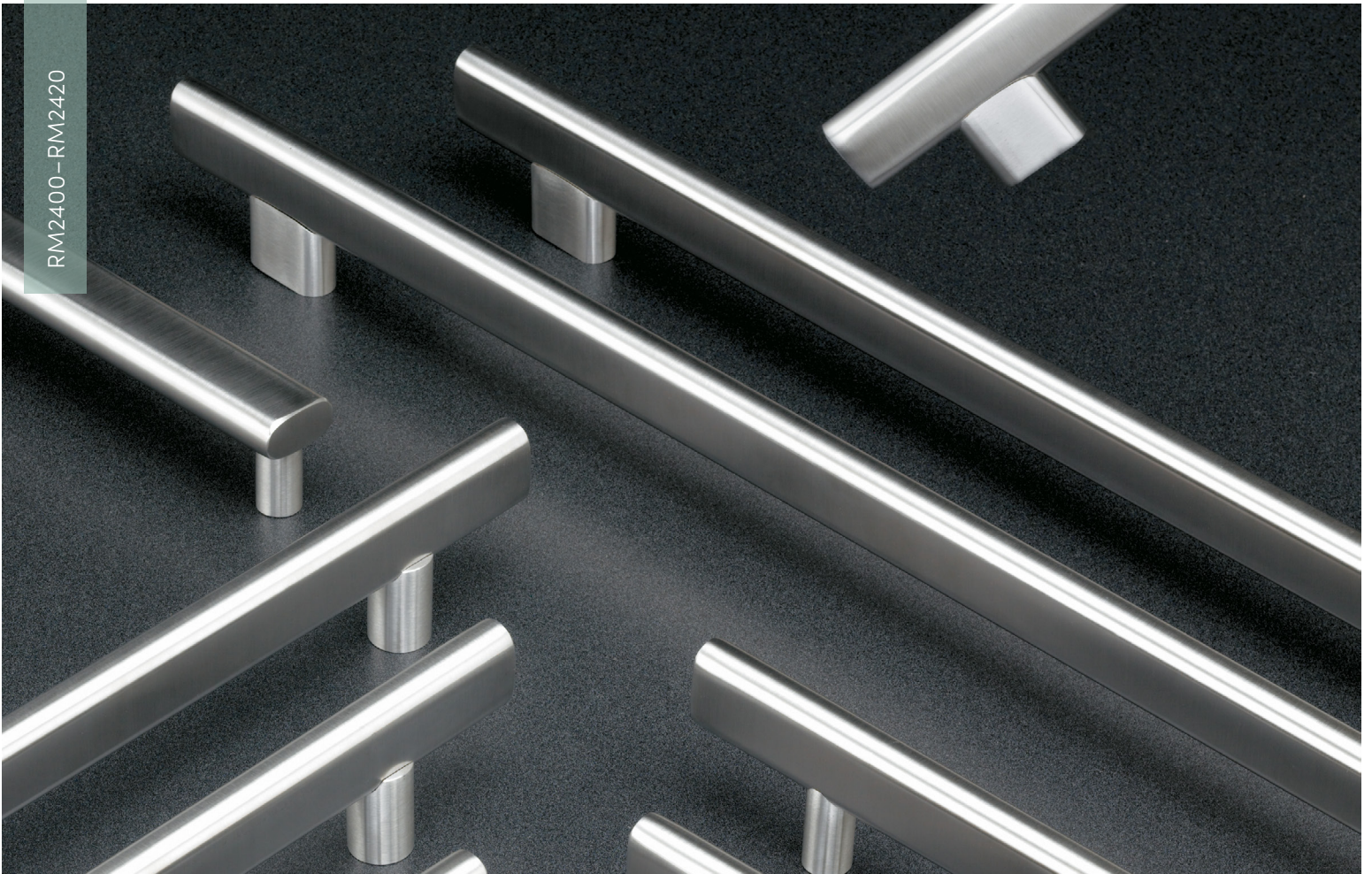

OvalTek™ with Flat Oval Grip

Trim lines and a sleek oval shape enhance these beautiful ergonomic pulls available in standard and full-height sizes with leather wrapping options.



**STRAIGHT PULL -
SMALL ROUND POST**

Part	Grip Size	Proj.
RM2400	3/4" x 1 1/2"	2 3/4"



**STRAIGHT PULL -
OBLONG POST**

Part	Grip Size	Proj.
RM2420	3/4" x 1 1/2"	2 3/4"



**STRAIGHT PULL -
LARGE ROUND POST**

Part	Grip Size	Proj.
RM2410	3/4" x 1 1/2"	3 1/4"



**PUSH BAR -
LARGE ROUND POST**

Part	Grip Size	Proj.
RM2402	3/4" x 1 1/2"	2"

RM2300 - RM2330

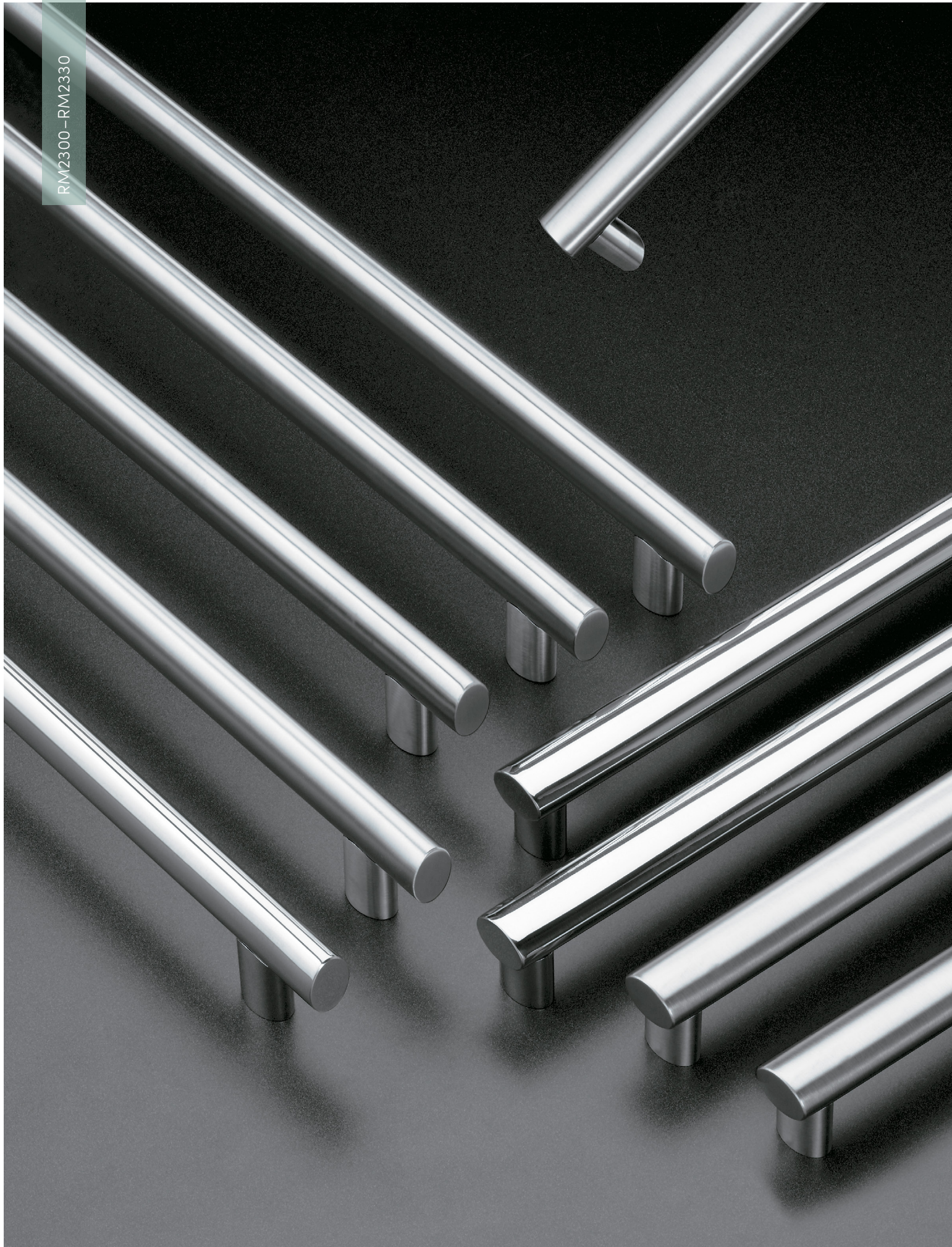

SMOOTH

OvalTek™ with True Oval Grip

With a naturally contoured grip, these post-mounted pulls set the standard for user comfort.



STRAIGHT OVAL PULLS

Part	Grip Size	Proj.
RM2300	1" x 1½"	3"
RM2310	1⅛" x 1⅞"	3⅜"



OFFSET OVAL PULLS

Part	Grip Size	Proj.
RM2320	1" x 1½"	2⅞"
RM2330	1⅛" x 1⅞"	3¼"



PUSH BARS

Part	Grip Size	Proj.
RM2302	1" x 1½"	2¼"
RM2312	1⅛" x 1⅞"	2¼"

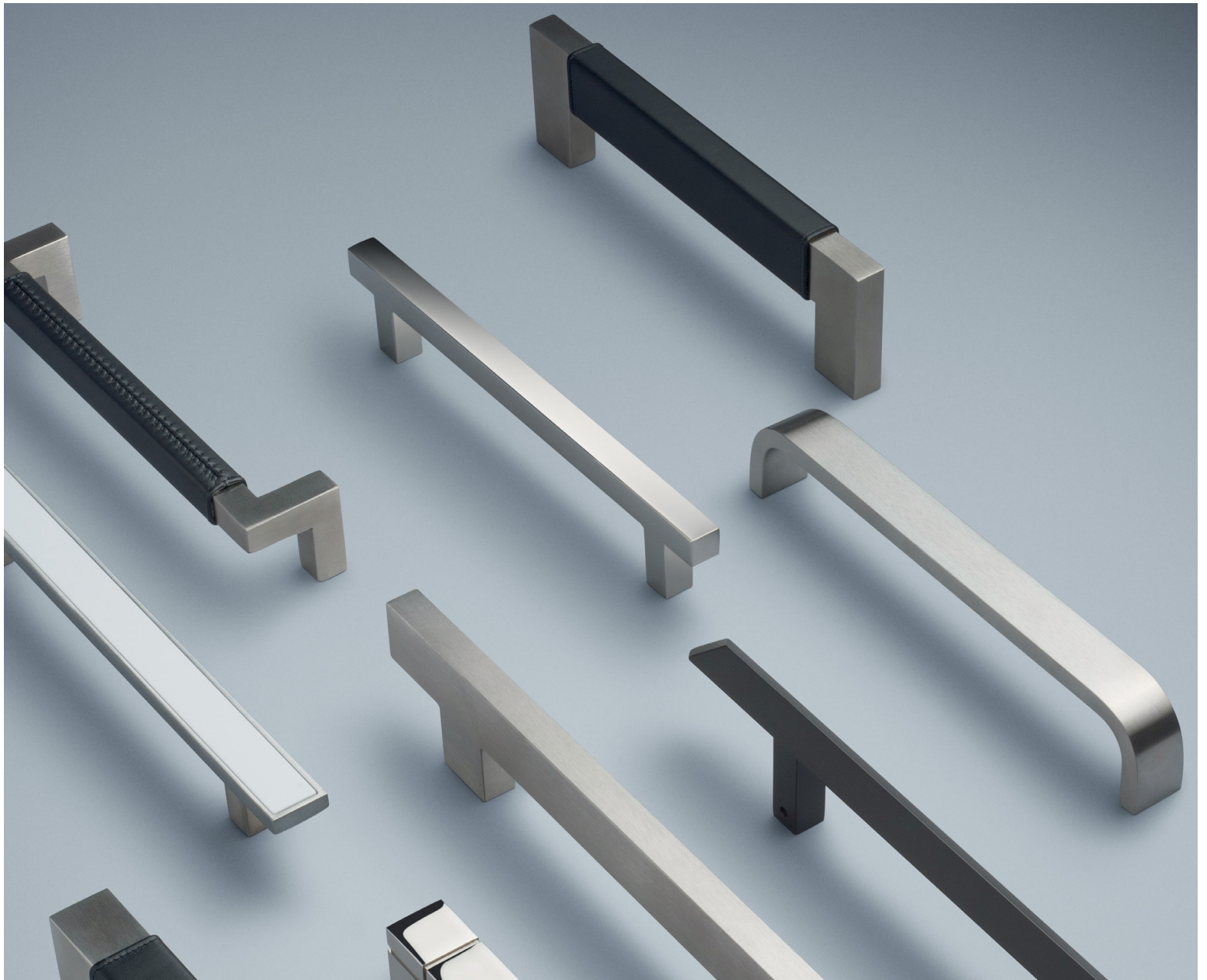

Square Grip

Clean lines and bold styling fuse to create these sturdy pulls. Available in a range of sizes and casting options, these daring pulls include features ranging from a contoured, comfort-focused grip to elegant monochrome accents. Choose your options to enhance any door.



LEATHER

Multiple color options, detailed stitching, and glove-soft leather

ACCENTS

Beautiful, angular design with intimations of white, black, or parting lines

DIAMOND

Distinct brilliance made complete with square or diamond ends and posts

SMOOTH

Narrow profile and clean lines in scalable style

RM6400-RM6440

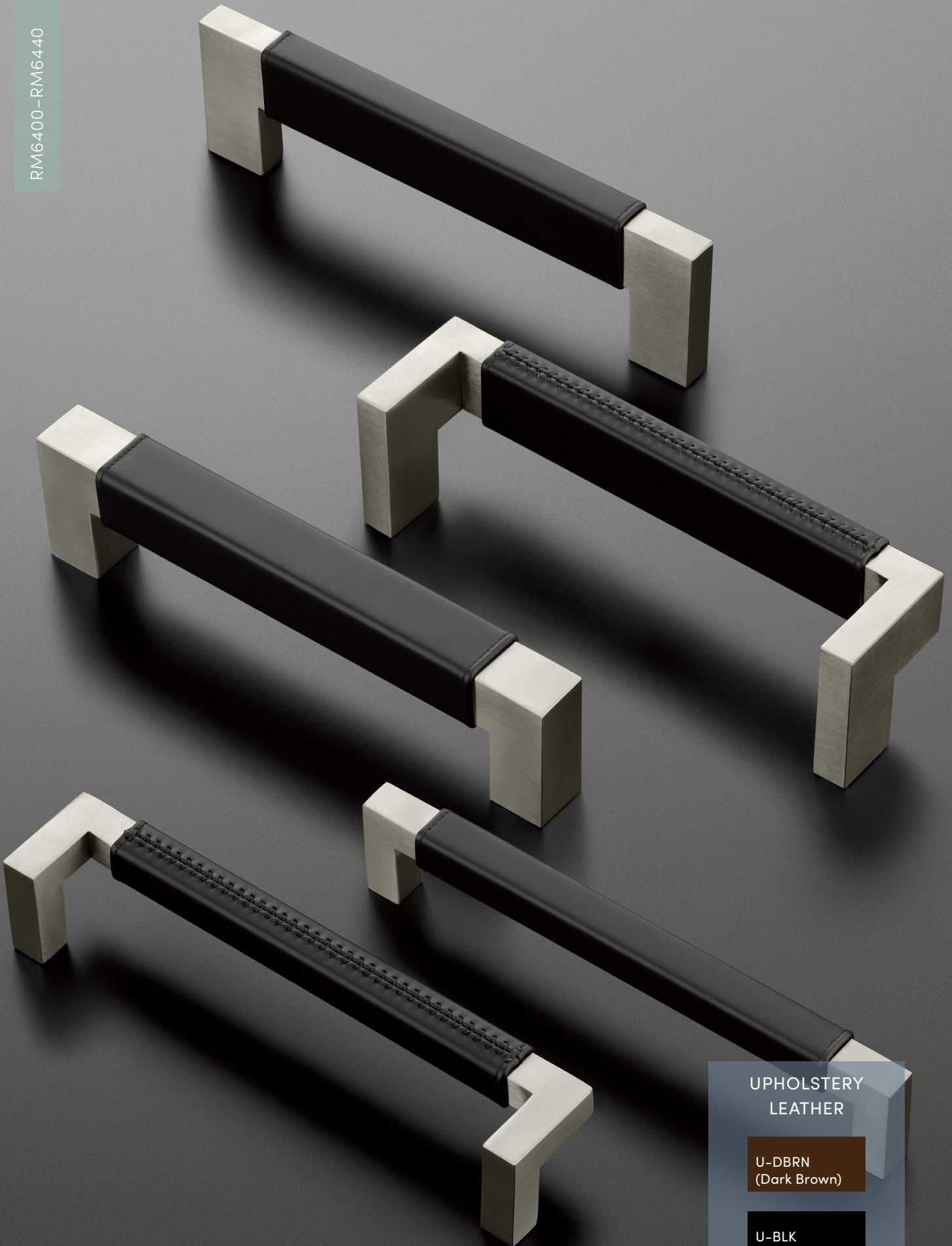

UPHOLSTERY
LEATHER

U-DBRN
(Dark Brown)

U-BLK
(Black)

LEATHER

GeoMetek™

Add contemporary flair to your door with these chic leather wrapped square and rectangular door pulls.



STRAIGHT PULLS - SQUARE ENDS

Part	Grip Size	Proj.
RM6400	3/4" x 3/4"	2 1/4"
RM6440†	1 1/4" x 1 1/4"	3"

† For locking pull options, see page 105.

* Black leather is shown.



OFFSET PULLS - SQUARE ENDS

Part	Grip Size	Proj.
RM6420	3/4" x 3/4"	2 1/4"

* Black leather is shown.



STRAIGHT PULLS - RECTANGULAR END

Part	Grip Size	Proj.
RM6410	3/4" x 1 1/2"	3"

* Black leather is shown.



OFFSET PULLS - RECTANGULAR ENDS

Part	Grip Size	Proj.
RM6430	3/4" x 1 1/2"	3 1/4"

* Black leather is shown.

Outside stitching must be specified when ordering.
Projection shown excludes leather thickness.



ACCENTS

AccenTek™

These pulls exude elegance using accents of white, black, or delicately parting lines.



CAST PULLS

Part	Grip Size	Proj.
RM4720	1 1/2" x 1/2" x 12 1/2"	2"
RM4700B	1 1/4" x 5/8" x 14"	2"
RM4700W	1 1/4" x 5/8" x 14"	2"

SCOOPED PULLS

Part	Diameter	Proj.
RM4850	1 1/4"	3"



SOLID GROOVED PULLS

Part	Grip Size	Proj.
RM4750	1/2" x 1 1/4"	2"
RM4755	3/4" x 1 1/4"	2 1/4"



HEXAGON

GeoMetek™

With a comfortable grip and precise edges, this hex shaped architectural door pull portrays balance, harmony, and unity.



FLAT END - SQUARE POST

Part	Grip Size	Proj.
RM7700	1" dia	2 ³ / ₄ "



DIAMOND

GeoMetek™

These pulls feature a beautifully angled diamond shape integrated into the posts or ends of the pull to create an unparalleled, distinctive look.



FLAT END -
SQUARE POST

Part	Grip Size	Proj.
RM7800	3/4" x 3/4"	27/8"
RM7840	1" x 1"	3 ⁵ / ₃₂ "



DIAMOND END -
SQUARE POST

Part	Grip Size	Proj.
RM7810	3/4" x 3/4"	27/8"
RM7850	1" x 1"	3 ⁵ / ₃₂ "



FLAT END -
DIAMOND POST

Part	Grip Size	Proj.
RM7805	3/4" x 3/4"	27/8"
RM7845	1" x 1"	3 ⁵ / ₃₂ "



DIAMOND END -
DIAMOND POST

Part	Grip Size	Proj.
RM7815	3/4" x 3/4"	27/8"
RM7855	1" x 1"	3 ⁵ / ₃₂ "



FLAT END -
OFFSET BRIDGE

Part	Grip Size	Proj.
RM7825	3/4" x 3/4"	27/8"
RM7860	1" x 1"	3 ²¹ / ₃₂ "



DIAMOND END -
OFFSET BRIDGE

Part	Grip Size	Proj.
RM7835	3/4" x 3/4"	27/8"
RM7865	1" x 1"	3 ²¹ / ₃₂ "

RM5200 - RM5280

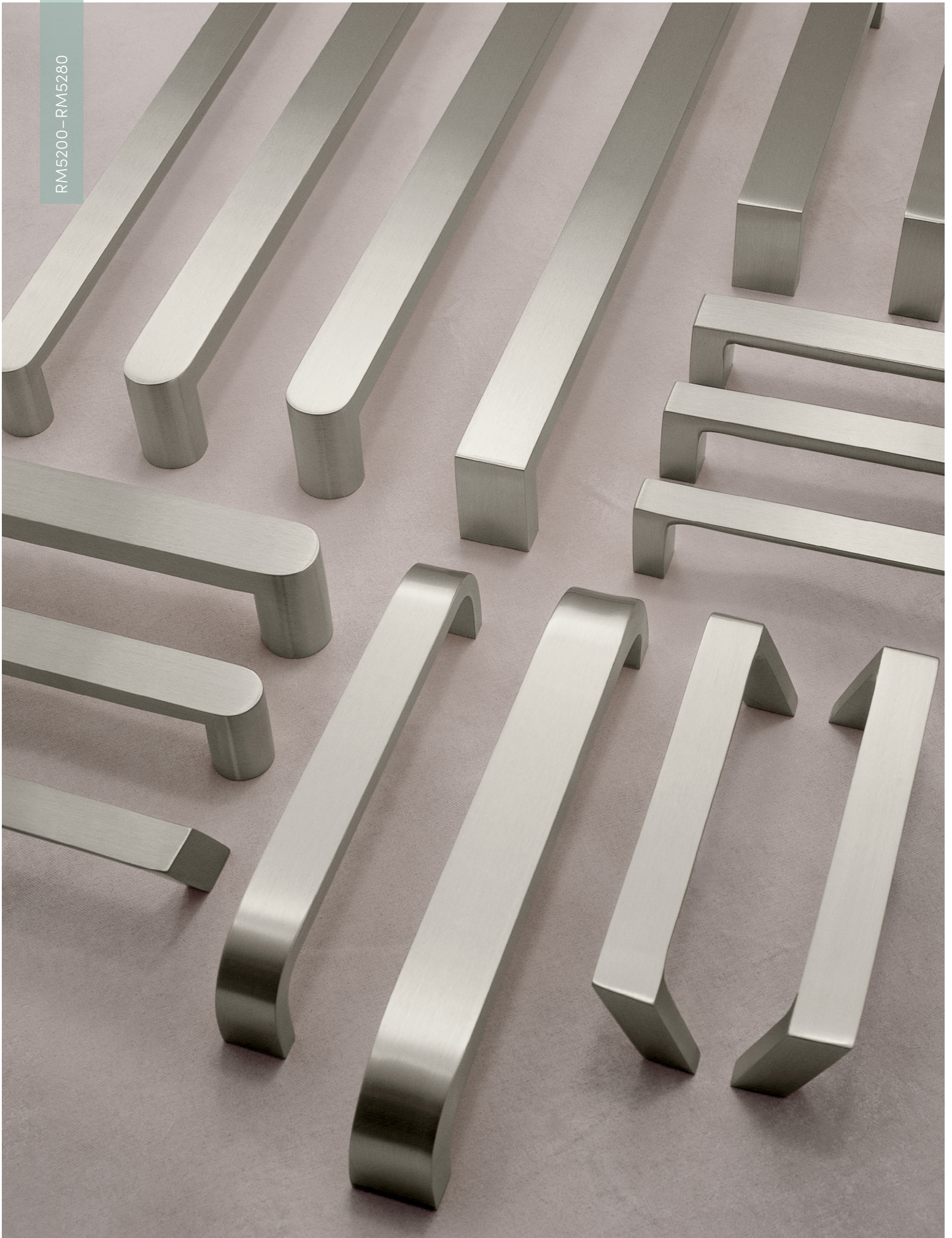

SMOOTH

PlanTek™

The options are endless. These cast pulls, with a contoured-back grip, are available in a range of sizes and stocks for a distinctive and alternative form.



STRAIGHT CAST PULLS

Part	Grip Size	CTC	Proj.
RM5200	1"	7", 12"	2"
RM5202	1 1/4"	12"	2"



STRAIGHT CAST PULLS

Part	Grip Size	CTC	Proj.
RM5280	1/2" x 1/2"	9"	1 1/2"



FLAT END PULLS

Part	Grip Size	Proj.
RM5230	1/2" x 1 1/4"	2 1/2"
RM5240	3/4" x 1 1/2"	2 1/2"



RADIUS END PULLS

Part	Grip Size	Proj.
RM5270	1/2" x 3/4"	2 1/2"
RM5275	1/2" x 3/4"	2 1/2"
RM5277	1/2" x 3/4"	2 1/2"

RM5270 RM5275 RM5277



For the complete suited collection, including matching lever designs, see The Good Design Studio section of the catalog.



OFFSET CAST PULLS

Part	Grip Size	CTC	Proj.
RM5204	1"	8", 12"	2"



BENT END PULLS

Part	Grip Size	Proj.
RM5250	1/2" x 1 1/4"	2 1/4"
RM5260	3/4" x 1 1/2"	2 1/4"



RADIUS END PULLS

Part	Grip Size	Proj.
RM5210	1/2" x 1 1/4"	2 1/2"
RM5220	3/4" x 1 1/2"	2 1/2"



RADIUS END PUSH BARS

Part	Grip Size	Proj.
RM5212	1/2" x 1 1/4"	2"
RM5222	3/4" x 1 1/2"	2"



FLAT END PUSH BARS

Part	Grip Size	Proj.
RM5232	1/2" x 1 1/4"	2"
RM5242	3/4" x 1 1/2"	2"

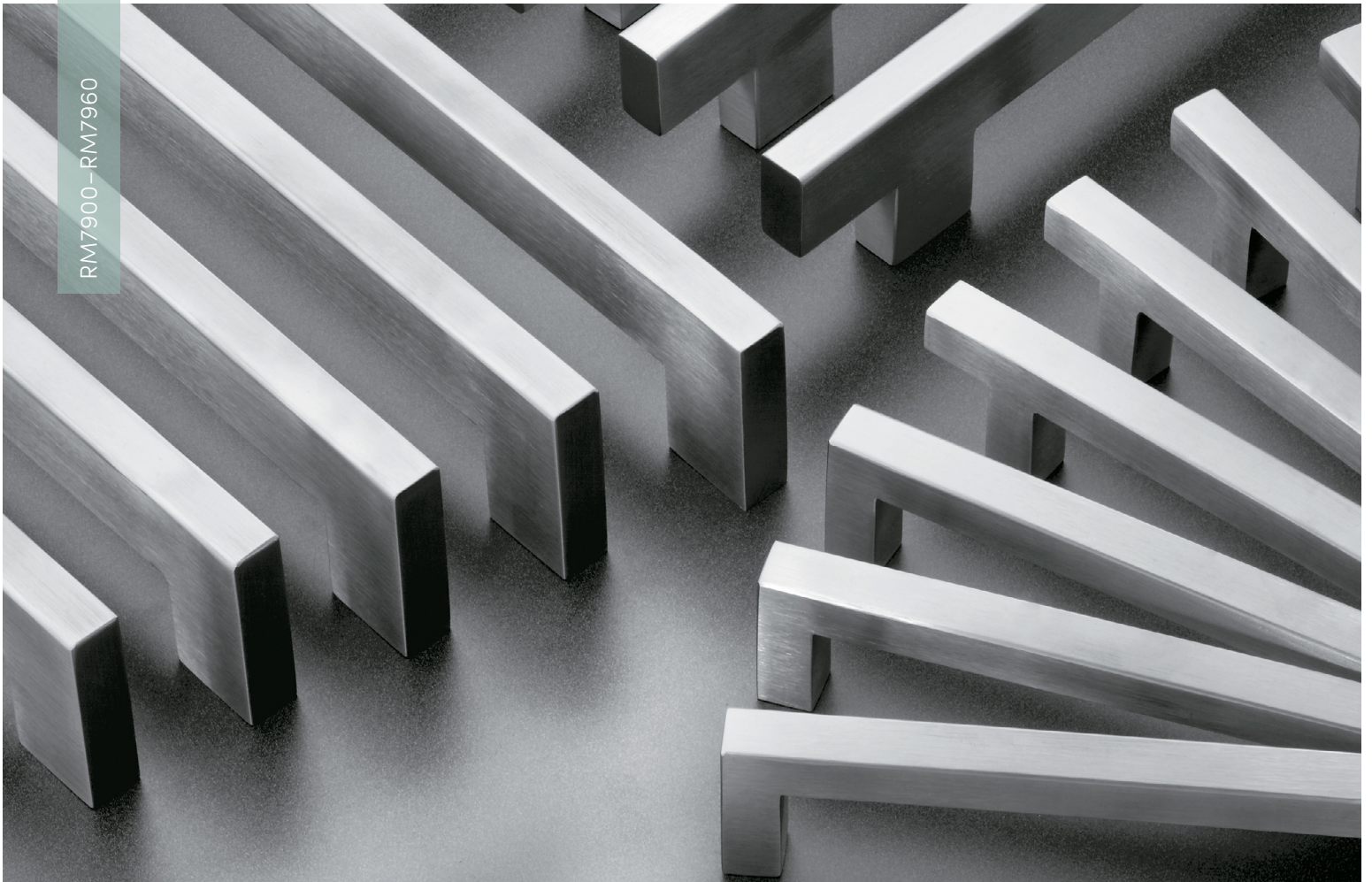

SMOOTH

GeoMetek™

The square and rectangular pulls offer clean lines and a slim profile.



RM7907



RM7940

STRAIGHT PULLS - SQUARE ENDS

Part	Grip Size	Proj.
RM7900†	3/4" x 3/4"	2 1/4"
RM7907	1" x 1"	2 3/4"
RM7940	1 1/4" x 1 1/4"	3"

† For locking pull options, see page 105.



STRAIGHT PULLS - RECTANGULAR ENDS

Part	Grip Size	Proj.
RM7910	3/4" x 1 1/2"	3"



**STRAIGHT SQUARE
BRIDGE PULLS**

Part	Grip Size	Proj.
RM7902	$\frac{3}{4}$ " x $\frac{3}{4}$ "	2 $\frac{1}{4}$ "
RM7917	1" x 1"	2 $\frac{3}{4}$ "



**OFFSET SQUARE
BRIDGE PULLS**

Part	Grip Size	Proj.
RM7925	$\frac{3}{4}$ " x $\frac{3}{4}$ "	2 $\frac{1}{4}$ "
RM7937	1" x 1"	2 $\frac{3}{4}$ "



**OFFSET PULLS - SQUARE/
RECTANGULAR ENDS**

Part	Grip Size	Proj.
RM7920 (Square)	$\frac{3}{4}$ " x $\frac{3}{4}$ "	2 $\frac{1}{4}$ "
RM7927 (Square)	1" x 1"	2 $\frac{3}{4}$ "
RM7930 (Rectangular)	$\frac{3}{4}$ " x 1 $\frac{1}{2}$ "	3 $\frac{1}{4}$ "



**OFFSET RECTANGULAR
BRIDGE PULLS**

Part	Grip Size	Proj.
RM7935	$\frac{3}{4}$ " x 1 $\frac{1}{2}$ "	3 $\frac{1}{4}$ "



**STRAIGHT RECTANGULAR
END STEPPED POST PULLS**

Part	Grip Size	Proj.
RM7960	$\frac{3}{4}$ " x $\frac{3}{4}$ "	2 $\frac{1}{2}$ "



**STRAIGHT RECTANGULAR
BRIDGE PULLS**

Part	Grip Size	Proj.
RM7912	$\frac{3}{4}$ " x 1 $\frac{1}{2}$ "	3"

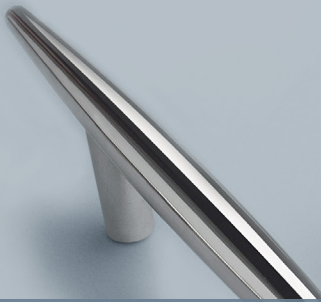

Sculpted Pulls

Add a sleek and graceful element to any door. Our collections offer symmetry, flowing shapes, the pleasing aspects of an ergonomic design, and custom options that provide the flexibility to blend with any environment using noticeable style that is delightful to behold and engage.



NON-TRADITIONAL

Precision curves, flowing design, sophisticated elegance

TRADITIONAL

Commercial, high-quality castings with enduring style



NON-TRADITIONAL

MariTek™

These versatile, solid-cast, post-mount pulls enhance any door location with character and appeal.



RM5700



RM5702

STRAIGHT DOOR PULLS

Part	Proj.	CTC	Grip Size
RM5700	2 ¹¹ / ₁₆ "	6"	1"
RM5702	2 ³ / ₄ "	12"	1"





NON-TRADITIONAL

MegaCurve™

Make your door a point of conversation. These long, precision-curved pulls, in standard or custom shapes, add enchantment and fascination to any entrance.



MID BOW

Part	Dia.	Proj.
RM2000	1¼"	3"
RM2004	1¼"	3"



LONG BOW PULLS

Part	Dia.	Proj.
RM2010	1¼"	3"
RM2014	1¼"	3"

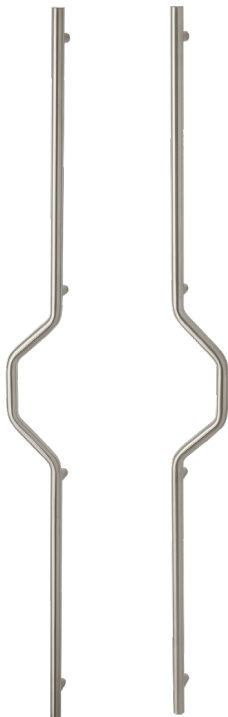

45° PULLS

Part	Dia.	Proj.
RM2020	1¼"	3"
RM2024	1¼"	3"

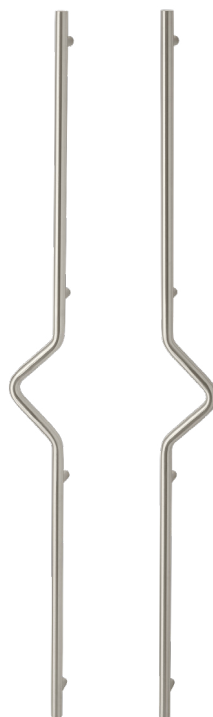

TRIANGLE PULLS

Part	Dia.	Proj.
RM2030	1¼"	3"
RM2034	1¼"	3"

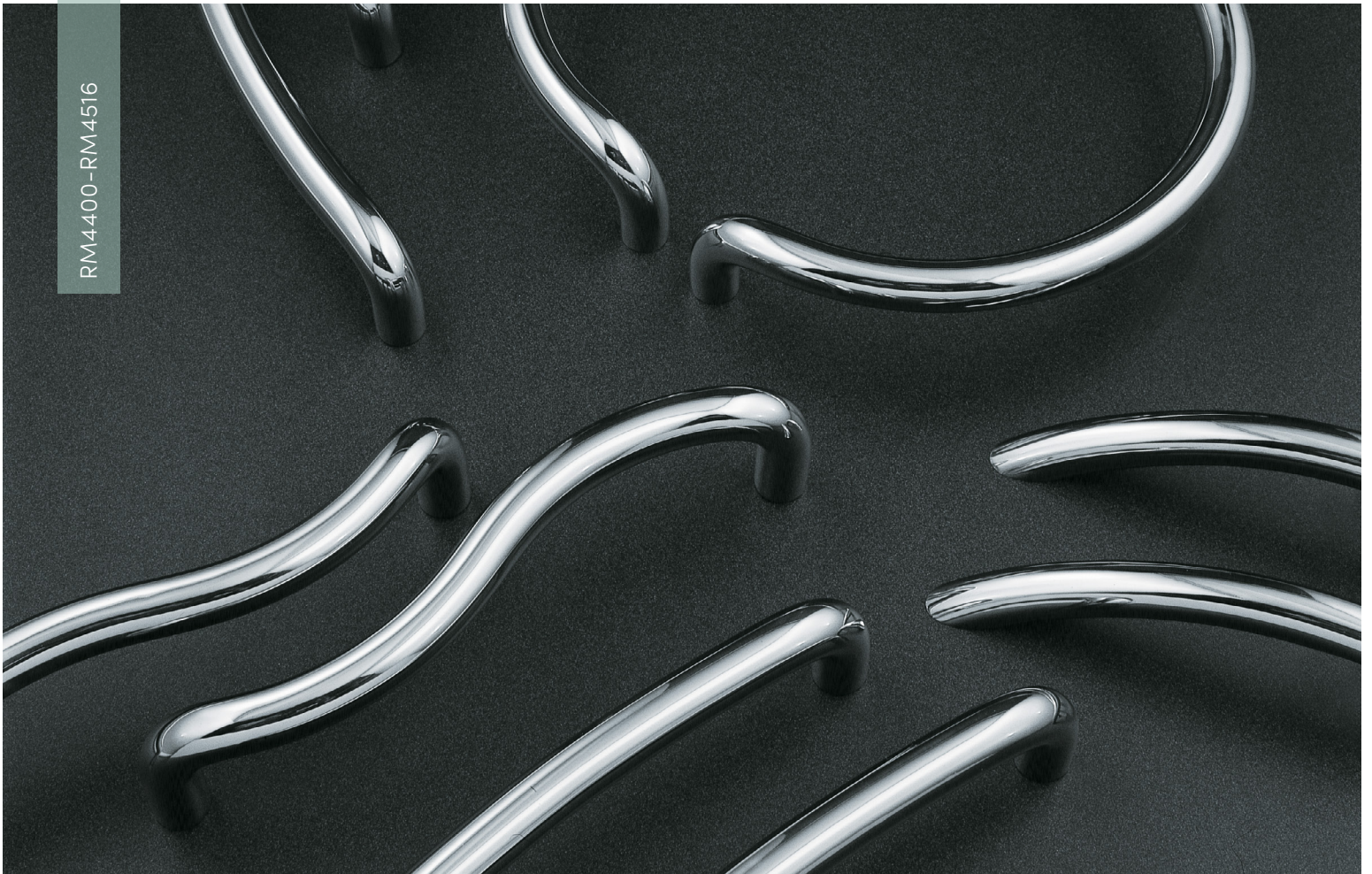

NON-TRADITIONAL

CenTrex™

Graceful and elegant, these smoothly curved pulls offer comfort in a sleek design. Use individually or mix with a push bar to create a unique and distinctive look.



SIDE RADIUS PULL

Part	Dia.	Proj.
RM4510	1¼"	3"



STRAIGHT RADIUS PULLS

Part	Dia.	Proj.
RM4410	1"	3"



PROJECTING RADIUS PULLS

Part	Dia.	Proj.
RM4512	1¼"	3⅞"



OFFSET RADIUS PULLS

Part	Dia.	Proj.
RM4412	1"	2½"

NON-TRADITIONAL

CenTrex™ (continued)



SEMI-CIRCULAR
PULLS - FLAT ENDS

Part	Dia.	Proj.
RM4502	1¼"	3"
RM4506	1¼"	3"



CURVED PULLS -
BENT ENDS

Part	Dia.	Proj.
RM4400	1"	3"



SEMI-CIRCULAR PULLS -
ROUND ENDS

Part	Dia.	Proj.
RM4500	1¼"	3"



DOUBLE CURVED PULLS -
BENT ENDS

Part	Dia.	Proj.
RM4402LH	1"	3"
RM4402RH	1"	3"



RADIUS PUSH BAR

Part	Dia.	Proj.
RM4516LH	1¼"	2¾"
RM4516RH	1¼"	2¾"



SEMI-CIRCULAR PULLS -
BENT ENDS

Part	Dia.	CTC	Proj.
RM4420	1"	9"	3"
RM4422	1"	12"	3"



RADIUS PUSH BARS -
BENT ENDS

Part	Dia.	Proj.
RM4440LH	1"	2½"
RM4440RH	1"	2½"



COMPOUND RADIUS
PUSH BARS - BENT ENDS

Part	Dia.	Proj.
RM4450LH	1"	2½"
RM4450RH	1"	2½"



TRADITIONAL

Classic

Traditional, decorative, and enduring, these pulls use finials, variable lengths, and optional base plates as custom elements to complement and enrich a classic style.



RM5650-3

PLAIN GRIP

Part	Dia.	Base Plate	Proj.
RM5650	1"	No	2 ¹ / ₁₆ "
RM5660	1"	Yes	3 ¹ / ₁₆ "



RM5652-4

ROPE GRIP

Part	Dia.	Base Plate	Proj.
RM5652	1"	No	2 ¹ / ₁₆ "
RM5662	1"	Yes	3 ¹ / ₁₆ "



RM5664-2

FLUTED GRIP

Part	Dia.	Base Plate	Proj.
RM5654	1"	No	2 ¹ / ₁₆ "
RM5664	1"	Yes	3 ¹ / ₁₆ "

* Shown with base plate



RM5670-1

PLAIN OFFSET

Part	Dia.	Base Plate	Proj.
RM5670	1"	No	2 ¹ / ₁₆ "

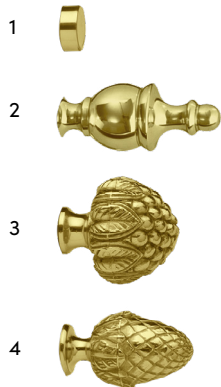

FINIAL STYLE NUMBER

(example: RM5650-4)

Suffix	Finial Style
1	Plain
2	Urn
3	Berry
4	Pinecone



OPTIONAL BASE PLATE

Dia.	Proj.
1 ³ / ₄ "	3 ³ / ₈ "

Projection shown excludes collar thickness.

RM5500 - RM5598



TRADITIONAL

Traditional

Solid, commercial-quality, decorative pulls and plates that offer durability with a tasteful flair.



CAST PULLS

Part	Dia.	CTC	Proj.
RM5500	No	6"	2 1/2"
RM5502	Yes	6 7/8"	2 7/8"
RM5510	No	12"	2 1/2"
RM5512	Yes	12 7/8"	2 7/8"
RM5520	No	8"	2 1/4"
RM5522	Yes	8"	2 5/8"
RM5530	No	5 1/2"	1 7/8"
RM5532	No	7 1/2"	1 7/8"
RM5534	No	12"	1 7/8"



CAST PLATES

Part	Size
RM5598B	3 1/2" x 15"
RM5596A	3" x 12"
RM5596B	3 1/2" x 15"

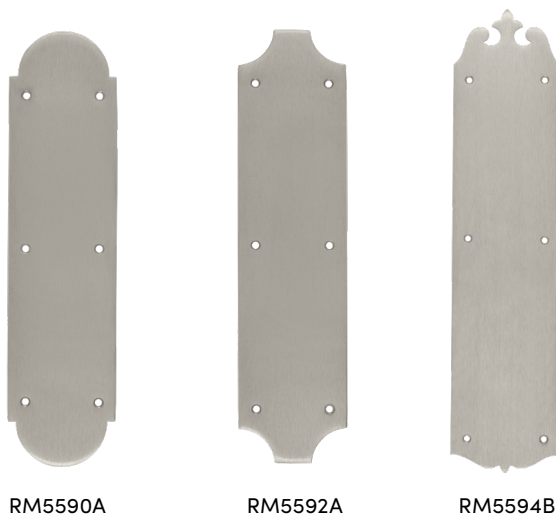

HEAVY PLATES - .090" THICK

Part	Size
RM5590A	3" x 12"
RM5590B	3 1/2" x 15"
RM5590C	4" x 16"
RM5592A	3" x 12"
RM5592B	3 1/2" x 15"
RM5592C	4" x 16"
RM5594B	3 1/2" x 15"

A close-up photograph of a Rockwood Panic Device (PDU8500) installed on a door. The device is a vertical, cylindrical metal handle with a flat security latch mechanism. The door is a dark reddish-brown wood. The word "PUSH" is engraved in large, bold, black capital letters on the lower part of the handle. The brand name "ROCKWOOD" is visible on the latch mechanism. The image is split into two horizontal sections by a semi-transparent blue band containing text.

Architectural Panic Devices

Safeguard your door while emanating flawless design with the Rockwood Panic Device. Incorporating a patented flat security latch, the PDU8500's engraved push area and boundary grooves make exit doors stand out in a crowd. With a selection of cylinder, pull, and finish choices, no concessions are needed.



FEATURES

Top latching panic device with flat security latch	Provides additional strike engagement that inhibits doors from popping open
Engraved latch lines	Ensures proper installation and alignment with the strike
Dampener in actuator assembly	Suppresses bounce in the door
Engraved push area and boundary grooves	Enhances visibility and tactility for a quick and easy exit
Adjustable stops on strikes include set screws	Minimizes movement of stops and secures them in place
Keyed and non-keyed options	Matches existing key system if required
Dogging feature	Depresses and holds device into place, adding convenience during operating hours
Single or Double Fail Safe/ Fail Sure Electric Strikes offered	Keeps doors locked until released

BENEFITS

APPLICATIONS:

- Large Conference Rooms
- Large Hotel, Office, and University Meeting Rooms
- Casino, Restaurant, Stadium Banquet Rooms
- Retail Storefront Doors
- Security Vestibules
- Cross-Corridor Doors

PATENTS, APPROVALS AND LISTINGS*:

- ANSI/BHMA A156.3-2014, Grade 1 Certified (32 and 32D finishes only)
- UL305 (2017)
- California Building Code (2019) Sec.11B-309.4 (Optional)*
- ADA Compliant

* This product was specifically designed to be used in the state of California or other areas where a 5 lb. activation force is required to meet ADA. For other geographies, we recommend using our standard PDU8500.



FINISH OPTIONS

- Satin Stainless Steel (US32D/630)
- Bright Stainless Steel (US32/629)
- Bright Stainless Steel with MicroShield® Antimicrobial Coating (US32MS)
- Satin Stainless Steel 316 Alloy (US32D316)
- Bright Stainless Steel 316 Alloy (US32316)
- Split Finish – Satin Stainless Steel Device (US32D/630) and Bright Stainless Steel Push Area (US32/629)
- Extra Dark Bronze Equivalent (314E)
- Black Suede Powder Coat (BSP)
- White Suede Powder Coat (WSP)
- Stock Powder Coats (Specify color)

ENGRAVED PUSH AREA FINISH OPTIONS

- Split Finish – 32D device; 32 push area



- 32D device with White Gloss Paint



- 32D device with Black Gloss Paint (standard if no infill finish is specified)



- BSP device, BSP push area (no infill) (standard if no infill finish is specified)



- BSP device with White Gloss Paint



- BSP device with Black Gloss Paint



- Split Finish – BSP device, 32 push area



EXTERIOR PULL OPTIONS

- No Mating Pull

- Full Height L-Shaped Pull (-1)

- Half Height L-Shaped Pull (-2)

- Full Height Straight Pull (-3)



- Half Height Straight Pull (-4)

- Short Centered Straight Pull (-5)

- Horizontal Straight Pull (-6)





Locking Pull System

Add beauty and convenience to your locking application. Flawlessly integrate the contemporary style of Rockwood's postmount or GeoMetek door pulls with an easy-to-install deadbolt locking system. Manufactured for strength and durability and designed with clean and appealing lines, these systems offer perfectly simple, elegantly flexible solutions.





FEATURES

- Key operated from outside; turn piece on inside
- Multiple cylinder options
- Door types: Glass, Wood, and Metal
- Multiple locking options: down, up, or both
- Standard bolt latch
 - Bolt location: 2" from face of door to centerline of bolt
 - Bolt has $\frac{13}{16}$ " travel with fine adjustment
- Patented flat latch option
 - Flat latch location: $2\frac{1}{8}$ " from face of door to centerline of latch
- Horizontal push/pull bar option
- Available in brass, bronze and stainless steel
- Dummy versions available

BENEFITS

- Cylinder and thumbturn location eliminates physical strain when locking and unlocking
- Bolt concealed inside pull provides a clean, streamlined look
- Simple door preparation allows for faster installation
- Requires only 2 holes for half height pulls, 3 holes for full height
- Suites with popular Rockwood door pulls, Corbin Russwin and Sargent lever handles, creating a continuum of design
- Offers flexibility in custom sizes for a variety of applications

LP3301-LP7901



LP3301 Series

POST MOUNT - ROUND

This basic post mounted pull is a clean and simple design. The simplicity adds contemporary beauty to standard entrance doors.



LP6161 Series

UPHOLSTERY LEATHER WRAPPED - ROUND

Supple yet durable leather makes a discriminating statement. Available in two standard colors and a palette of others on special order.



LP3401 Series

NEOMAX WITH GRIPZONE - ROUND

This beautiful bright and brushed two-tone finish provides a "wear" area for gripping the pull. This minimizes the appearance of small scratches caused by rings and keys.



LP6440 Series

GEOMETEK UPHOLSTERY LEATHER WRAPPED - SQUARE

Beautifully crafted, the GeoMetek and Upholstery Leather combination produces an elegant composition. The leather is tightly wrapped and neatly sewn on the back and is offered in a plethora of custom colors.



LP6061 Series

ENGLISH BRIDLE LEATHER - ROUND

Authentic J & E Sedgwick & Co. Ltd. bridle leather imported from Walsall, England is hand sewn by a talented craftsman. Typically used for saddles and equestrian products, this smooth durable leather is suitable for both interior and exterior applications.



LP7901 Series

GEOMETEK SMOOTH - SQUARE

This series offers a streamlined profile and crisp lines. The square pull complements the shape of the opening creating symmetrically balanced design.





Locking Door Pull Configurations

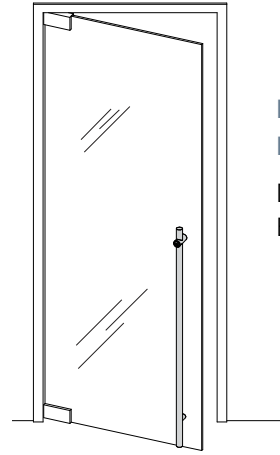

HALF HEIGHT
PULL - BOLTS DOWN
DBD (Dead
Bolt Down)

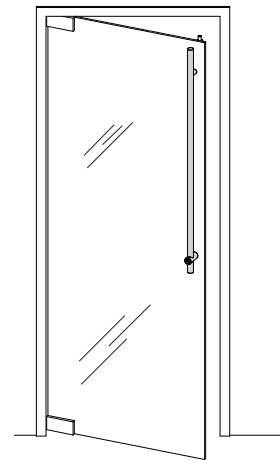

HALF HEIGHT
PULL - BOLTS UP
DBU (Dead
Bolt Up)

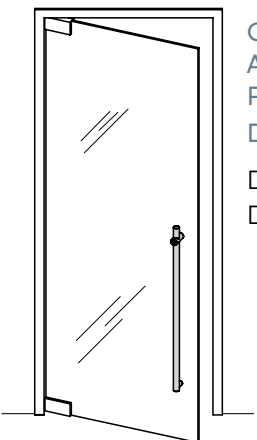

CLEARANCE
AND HALF HEIGHT
PULL - BOLTS
DOWN (LP3305)
DBD (Dead Bolt
Down)

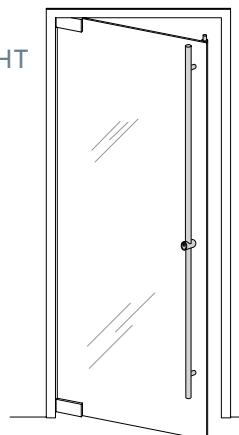

CLEARANCE
AND FULL HEIGHT
PULL - SINGLE
AND DUAL BOLT
MODELS (LP3305)
FHD (Full Height
Down) - Bolts Down
FHU (Full Height
Up) - Bolts Up
FHB (Full Height
Both) - Bolts Up
and Down

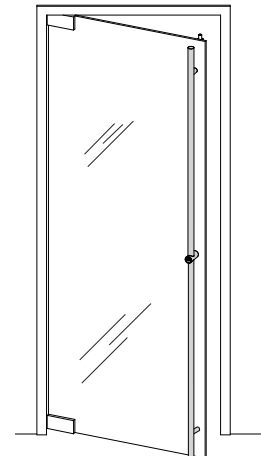

FULL HEIGHT PULL -
SINGLE AND DUAL
BOLT MODELS
FHD (Full Height
Down) - Bolts Down
FHU (Full Height
Up) - Bolts Up
FHB (Full Height
Both) - Bolts Up
and Down

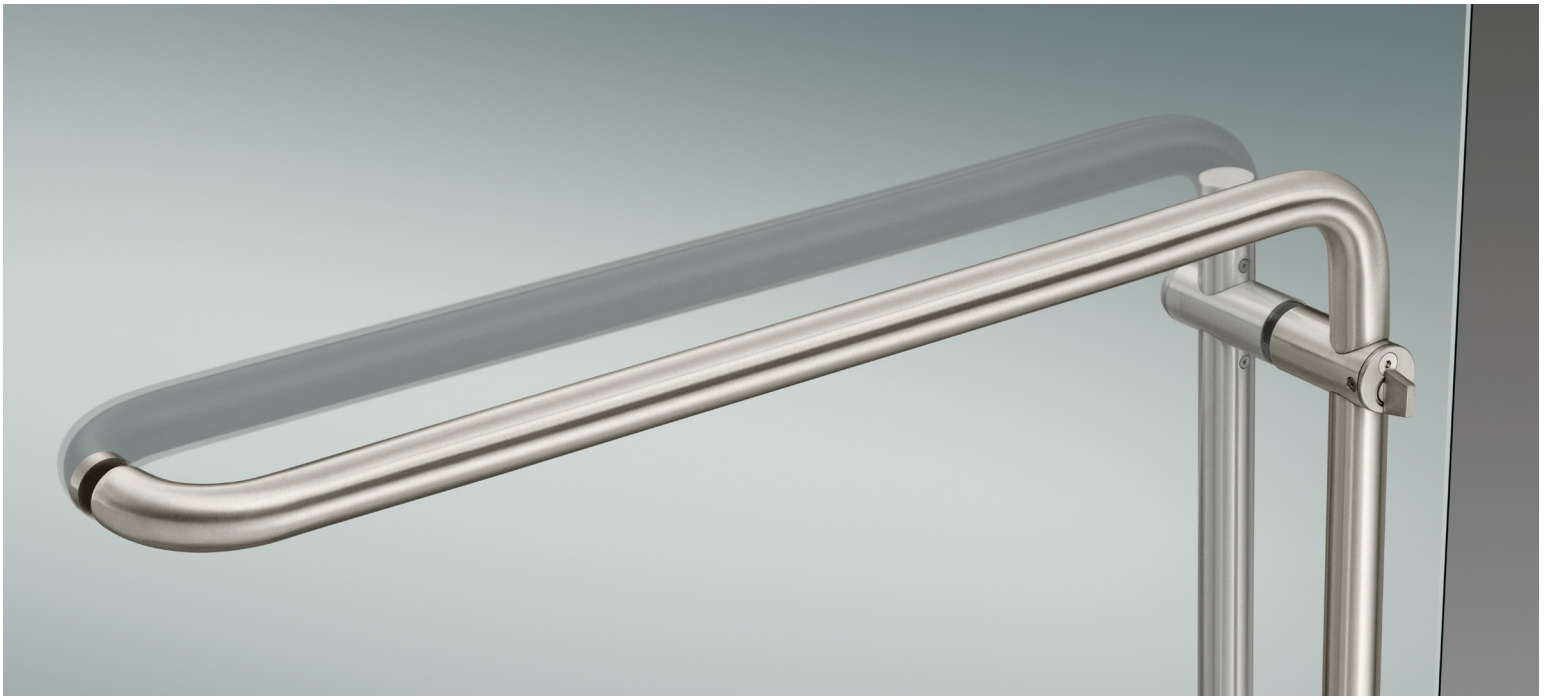

Horizontal Push/Pull Bar Configurations

Designation	Description
BEPB	Bent End Both Sides
BEPT	Bent End Thumbturn Side - Mating Side Vertical
BEPC	Bent End Cylinder Side - Mating Side Vertical

Designation	Description
PMPB	Post Mount Both Sides
PMPT	Post Mount Thumbturn Side - Mating Side Vertical
PMPC	Post Mount Cylinder Side - Mating Side Vertical

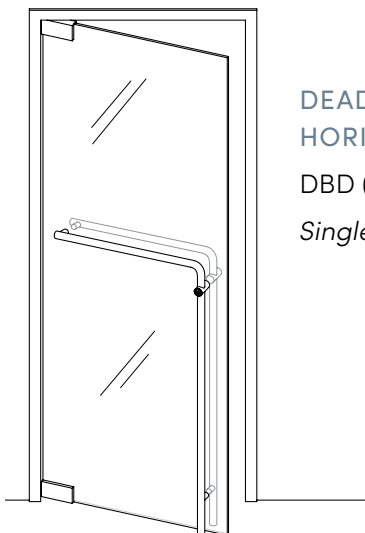
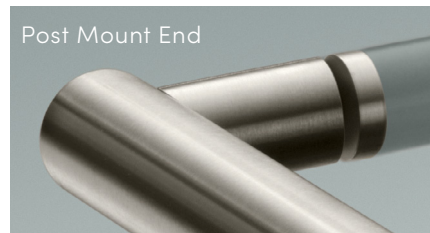

**DEAD BOLT DOWN -
HORIZONTAL BAR**
DBD (Dead Bolt Down)
Single or Double Sided

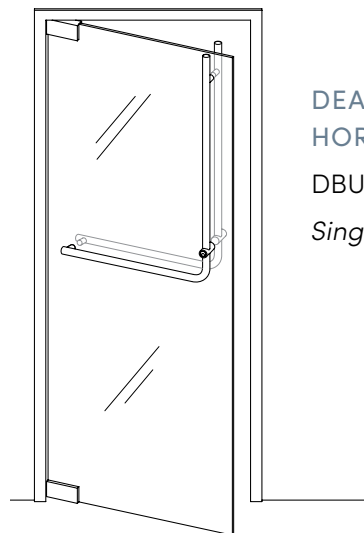

**DEAD BOLT UP -
HORIZONTAL BAR**
DBU (Dead Bolt Up)
Single or Double Sided



Sliding and Closet Pulls

Practical and modern style applications for sliding and closet doors. Our collections inspire visions of industrial sensibility, rustic charm, or seamless beauty. These pulls come in a variety of custom sizes and finishes to meet any application need.





SLIDING

Industrial style with decorative, rustic finishes

CLOSET

Simple closet door solutions in a variety of attractive designs and finishes

RM4800-RM4820



RM5250 PlanTek Pull also shown



SLIDING

AccenTek

These pulls offer a modern, industrial look with exposed fasteners and rustic finishes.

FORMED PULLS WITH DISTINGUISHED FASTENER HEADS



Part	Grip Size	Proj.
RM4800	3/4" dia	2 1/2"

FORMED PULLS WITH DISTINGUISHED FASTENER HEADS



Part	Grip Size	Proj.
RM4810	1 1/2" x 1/4"	1/4"



RM4280 Side View

FORMED PULLS WITH DISTINGUISHED FASTENER HEADS



Part	Grip Size	Proj.
RM4820	1 1/2" x 3/16"	1 15/16"

RM780-RM790



SLIDING

Flush Pulls

Recessed pulls used on bypass or sliding doors that don't protrude past the face of the door.



Part	Size	Opening	Depth
RM780	2 ³ / ₁₆ " x 3 ¹ / ₄ "	7 ⁷ / ₈ " x 2 ³ / ₈ "	3 ³ / ₄ "



Part	Size	Opening	Depth
RM782	2 ¹¹ / ₁₆ " x 4 ³ / ₁₆ "	1 ⁷ / ₁₆ " x 3 ⁷ / ₁₆ "	3 ³ / ₄ "



Part	Size	Opening	Depth
RM785	3 ¹ / ₂ " dia	2 ⁵ / ₈ " x 1 ⁵ / ₈ "	7 ⁷ / ₈ "



Part	Width	Size	Opening	Depth
RM790	2"	Min: 5" OA Max: 38" OA	1" w	5 ⁵ / ₈ "

MOUNTING OPTIONS:

- Concealed - Single or double sided, screws not visible
- Surface - Single or double sided, screws visible
- Prepped for Pull - RM790 one side, screws visible, mating door pull other side



CLOSET

Closet Pulls

Simplicity and practicality combined into a pull that is fabricated to your specifications.



RM715

CLOSET DOOR PULLS

Part	Dia.	Base Plate	Proj.
RM710	3/8"	No	1 1/2"
RM715	3/8"	Yes	1 1/2"
RM720	1/2"	No	1 3/4"
RM725	1/2"	Yes	1 7/8"
RM730	5/8"	No	2"
RM735	5/8"	Yes	2 1/8"



CLOSET

Edge Pulls

A variety of finishes, sizes, and solutions to handle any door application.



RM752

FLAT EDGE DOOR

Part	Return	Rolled Size
RM751	No	7/16"
RM752	Yes	7/16"



DOUBLE EDGE PULL

Part	Rolled Size
RM755	7/16"



RM753

BEVEL EDGE DOOR

Part	Return	Rolled Size
RM753	No	7/16"
RM754	Yes	7/16"



CONCEALED EDGE PULL

Part	Size
RM760	1" x 4 1/4"

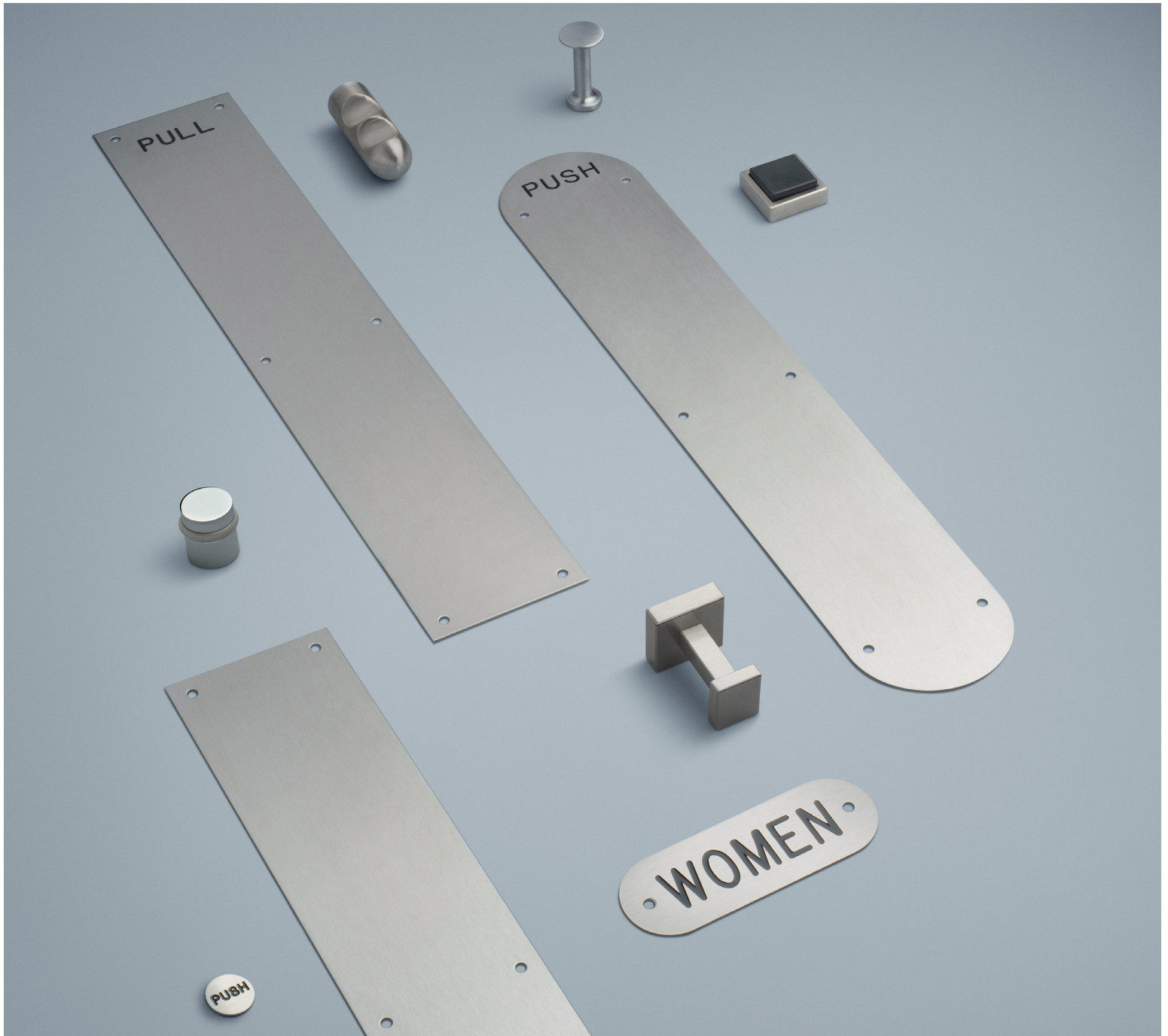

Accessories

Enhance your setting. Our collections of coat hooks, door stops, push/pull plates, and signage provide an added element of interest to your door area. Precision-manufactured and durable, these accessories can be customized to match specific door pull selections with resilient beauty.



COAT HOOKS

Solid brass, bronze, or stainless steel materials with tasteful finish options

DOOR STOPS

Durable, long-lasting style

PUSH PLATES, PULL PLATES, AND SIGNAGE

Detailed and available with design options to match our pulls

Coat Hooks

Available in most architectural finishes, our collection of coat hooks add an element of convenience to enhance any environment.



RM801



RM802



RM803

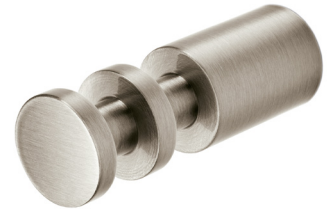

RM804



RM805
RM807



RM806
RM808



RM811

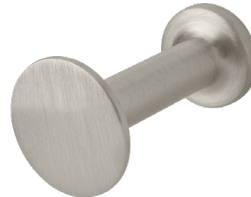

RM812



RM813

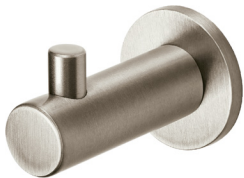

RM820

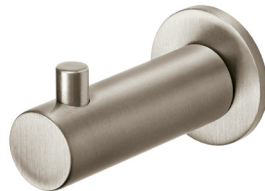

RM821



RM822



RM823



RM828



RM829

ESSENTIAL COAT HOOKS

Part	Size	Part	Size
RM801	1 1/4" x 1 3/4"	RM812	1 1/4" x 2 1/4"
RM802	1 1/4" x 2 3/4"	RM813	3/4" x 3"
RM803	1" x 2"	RM820	1/2" x 1 5/8"
RM804	1" x 3"	RM821	5/8" x 2 1/8"
RM805	1" x 1 3/4"	RM822	1/2" x 1 1/2"
RM806	1" x 3"	RM823	5/8" x 2"
RM807	1 1/4" x 2 1/8"	RM828	3/4" x 2 7/8"
RM808	1 1/4" x 3 1/2"	RM829	3/4" x 1 7/8"
RM811	3/4" x 1 5/8"		

ACCESSORIES

Coat Hooks (continued)

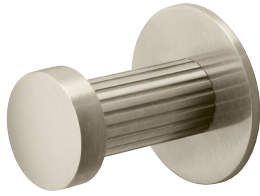

RM830

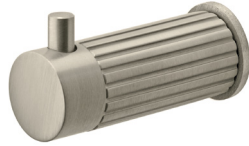

RM831

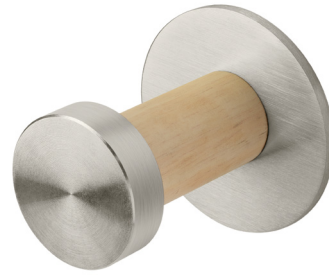

RM835



RM836

LINEAMET COAT HOOKS

Part	Base Plate	Size
RM830	Yes	1 1/4" x 2 1/8"
RM831	Yes	7/8" x 2 1/8"

ARBORMET COAT HOOKS

Part	Base Plate	Size
RM835	Yes	1 1/4" x 2 1/8"
RM836	Yes	7/8" x 2 1/8"

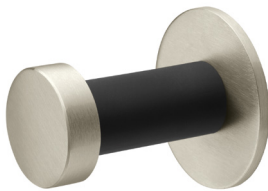

RM838



RM839

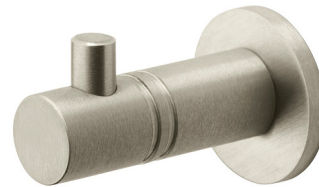

RM840
RM841



RM842
RM843

SOFTMET COAT HOOKS

Part	Base Plate	Size
RM838	Yes	1 1/4" x 2 1/8"
RM839	Yes	7/8" x 2 1/8"

GROOVE COAT HOOKS

Part	Base Plate	Size
RM840	Yes	1/2" x 1 5/8"
RM841	Yes	5/8" x 2 1/8"
RM842	No	1/2" x 1 1/2"
RM843	No	5/8" x 2"

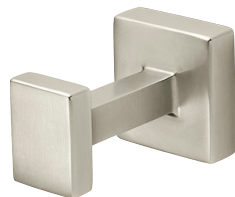

RM817

GEOMETEK COAT HOOKS

Part	Size	Proj.
RM817	1 1/8" x 1 3/4"	2 11/16"

Door Stops

Complete your look with these durable rubber door stops for walls, doors, and baseboards.



RM850



RM851



RM855



RM856



RM857

FLOOR MOUNTED

Part	Description	Base	Proj.
RM850	Short - Flat Top	1¼"	1½"
RM851	Tall - Flat Top	1¼"	2½"
RM855	Short - Round Top	1¼"	1¾"
RM856	Tall - Round Top	1¼"	2¾"
RM857*	Tall - Square	1"	2¾"

* Can be used as a base board mounted stop.
 + RM850-RM856 Specify BB for black bumper



RM860



RM861



RM867

WALL MOUNTED

Part	Bumper	Base	Proj.
RM860	Convex	1⅝"	1⅜"
RM861	Concave	1⅝"	1⅜"
RM867	Flat Square	1¾"	¾"

*RM860-RM861 Bumper color available in gray (standard) and black.

Door Stops (continued)



RM870

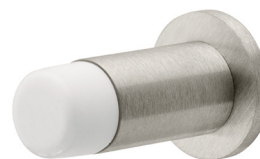

RM875



RM871



RM876



RM872



RM877

BASEBOARD MOUNTED

Part	Base Plate	Base	Proj.
RM870	No	5/8"	1 1/2"
RM871	No	5/8"	3 1/4"
RM872	No	5/8"	3 3/4"
RM875	Yes	1"	1 5/8"
RM876	Yes	1"	3 3/8"
RM877	Yes	1"	3 7/8"

Bumper color available in white (standard), gray and black.



Push Plates, Pull Plates, and Signage

Standard and custom-engraved options are available for these push and pull plates.

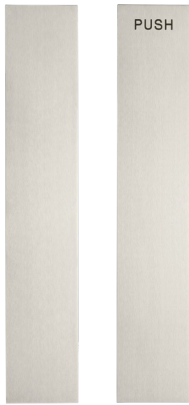

SQUARE CORNERS - ADHESIVE MOUNT

Part	Engraved	Size
RM1010	Blank	4" x 22"
RM1010H	PUSH	4" x 22"
RM1010L	PULL	4" x 22"

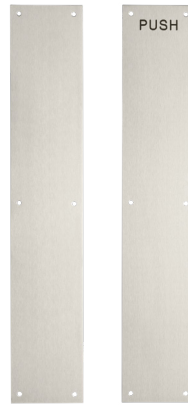

SQUARE CORNERS - SCREW MOUNT

Part	Engraved	Size
RM1020	Blank	4" x 22"
RM1020H	PUSH	4" x 22"
RM1020L	PULL	4" x 22"

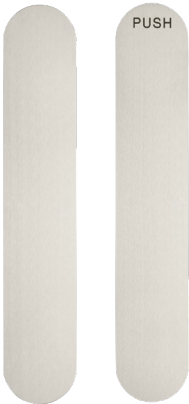

RADIUS END CORNERS - ADHESIVE MOUNT

Part	Engraved	Size
RM1030	Blank	4" x 22"
RM1030H	PUSH	4" x 22"
RM1030L	PULL	4" x 22"

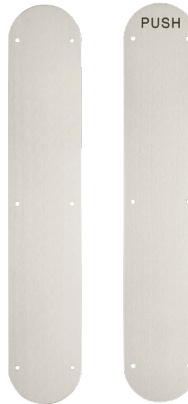

RADIUS END CORNERS - SCREW MOUNT

Part	Engraved	Size
RM1040	Blank	4" x 22"
RM1040H	PUSH	4" x 22"
RM1040L	PULL	4" x 22"



INDICATOR PLATES - PUSH/PULL

Part	Engraved	Size	Mounting
RM1110H	PUSH	1"	Adhesive
RM1110L	PULL	1"	Adhesive
RM1120H	PUSH	2½"	Adhesive
RM1120L	PULL	2½"	Adhesive



INDICATOR PLATES - MEN/WOMEN

Part	Engraved	Size	Mounting
RM1150M	MEN	2" x 4"	Adhesive
RM1150W	WOMEN	2" x 5¾"	Adhesive
RM1160M	MEN	2" x 4"	Screw
RM1160W	WOMEN	2" x 5¾"	Screw



Custom Door Pulls

Are you looking for door hardware that is different, funky, or suites with other components in your facility and is not shown in our current offering? The ASSA ABLOY custom hardware program offers a myriad of options to turn your dreams into beautiful reality.

CUSTOM DOOR PULLS

First impressions are everything

Door pulls are the gateway into a building. Whether you're looking for drama or elegance, ASSA ABLOY Rockwood door pulls can be highly customized, making your ideas come to life. Made with top-notch quality materials including various metals, leather, and wood, we use a selection of manufacturing processes to produce your custom design.

CUSTOM MACHINING

Computer controlled machining techniques including water jet cutting and milling enable precision fabrication and the efficient production of designs.

CORPORATE IDENTITY

Incorporate your company logo on a door opening through computer aided etching or engraving. These durable marking techniques are readily available to add that finishing touch.

CUSTOM CASTING

Working with a variety of pattern makers, we can produce the exact design you compose. Castings provide a unique surface texture and can be economical when you have more than a few to make.

CUSTOM BENDING

A variety of bent shapes are displayed in our standard product line, however, we can bend a radius of your choice on any material you select.

CUSTOM MATERIALS

Our leather craftsmanship expresses our attention to detail as each leather door pull is hand stitched. We apply equal expertise to our door pull fabrication by using the finest bridle or upholstery leather, in any custom color you desire.

Wood adds an element of warmth to your opening. We offer a selection of premium species including Mahogany, Canary and Walnut. Paired with numerous metal finishes, including custom colors, the options are endless.

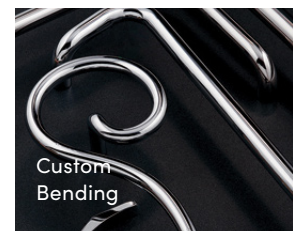
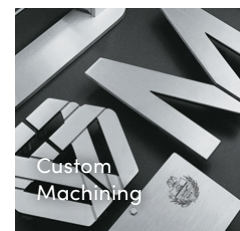
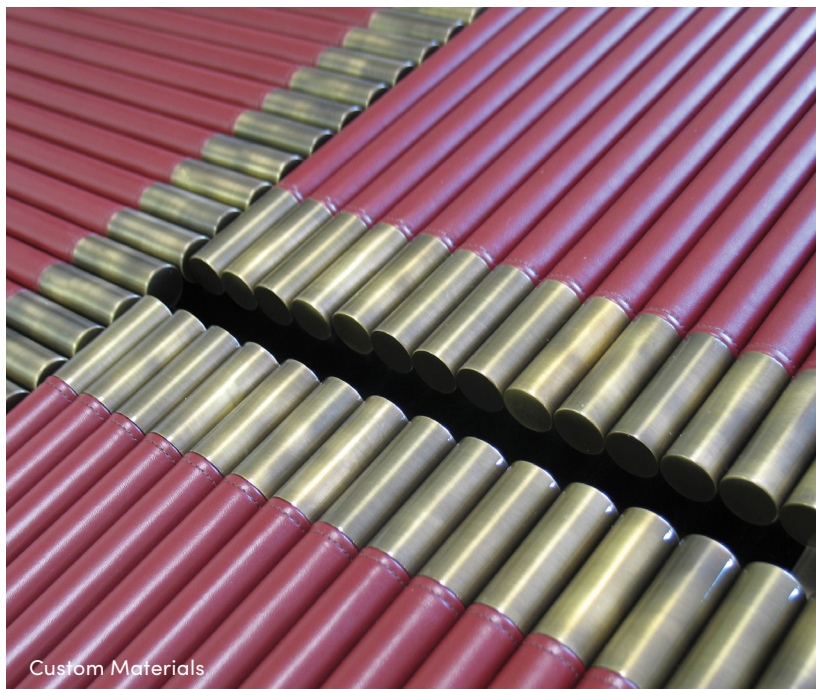

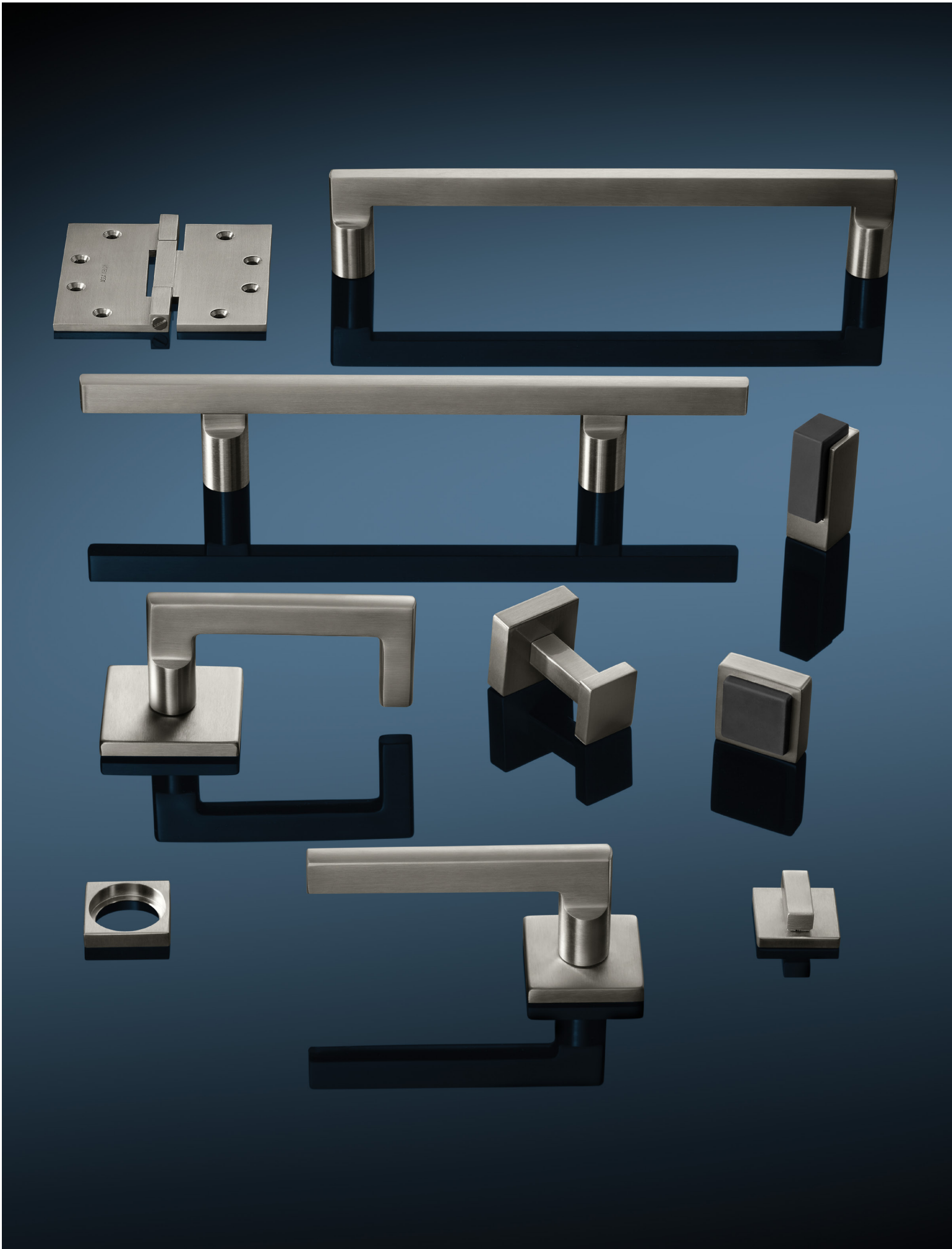

Collection 3



Corbin Russwin 21L and
SARGENT RAL Lever

* Dark Brown leather is shown.



Rockwood Flush
Leather Door Pull



McKinney Two Knuckle
Hinge with Flat Tips



Rockwood RM850
Door Stop



Rockwood RM801
Coat Hook

Collection 6



Corbin Russwin 21S and
SARGENT RAS Lever



Rockwood
SoftMet Door Pull



Rockwood SoftTek
Door Pull



McKinney Five Knuckle
Split Finish Hinge



Rockwood RM850
Door Stop



Rockwood RM839
Coat Hook



Rockwood RM838
Coat Hook

Collection 10



SARGENT MD/
Corbin Russwin 102/
ASSA ABLOY ACCENTRA
TB Levers



SARGENT ND/
Corbin Russwin 124/
ASSA ABLOY ACCENTRA
UB Levers



Rockwood
RM5270
Door Pull



Rockwood
RM5275
Door Pull



Rockwood
RM5277
Door Pull



McKinney Two Knuckle
Square Barrel Hinge



Rockwood RM867
Wall Stop



Rockwood RM857
Floor Stop



Rockwood RM817
Coat Hook

Technical Information



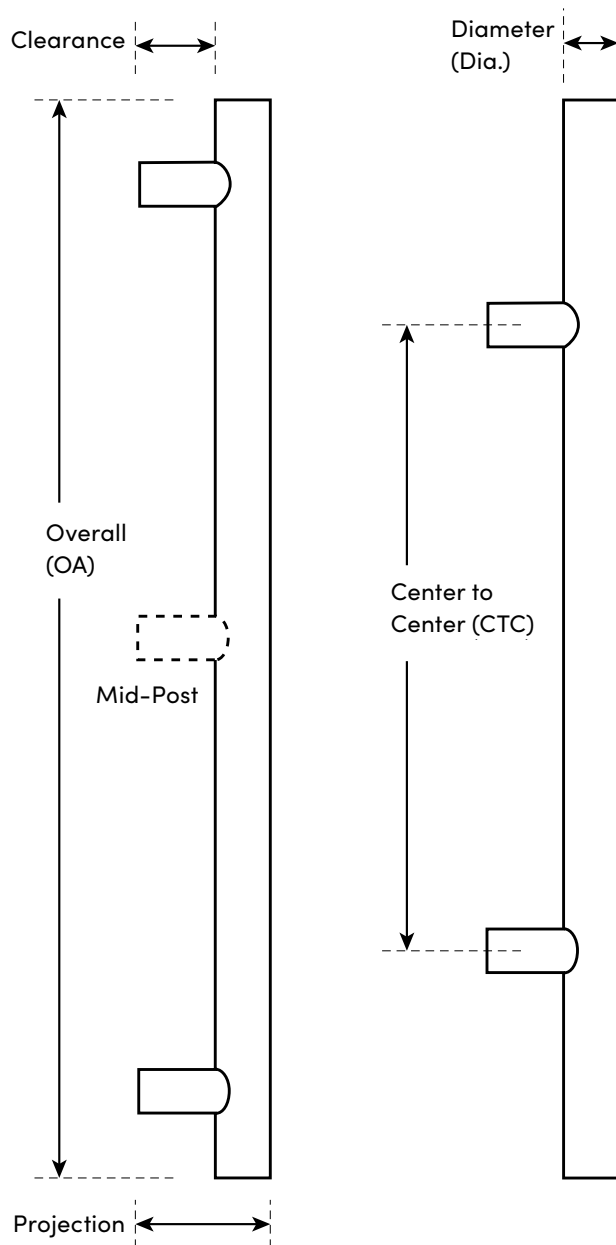

Long door pulls naturally have a small amount of flexing between mounting points that are spaced far apart. The following guidelines will help determine when a mid-post is required, or when altering the location of the mounting posts (by moving them closer together) should be considered to minimize flexing of the grip. A rigid grip is ideal for long door pulls and is particularly important on all glass doors which inherently flex. The mid-post will keep the mechanical joints and fasteners in a sturdy position.

The recommendation for adding a mid-post to long door pulls is based on a theoretical pull load of 30 foot pounds maximum, to open the door. This is a greater than the typical force required to open an average door. The maximum amount of deflection of the grip that might be encountered, is $\frac{3}{8}$ ". The conditions on your job site can vary due to door weight, wind loading, closer settings, locked doors being aggressively pulled, and other circumstances. ASSA ABLOY proposes adding a mid-post to heavy or hard-to-open doors, which will create a more stable and durable installation.

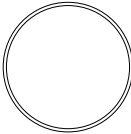

On long pulls, post can be positioned closer to each other and farther away from ends as a strategy to avoid mid-post if door condition permits.

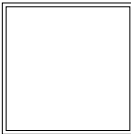
POST MOUNTED PULLS, SHAPES, AND SIZES

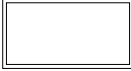
Shape	Material	Material Size	Maximum CTC
	Stainless	1"	70"
	Steel	1 $\frac{1}{4}$ "	90"
		1 $\frac{1}{2}$ "	110"
	Brass/ Bronze	1"	57"
		1 $\frac{1}{4}$ "	73"
		1 $\frac{1}{2}$ "	87"
	Stainless Steel	1" x 1 $\frac{1}{2}$ "	100"
		1" x 1 $\frac{7}{8}$ "	119"
	Stainless Steel	$\frac{3}{4}$ " x 1 $\frac{1}{2}$ "	93"
	Stainless Steel	$\frac{3}{4}$ " x $\frac{3}{4}$ "	62"
	Stainless Steel	$\frac{1}{2}$ " x 1 $\frac{1}{4}$ "	86"
		$\frac{3}{4}$ " x 1 $\frac{1}{2}$ "	110"
	Brass/ Bronze	$\frac{3}{4}$ " x 1 $\frac{1}{2}$ "	89"
	Stainless Steel	$\frac{1}{2}$ " x 1 $\frac{1}{4}$ "	52"
		$\frac{3}{4}$ " x 1 $\frac{1}{2}$ "	75"
	Brass/ Bronze	$\frac{3}{4}$ " x 1 $\frac{1}{2}$ "	60"

* The maximum length of anodized aluminum pulls is 87" due to our tank size. Longer aluminum pulls are available in satin finish and clear coated or powder coat paint.

* The maximum length to powder coat a pull is 118".

* Exception: RM4850 - 1 1/4" Maximum CTC is 60" Brass/Bronze and 84" Stainless Steel.



FASTENING SYSTEMS

Rockwood pulls attach using three basic fastening systems. These mounting systems firmly secure the pull to the door.

Optional base plates can be added for aesthetic or functional purposes. The larger diameter base plates add stability to the fastening system, which is beneficial for glass or wood door applications.

STANDARD MOUNTING DETAILS

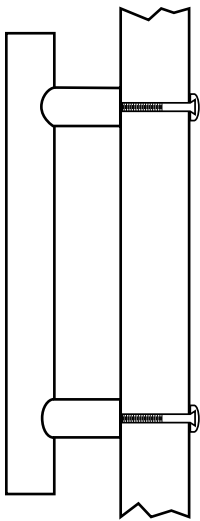

Single Thru Bolt

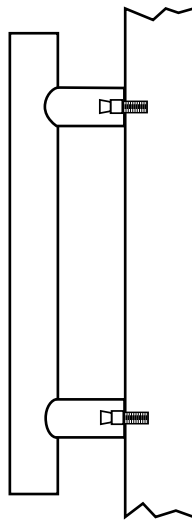

Single Concealed

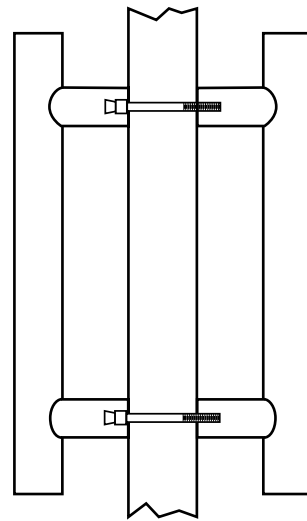

Pair Back to Back

Finishes

Base Material	Aluminum			Bronze						Brass						Stainless Steel					PC			
	US27	US28	311-315	US9	US10	US10B	US10A	US10BL	US20A	US3	US4	US5	US14	US15	US15A	US26	US26D	US32	US32D	US32DMS		US32MS	US32316	US32D316
Part #																								
Tubular (RM201-RM372)	•	•	•	•	•	•	•	•	•	•	•	•						•	•	•	•	•	•	•
Right Angles (RM405-RM413)	•	•	•	•	•	•		•	•	•	•							•	•	•	•	•	•	•
Right Angles (RM415-RM423)				•						•								•		•	•			
Closet Pulls (RM710-RM735)						•	•	•	•	•	•	•	•	•	•	•	•	•	•	•	•	•	•	•
Flush Pulls (RM780-RM785)						•	•	•	•	•	•	•	•	•	•	•	•							•
Flush Pull (RM790)																		•	•	•	•		•	•
Edge Pulls (RM751-RM755)				•	•	•	•	•	•	•	•	•	•	•	•	•	•	•	•	•	•	•	•	•
Edge Pulls (RM760)					•	•	•	•	•	•	•	•	•	•	•	•	•							•
Coat Hooks (RM801-RM804)						•	•	•	•	•	•	•	•	•	•	•	•		•	•	•			•
Coat Hooks (RM805-RM817)					•	•	•		•	•	•	•	•	•	•	•	•			•	•			•
Coat Hooks (RM820-RM823)	•	•	•			•	•			•	•	•						•	•	•	•			•
Coat Hooks (RM828-RM829)	•	•	•			•				•	•	•						•	•	•	•			•
Coat Hooks (RM830-RM843)																		•	•	•	•			•
Door Stops (RM850-RM877)	•	•	•	•	•	•	•	•	•	•	•	•	•	•	•	•	•	•	•	•	•	•	•	•
Push Plates Pull Plates & Signage (RM1010-RM1160W)	•	•	•	•	•	•	•	•	•	•	•	•	•	•	•	•	•	•	•	•	•	•	•	•
MegaTek Small Pulls (RM1200-RM1270)					•	•	•	•	•	•	•	•	•	•	•	•	•	•	•	•	•	•	•	•
Groove Small Pulls (RM1211)					•	•	•	•	•	•	•	•	•	•	•	•	•	•	•	•	•	•	•	•
GripZone - Small Pulls (RM1300-RM1370)										•								•						
NoirMet and ArborMet Small Pulls (RM1410-RM1470) (RM1510-RM1570)					•	•	•	•	•	•	•	•	•	•	•	•	•	•	•	•	•	•	•	•
MegaCurve (RM2000-RM2034)				•	•	•	•	•	•	•	•	•						•	•	•	•	•	•	•
MezzoTek (RM2110-RM2150)	•	•	•	•	•	•	•	•	•	•	•	•						•	•	•	•	•	•	•
NeoMitre Small Pulls (RM1665-RM1675)																		•	•	•	•			•
BandWidth (RM2200-RM2290)					•	•	•	•	•	•	•							•	•	•	•			•
OvalTek (RM2300-RM2420)																		•	•	•	•			•
SoftMet and SoftTek (RM2510-RM2640)				•	•	•	•	•	•	•	•							•	•	•	•			•
NeoMetrix (RM3010-RM3060)				•						•								•		•	•			
Groove (RM3101 & RM3131)	•	•	•	•	•	•	•	•	•	•	•	•	•	•	•	•	•	•	•	•	•	•	•	•
MegaTek (RM3102-RM3342)	•	•	•	•	•	•	•	•	•	•	•							•	•	•	•	•	•	•

Base Material	Aluminum			Bronze					Brass						Stainless Steel					PC				
	US27	US28	311-315	US9	US10	US10B	US10A	US10BL	US20A	US3	US4	US5	US14	US15	US15A	US26	US26D	US32	US32D		US32DMS	US32MS	US32316	US32D316
MegaTek (RM3102-RM3342)	•	•	•	•	•	•	•	•	•	•	•	•						•	•	•	•	•	•	•
NeoMax (RM3202-RM3226 / RM3400-RM3442)				•						•								•			•			
LineaMax (RM3512-RM3782)				•	•	•	•	•	•	•	•	•						•	•	•	•			•
NoirMet (RM3800-RM3854)				•	•	•	•	•	•	•	•	•						•	•	•	•	•	•	•
NoirTek (RM3900-RM3954)	•	•	•	•	•	•	•	•	•	•	•	•	•	•	•	•	•	•	•	•	•	•	•	•
ArborMet and ArborTek (RM4000-RM4190)				•	•	•	•	•	•	•	•	•						•	•	•	•			•
SkewTek (RM4200-RM4274)	•	•	•	•	•	•	•	•	•	•	•	•						•	•	•	•			•
CenTrex (RM4400-RM4516)	•	•	•	•	•	•	•	•	•	•	•	•	•	•	•	•	•	•	•	•	•	•	•	•
AccenTek (RM4700-RM4850)																		•	•		•			•
PlanTek (RM5200, RM5204, RM5280)					•	•	•	•		•	•	•	•	•	•	•	•							•
PlanTek (RM5210-RM5220 / RM5212-RM5222 / RM5232-RM5242 / RM5230-RM5240, RM5270, RM5275, RM5277)	•	•	•	•	•	•	•	•	•	•	•	•	•	•	•	•	•	•	•	•	•	•	•	•
Traditional / Classic (RM5500-RM5670)					•	•	•	•		•	•	•	•	•	•	•	•							•
MariTek (RM5700-RM5702)					•	•	•	•		•	•	•	•	•		•	•							•
English Bridle Leather (RM6060-RM6092)	•	•	•	•	•	•	•	•	•	•	•	•						•	•	•	•	•	•	•
Upholstery Leather (RM6141-RM6192)	•	•	•	•	•	•	•	•	•	•	•	•						•	•	•	•	•	•	•
Leather Oval / Upholstery GeoMetek (RM6200-RM6240) (RM6400-RM6430)																		•	•	•	•			•
Flush Leather (RM6300-RM6354)				•	•	•	•	•	•	•	•	•						•	•	•	•	•	•	•
Small Leather (RM6500-RM6730)					•	•	•	•	•	•	•	•						•	•	•	•			•
NeoCylinder (RM7210-RM7240)																		•	•	•	•			•
Knurled - Grip portion only (RM7501 - RM7511)											•								•	•		•		•
NeoMitre (RM7300-RM7450)																		•	•	•	•			•
GeoMetek (RM7800-RM7960)					•	•	•	•	•	•	•	•	•	•	•			•	•	•	•			•
Locking Door Pulls Post Mount (LP3301)						•	•	•		•	•							•	•	•	•			•
Locking Door Pull NeoTek with GripZone (LP3401)										•								•			•			
Locking Pull English Bridle (LP6061)						•	•	•		•	•							•	•	•	•			•

* Offset Pulls are subject to finish availability.
 ** The maximum length of anodized aluminum pulls is 87" due to our tank size.
 Finishes are subject to availability upon length of pull.

NOTE: Pulls with GripZone offer and additional aesthetic look, not a tactile feel. The grip zones are satin, the post and end sections are polished. US10B finish is not available on GripZone pulls.
 NOTE: Where solid bronze material is not available, we will use a brass as a base material.

The ASSA ABLOY Group is the global leader in access solutions.
Every day, we help billions of people experience a more open world.

ASSA ABLOY Opening Solutions leads the development within
door openings and products for access solutions in homes, businesses
and institutions. Our offering includes doors, frames, door and window
hardware, mechanical and smart locks, access control and service.

ROCKWOOD®

ASSA ABLOY

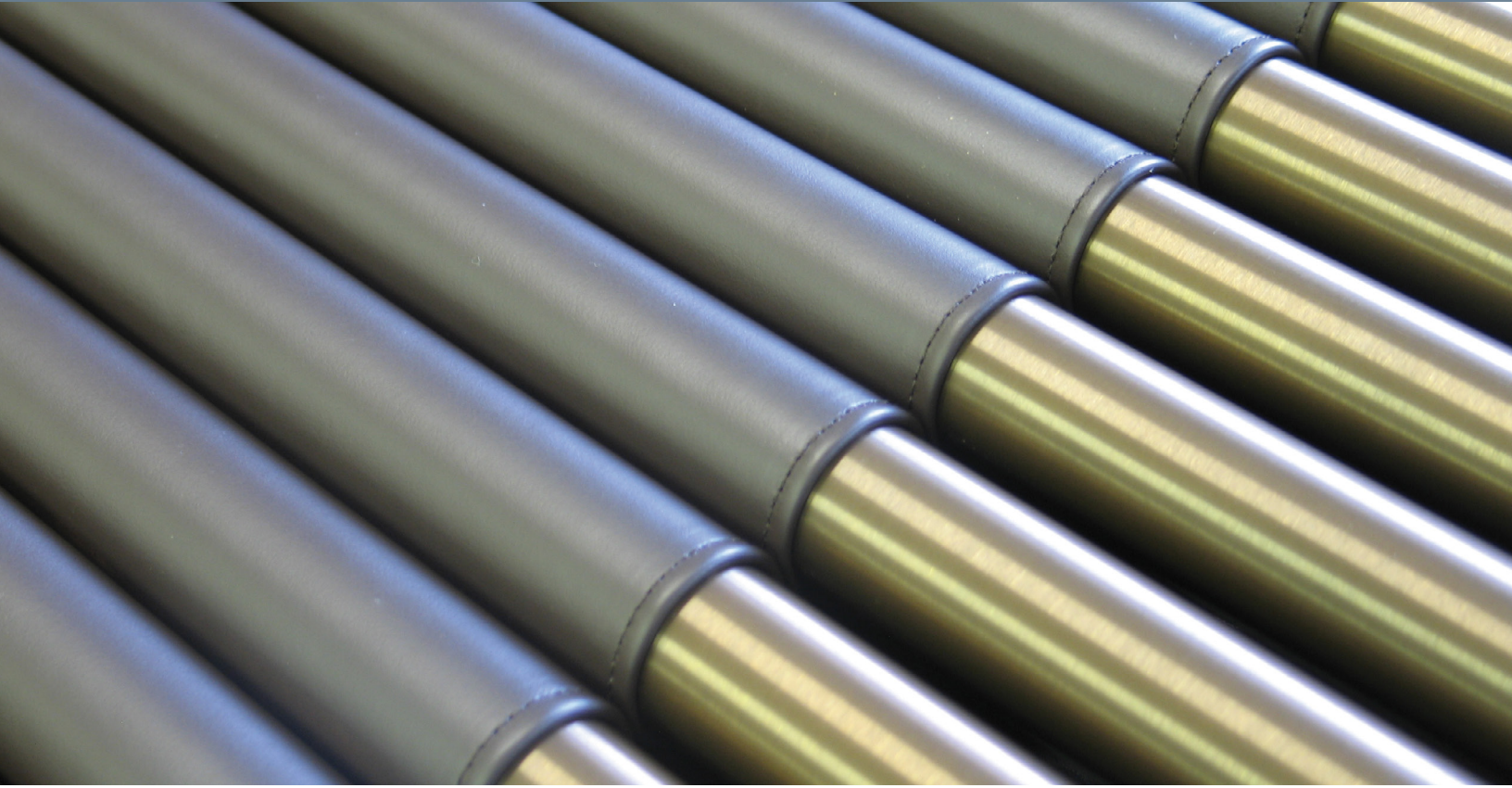

Rockwood Manufacturing Company
300 Main St.
Rockwood, PA 15557
www.rockwoodmfg.com
orders.rockwood@assaabloy.com
1 800 458 2424

Copyright © 2018–2024, ASSA ABLOY Accessories and Door Controls Group, Inc. All rights reserved. Reproduction in whole or in part
without the express written permission of ASSA ABLOY Accessories and Door Controls Group, Inc. is prohibited. Printed in the U.S.A.

RM120 5718.A 7/24