

268, 269 & 278

Concealed Door Closers

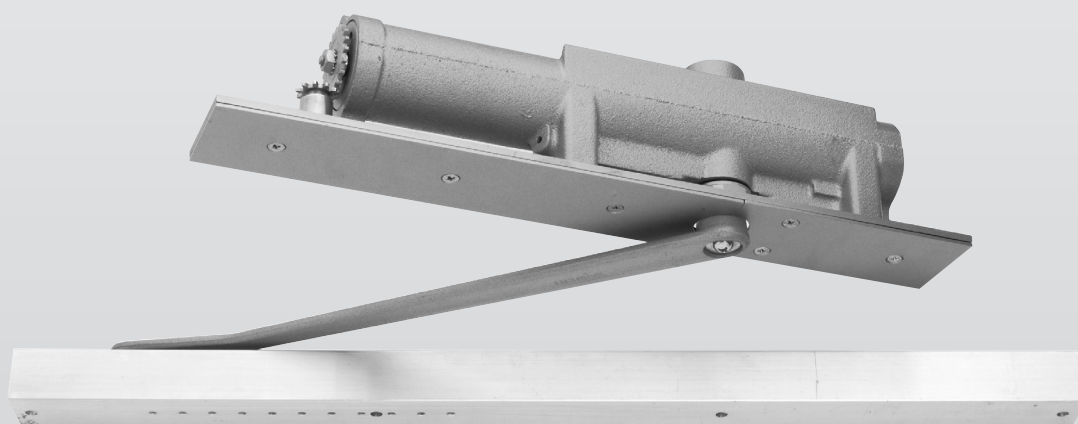

Table of Contents

268, 269 & 278 Concealed Door Closers



General Information 3
 268 Features and Benefits 4
 269 Features and Benefits 5
 268 & 269 Security Packages. 6
 268 & 269 Installation Details 7
 278 Exposed Arm Features and Details. 8
 278 Exposed Arm Installation Details 9
 268, 269 & 278 Special Conditions and How To Order 10
 How to Order a Complete Door Closer 11

The SARGENT line of concealed in frame door closers provide the ultimate in aesthetics and security for door closer installations. Closers are available for interior and exterior applications, overweight doors and for doors that must meet ADA requirements. When security is desired the concealed nature of the 268/269 closer provides a high degree of resistance to abuse since the arm, track and closer is completely concealed when the door is closed. This characteristic also lends itself well to high end architectural openings.

Model	Adjustable Closing Power (BHMA Sizes)	Handed	Arm Type	Delayed Action	Hold open Feature	Application						
268	<table border="1"> <tr> <td>1</td> <td>2</td> <td>3</td> <td>4</td> <td>5</td> <td>6</td> </tr> </table>	1	2	3	4	5	6	Yes	Concealed Track	Option	Optional	Interior Doors
1	2	3	4	5	6							
269	<table border="1"> <tr> <td>1</td> <td>2</td> <td>3</td> <td>4</td> <td>5</td> <td>6</td> </tr> </table>	1	2	3	4	5	6	Yes	Concealed Track	Option	Optional	Exterior or Heavy Interior Doors
1	2	3	4	5	6							
278	<table border="1"> <tr> <td>1</td> <td>2</td> <td>3</td> <td>4</td> <td>5</td> <td>6</td> </tr> </table>	1	2	3	4	5	6	No	Exposed Double Lever	N/A	Option	Exterior or Interior Doors
1	2	3	4	5	6							

ANSI Applications

SARGENT	ANSI
268-O, 269-O	CO5031 & CO5041
268-H	CO5111
268-OB, 269-OB	CO5031 & CO5041
278-H	CO5091
278-O	CO5011

Underwriters’ Laboratories Listing

All SARGENT 268, 269 & 278 Door Closers have been listed by the Underwriters Laboratories, Inc. as follows:

“The SARGENT 268 and 278 door closers can be used on NON-FIRE RATED wood doors.”

“For Self-Closing Doors Without Hold-Open Feature”

Complies with UL 10C Positive Pressure Fire Test.

Any retrofit or other field modification to a fire rated opening can potentially impact the fire rating of the opening, and Sargent Manufacturing Company makes no representations or warranties concerning what such impact may be in any specific situation. When retrofitting any portion of an existing fire rated opening, or specifying and installing a new fire-rated opening, please consult with a code specialist or local code official (Authority Having Jurisdiction) to ensure compliance with all applicable codes and ratings.

On The Cover

- SARGENT 268-O Concealed Door Closer with Standard Arm

Copyright © 2004-2024, SARGENT Manufacturing Company. All rights reserved. Reproduction in whole or in part without the express written permission of SARGENT Manufacturing Company is prohibited. Patent pending and/or patent www.assaabloydss.com/patents.

General Information

268, 269 & 278 Concealed Door Closers

1 Closer Spring Adjustment (not shown)

- Not shown in door closer cycle diagram
- Affects the entire cycle of the door closer movement
- Used to size closer for application requirements (1 through 6)
- Determines the amount of force with which the door closes and the amount of force required to open the door
- Adjustable to compensate for door size and draft conditions

2 Backcheck valve

- At approximately 70° of the open cycle, the Backcheck Valve begins to slow the door's motion
- Prevents the door from slamming into the door's stop
- Valve is used to control the intensity of the Backcheck
- **Note:** A Positive stop is required, Backcheck cannot be used as a stop

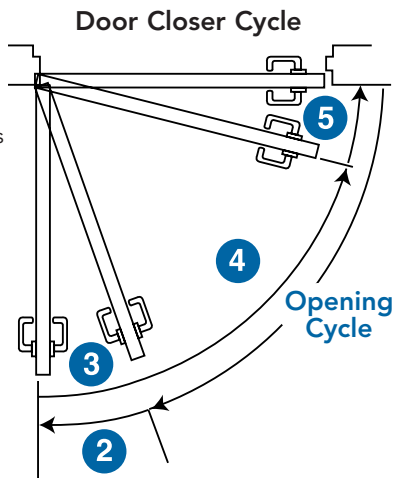

3 Delayed action valve (optional)

- Holds the door in the open position momentarily
- 20 second minimum hold open delay
- Beneficial when moving carts or objects thru door opening

4 Closing speed valve

- Controls how fast the door closes to approximately 8" from the closed position, along with the closer spring

5 Latching speed valve

- Controls the speed of the door during the final 8" of door swing
- The force, the door closes with is controlled by Closer spring
- **Note:** This adjustment is critical for door latching

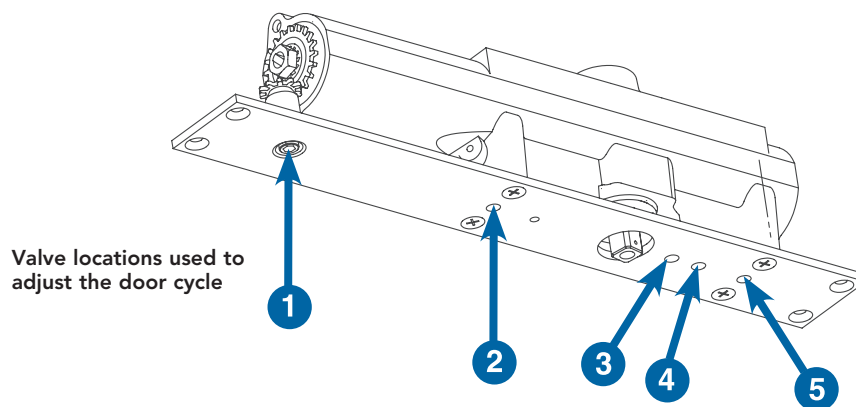

Valve locations used to adjust the door cycle

Suggested Architect's Specification for the 268, 269 & 278 Powerglide® Door Closer

1. All closers for both interior and exterior doors shall be the product of one manufacturer and be matched in style.
2. Full rack and pinion construction.
3. Closing speed, latching speed and backcheck shall be controlled by key operated valves.
4. Delayed action feature shall be available and controlled by a separate valve. Delayed action shall be available in addition to, not in lieu of, backcheck. (Not available with 278 Closers).
5. The one piece closer body shall be of close grained porous free cast iron.
6. An increase of 15% in closing power shall be provided by means of adjustment of the arm leverage at the foot connection. (278 Only).
7. All arms shall be finely finished with heavy duty forged steel main arm.
8. The spindle shaft shall be sealed hydraulically with an "O" ring.
9. The 268, 269 door closer shall be mounted overhead and concealed with no exposed surfaces when door is in closed position.
10. The 278 closer shall have a fully overhead concealed body with exposed forged steel arm.
11. Closers should have two pressure relief valves standard (opening and closing cycles).
12. All closers to have a 10 year limited warranty.
13. Closers comply with UL 10C Positive Pressure Fire Test (for hollow metal door and frames only).

268 Features and Benefits

268, 269 & 278 Concealed Door Closers

The SARGENT 268 Door Closer provides security and aesthetics by completely hiding the door closer, track and arm in the door and frame.

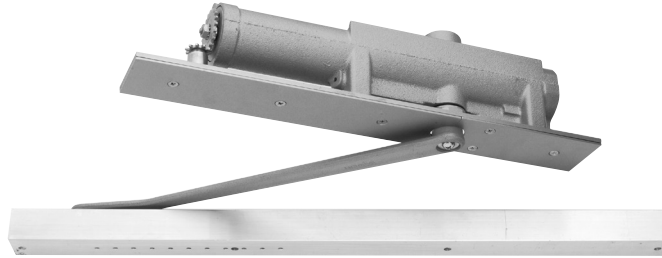

268 Features and Benefits

Strength & Durability	Aesthetics & Flexibility	Security
<ul style="list-style-type: none"> • Conforms with Standard UL 10C for positive pressure fire test • UL and cUL Listed for use on fire doors having a rating up to and including 3 hours (hollow metal frames and doors only - no wood doors) • 10 Year warranty • One piece cast iron body • 1-1/2" dia. piston for superior door control • Heat treated spindle and piston for years of reliable service • Captivated brass valves provide easy door control while preventing accidental valve removal 	<ul style="list-style-type: none"> • Powder coated and plated finishes available to match SARGENT door trim • Concealed track, arm and closer • Closing force adjustable through a range of BHMA sizes • Optional hold open and bumper features available • All-weather fluid allows closer to operate properly in extreme cold and hot environments without readjustment 	<ul style="list-style-type: none"> • Heavy duty forged steel arm • Concealed in-frame design inhibits possible tampering • Security screws available • Concealed door position switch available • Pressure relief valves allow closer to absorb abusive forces, preventing damage to doors and frames

Product Details for 268

- Fully concealed closer body concealed in the frame head
- Track fully concealed in door. Arm is only visible when door is open
- 1-3/4" (44mm) min. door thickness
- Arms are forged steel with bearing roller
- Aluminum track
- Metal closer faceplate furnished standard
- Handed - Order the same hand as the door
- Closing force adjustable 2 through 4
- Closers are factory preset for 3' door width
- Delayed action option available
- Auxiliary door stop required
- Door weights - up to 250 lbs.

Finishes

Finishes	ANSI/BHMA	Description
4	606	Satin brass, clear coated
10B	613	Dark oxidized satin bronze, oil rubbed
10BE	613E	Dark oxidized satin bronze - equivalent
14	618	Bright nickel plated, clear coated
15	619	Satin nickel plated, clear coated
26D	626	Satin chromium plated
BSP	—	Black Suede Powder Coat
WSP	—	White Suede Powder Coat
EN	689	Aluminum sprayed or powder coated
EP	691	Bronze sprayed or powder coated to match 10
EB	695	Bronze sprayed or powder coated to match 10B
EAB	696	Brass sprayed or powder coated

Available Arms

Arm Type	Max Door Opening	Degree of Hold Open or Stop
O - Standard Arm	180°	N/A
OB - Standard Arm with Bumper to assist backcheck	140°	140°
H - Hold Open Arm	110°	85°-110°
HB - Hold Open Arm with Bumper to assist back-check	110°	110°

Note: Rubber bumper in the track is to assist backcheck in light-duty interior applications only

269 Features and Benefits

268, 269 & 278 Concealed Door Closers

The SARGENT 269 Door Closer provides an ideal solution when a concealed door closer is required on heavy large doors opening to 180°. The closer is specially designed to provide strong closing power at opening angles beyond 100° when many concealed closers lose power.

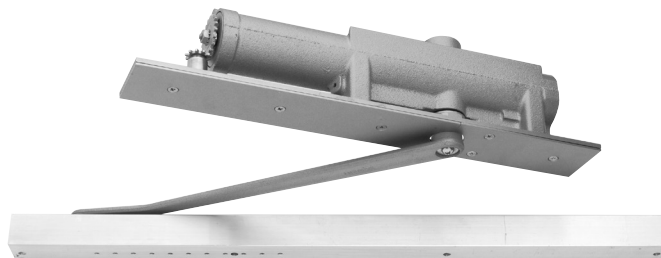

269 Features and Benefits

Strength & Durability	Aesthetics & Flexibility	Security
<ul style="list-style-type: none"> Conforms with Standard UL 10C for positive pressure fire test UL and cUL Listed for use on fire doors having a rating up to and including 3 hours (hollow metal frames and doors only - no wood doors) 10 Year warranty One piece cast iron body 1-1/2" dia. piston for superior door control Double heat treated spindle and piston for years of reliable service Captivated brass valves provide easy door control while preventing accidental valve removal 	<ul style="list-style-type: none"> Powder coated and plated finishes available to match SARGENT door trim Concealed track, arm and closer Closing force adjustable through a range of BHMA sizes Optional bumper features available All-weather fluid allows closer to operate properly in extreme cold and hot environments without readjustment 	<ul style="list-style-type: none"> Heavy duty forged steel arm Concealed in-frame design inhibits possible tampering Security screws available Concealed door position switch available Pressure relief valves allow closer to absorb abusive forces, preventing damage to doors and frames

Product Details for 269

- Specially designed spring to close heavy doors
- Fully concealed closer body concealed in the frame head
- Track fully concealed in door. Arm is only visible when door is open
- 1-3/4" (44mm) min. door thickness
- Arms are forged steel with bearing roller
- Aluminum track
- Metal closer faceplate furnished standard
- Handed - Order the same hand as the door
- Closing force adjustable from size 4 to 5
- Delayed action option available
- Auxiliary door stop required
- Removable stop required for door widths under 2"
- Door weights - up to 250 lbs.

Finishes

Finishes	ANSI/BHMA	Description
4	606	Satin brass, clear coated
10B	613	Dark oxidized satin bronze, oil rubbed
10BE	613E	Dark oxidized satin bronze - equivalent
14	618	Bright nickel plated, clear coated
15	619	Satin nickel plated, clear coated
26D	626	Satin chromium plated
BSP	—	Black Suede Powder Coat
WSP	—	White Suede Powder Coat
EN	689	Aluminum sprayed or powder coated
EP	691	Bronze sprayed or powder coated to match 10
ED	693	Black sprayed or powder coated to match 10B
EB	695	Bronze sprayed or powder coated to match 10B
EAB	696	Brass sprayed or powder coated

Available Arms

Arm Type	Max Door Opening	Degree of Hold Open or Stop
O - Standard Arm	180°	N/A
OB - Standard Arm with Bumper to assist back-check	140°	140°

Note: Rubber bumper in the track is to assist backcheck in light-duty interior applications only

268 & 269 Security Packages

268, 269 & 278 Concealed Door Closers

SARGENT
ASSA ABLOY

The SARGENT concealed closer security packages provide a vandal-resistance design ideal for correctional institutions and other abusive environments. Both the 268 and 269 closer bodies are available with security packages.

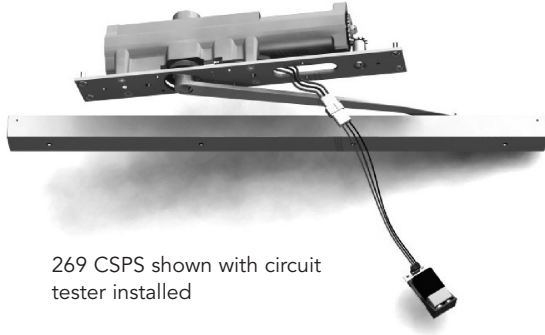

269 CSPS shown with circuit tester installed

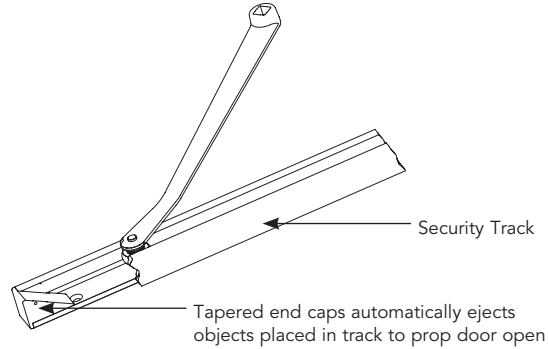

Security Packages***

CSP - Closer Security Pack

- Includes security track that automatically ejects foreign material
- Heavy duty steel cover plate protects adjusting valves from possible tampering
- Tamper resistant security screws provided for track and closer cover plate
- Requires different templating from standard 268 or 269

CSPS - Closer Security Pack with Switch

- Same as CSP with a field adjustable single pole double throw Door Position Switch to interface with security and alarm systems
- Contacts are rated at 120/250VAC, 10.1 amp resistive load
- Switch equipped with a 3 wire color coded 12" 18 gauge wire harness
- Switch contact point can be adjusted without removing closer from frame

CSPD - Closer Security Pack with Double Switch

- Same as CSPS except a double pole, double throw switch is included with two 3 wire color coded 12" 18 gauge Wire Harness
- Contacts are rated at 120/250VAC, 10.1 amp resistive load
- Switch contact point can be adjusted without removing closer from frame

Circuit Tester

A battery powered Circuit Tester is available to verify the switch contact point at the door location without removing the closer from the frame. The switch is connected to the closer through a slot provided on all SARGENT CSPS and CSPD closers.

The Circuit Tester is ordered as part # 63-4335.



Extended Wiring Harness

An 84" Extended Wiring Harness is available to incorporate the closer's security pack into the buildings security.

The Extended Wiring Harness is ordered as part # 63-4332

Note: CSPD requires two harnesses (63-4332), one for each switch

Copyright © 2004-2024, SARGENT Manufacturing Company. All rights reserved. Reproduction in whole or in part without the express written permission of SARGENT Manufacturing Company is prohibited. Patent pending and/or patent www.assaabloydss.com/patents.

*** Delayed Action option is not available with 268, 269 & 278 Closers with the Security Packages (CSP, CSPS & CSPD)

268 & 269 Installation Details

268, 269 & 278 Concealed Door Closers

SARGENT
ASSA ABLOY

268 2" Face Frame Installation

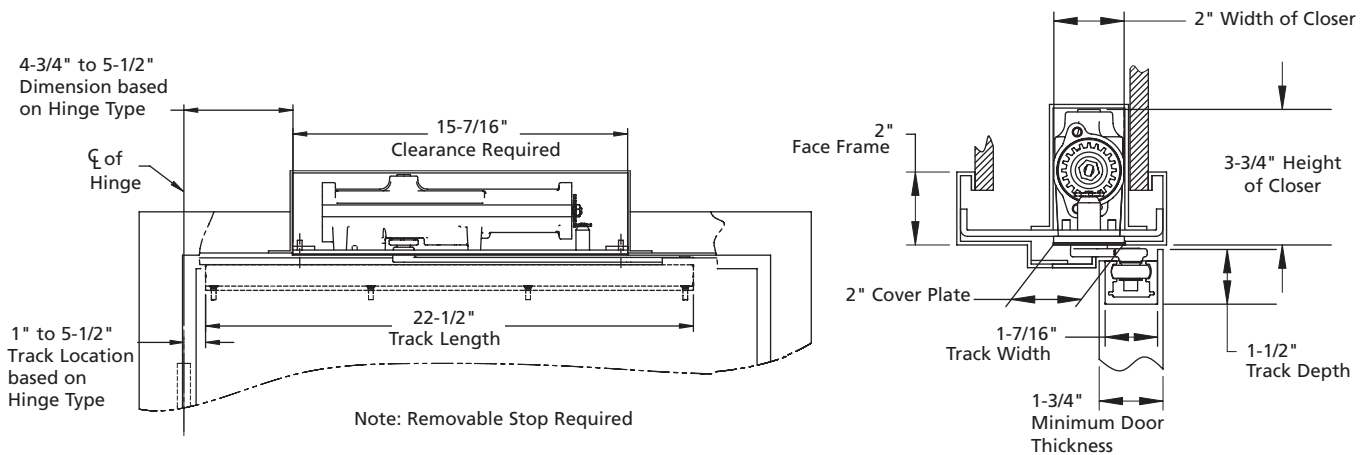

268/269 CSP/CSPS/CSPD 4" Face Frame & 2" Door Installation Details (Security Track Shown)

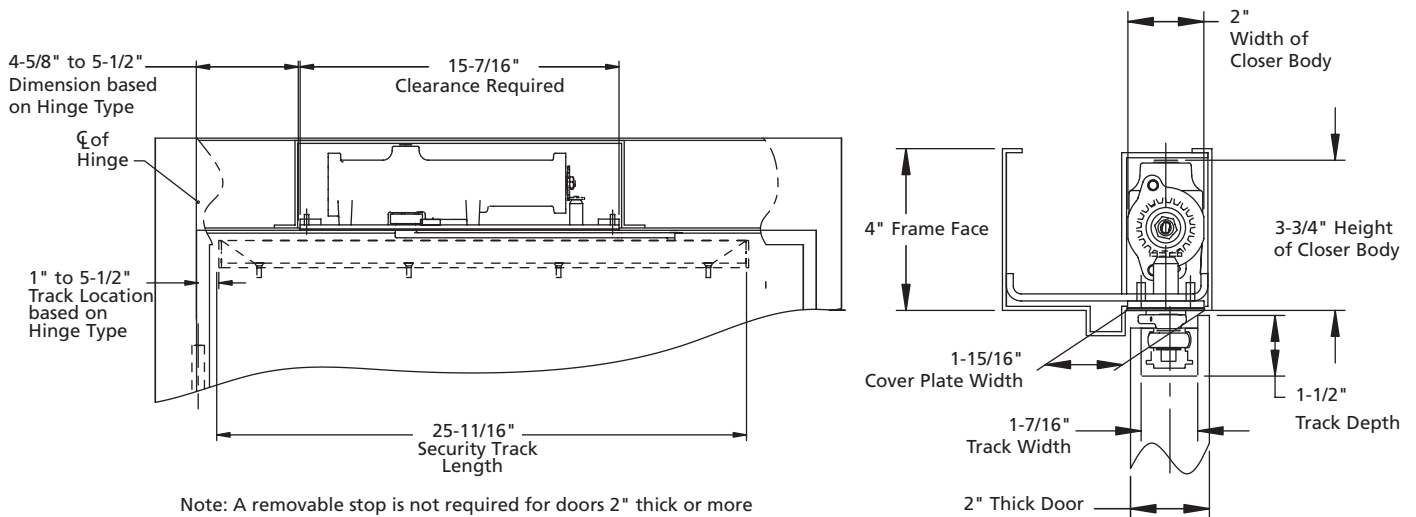

Copyright © 2004-2024, SARGENT Manufacturing Company. All rights reserved. Reproduction in whole or in part without the express written permission of SARGENT Manufacturing Company is prohibited. Patent pending and/or patent www.assaabloydss.com/patents.

278 Exposed Arm Features and Benefits

268, 269 & 278 Concealed Door Closers

SARGENT
ASSA ABLOY

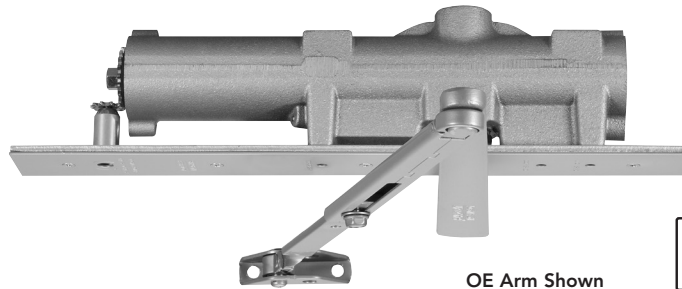

OE Arm Shown

278 Features and Benefits

Strength & Durability	Aesthetics & Flexibility	Security
<ul style="list-style-type: none"> Conforms with Standards UL 10C "Positive Pressure Fire Tests of Door Assemblies" One piece cast iron body 1-1/2" dia. piston for superior door control Heat treated spindle and piston for years of reliable service Captivated brass valves provide easy door control while preventing accidental valve removal 	<ul style="list-style-type: none"> Powder coated and plated finishes available to match SARGENT door trim Closing force adjustable through a range of BHMA sizes Optional hold open feature available Adjustable to meet ADA requirements All weather fluid allows closer to operate properly in extreme cold and hot environments without readjustment 	<ul style="list-style-type: none"> Forged steel main arm Concealed in-frame design inhibits possible tampering Security screws available Pressure relief valves allow closer to absorb abusive forces, preventing damage to doors and frames

ADA Compliance: Door closers, adjusted to meet ADA conditions or other reduced opening force requirements, may lack adequate closing power to properly latch a door when draft or other conditions exist.

Product Details for 278

- ADA compliant
- Semi Concealed: Closer body concealed in frame head and closer arm attaches to the surface of the door face
- Removable stop required (supplied)
- Closer faceplate furnished
- Arm assembly are forged and wrought steel
- Handed - Order the same hand as the door
- Closing force adjustable 1 thru 6
- Suitable for interior doors up to 5' wide
- Suitable for exterior doors up to 4' wide
- Closers are factory preset for 3' door width
- Closers can be factory preset upon request
- Auxiliary door stop required
- Door weights - up to 250 lbs.

Finishes

Finishes	ANSI/BHMA	Description
EN	689	Aluminum sprayed or powder coated
EP	691	Bronze sprayed or powder coated to match 10
EB	695	Bronze sprayed or powder coated to match 10B
EAB	696	Brass sprayed or powder coated
BSP	—	Black Suede Powder Coat
WSP	—	White Suede Powder Coat

Available Arms

Arm Type	Max Door Opening	Degree of Hold Open or Stop
O - Standard Arm	180°	N/A
H - Hold Open Arm	110°	85° – 110°

Copyright © 2004-2024, SARGENT Manufacturing Company. All rights reserved. Reproduction in whole or in part without the express written permission of SARGENT Manufacturing Company is prohibited. Patent pending and/or patent www.assaabloydss.com/patents.

90118 04/24

278 Exposed Arm Installation Details

268, 269 & 278 Concealed Door Closers

278 Door Closer

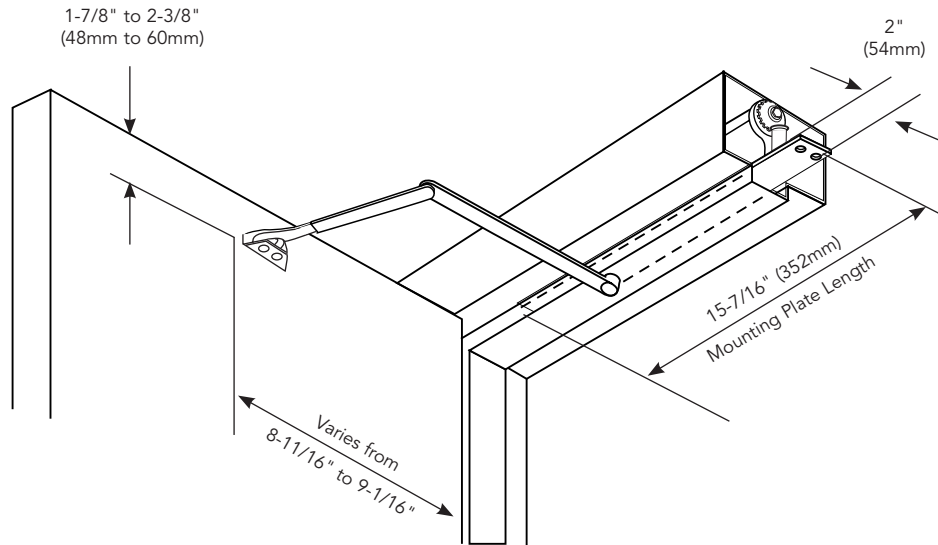

Single Rabbeted Frame Shown

Double Rabbeted Frame Shown

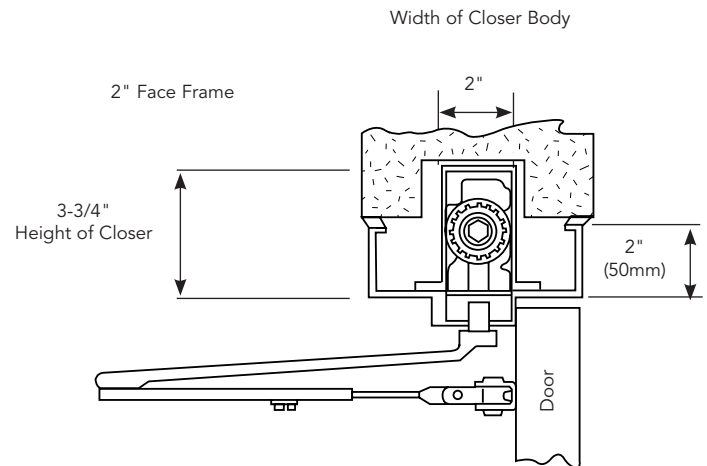
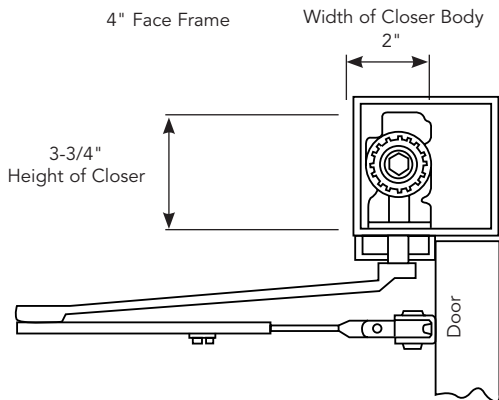

Available Arms

OE - Standard Arm

- Regular 278 arm
- Non-handed



Includes: 63-4430 - Main arm
63-2216 - Foot assembly
63-3640 - Screw pack

278-H Holder Arm

- Adjustable friction holder
- Non-handed
- Permits 180° door opening

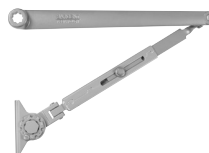

For arm only, order 25-H
Includes: 63-2229 - Main arm
61-2303 - Foot assembly
63-3642 - Screw pack

Copyright © 2004-2024, SARGENT Manufacturing Company. All rights reserved. Reproduction in whole or in part without the express written permission of SARGENT Manufacturing Company is prohibited. Patent pending and/or patent www.assaabloydss.com/patents.

268, 269 & 278

Special Conditions and How To Order

268, 269 & 278 Concealed Door Closers



Special Conditions

Standard templates are available on the SARGENT website. For special applications, consult SARGENT technical services.

Series	Number per Carton	Approx. wt per Carton
268, 269 & 278	1-Standard	10 lbs.

Fastener Options: Optional 6 lobe screws. Specify 36- Option

Spray Paint

Touch up spray paint available in the following colors: EB, ED, EN, EP, EAB

Special Rust Inhibitor Process (SRI-)

Additional process for closer body provides extra layer of protection for extreme corrosive environments.

Not available with plated finishes.

278 Series, Through Bolts and Mortise Nuts

- Through-bolts are available. Specify TB- option for 1-3/4" (44mm) thick doors; for thicker doors, specify 31-TB- include door thickness
- Through-bolting for 2-1/4" (57mm) thick hollow metal doors require bridge type reinforcement to prevent collapse of top rail when through-bolts are tightened

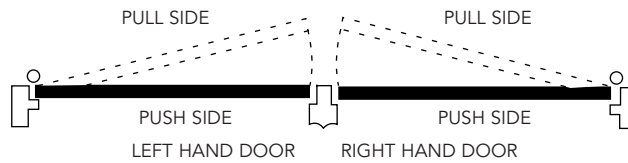

How To Order Closer Body Only

For 268 Closer Body only	Specify: CB-268 x hand
For 269 Closer Body only	Specify: CB-269 x hand
For 278 Closer Body only	Specify: CB-278 x hand

How To Order a Complete Door Closer

268, 269 & 278 Concealed Door Closers

How To Order a Complete Door Closer

		36- Options	268 Closer	H Arm	26D Finish	RH Hand
Options						
36-	6-Lobe Screws (Security Torx - Machine Screws Only)	<input type="checkbox"/>				
DA-	Delayed Action***	<input type="checkbox"/>				
SRI-	Corrosion Protection - Closer Body Only	<input type="checkbox"/>				
TB-	Through Bolts - (278 Only)	<input type="checkbox"/>				
Door Closer Series						
268	Concealed Closer 2-4	<input type="checkbox"/>				
269	Concealed Closer 4 & 5	<input type="checkbox"/>				
278	Concealed Closer 1-6	<input type="checkbox"/>				
Arms/Tracks						
O	Standard Arm (268 & 269)	<input type="checkbox"/>				
OE	Standard Arm (278)	<input type="checkbox"/>				
H	Hold Open Arm (268 & 278)	<input type="checkbox"/>				
OB	Std Arm & Bumper (268 & 269)	<input type="checkbox"/>				
HB	Hold Open Arm With Bumper (268)	<input type="checkbox"/>				
CSP	Security Track (268 & 269)	<input type="checkbox"/>				
CSPS	Security Track w/ Switch (268 & 269)	<input type="checkbox"/>				
CSPD	Security Track w/ 2 Switches (268 & 269)	<input type="checkbox"/>				
Finish						
EB	Bronze Enamel To Match 10B	<input type="checkbox"/>				
ED	Black Enamel To Match 20D	<input type="checkbox"/>				
EN	Aluminum Enamel	<input type="checkbox"/>				
EP	Bronze Enamel To Match US10	<input type="checkbox"/>				
EAB	Brass Enamel To Be Used With Brass Finishes	<input type="checkbox"/>				
04	Satin Brass with Clear Powder Coat	<input type="checkbox"/>				
10B	Oxidized Satin Bronze, Oil Rubbed	<input type="checkbox"/>				
26D	Satin Chrome	<input type="checkbox"/>				
BSP	Black Suede Powder Coat	<input type="checkbox"/>				
WSP	White Suede Powder Coat	<input type="checkbox"/>				
Hand						
RH	Right Hand	<input type="checkbox"/>				
LH	Left Hand	<input type="checkbox"/>				

*** Delayed Action not available with 278 closers

*** Delayed Action not available with 268 & 269 with security packages (CSP, CSPS & CSPD)

The ASSA ABLOY Group is the global leader in access solutions. Every day, we help billions of people experience a more open world.

ASSA ABLOY Opening Solutions leads the development within door openings and products for access solutions in homes, businesses and institutions. Our offering includes doors, frames, door and window hardware, mechanical and smart locks, access control and service.



SARGENT Manufacturing Company
100 Sargent Drive
New Haven, CT 06511 USA
800-727-5477
www.sargentlock.com

Founded in the early 1800s, SARGENT® is a market leader in locksets, cylinders, door closers, exit devices, electro-mechanical products and access control systems for new construction, renovation, and replacement applications. The company's customer base includes commercial construction, institutional, and industrial markets.

Copyright © 2004-2024, SARGENT Manufacturing Company. All rights reserved. Reproduction in whole or in part without the express written permission of SARGENT Manufacturing Company is prohibited. Patent pending and/or patent www.assaabloydss.com/patents.