

FM6100 Series

Multi-Point Lock for Shutters

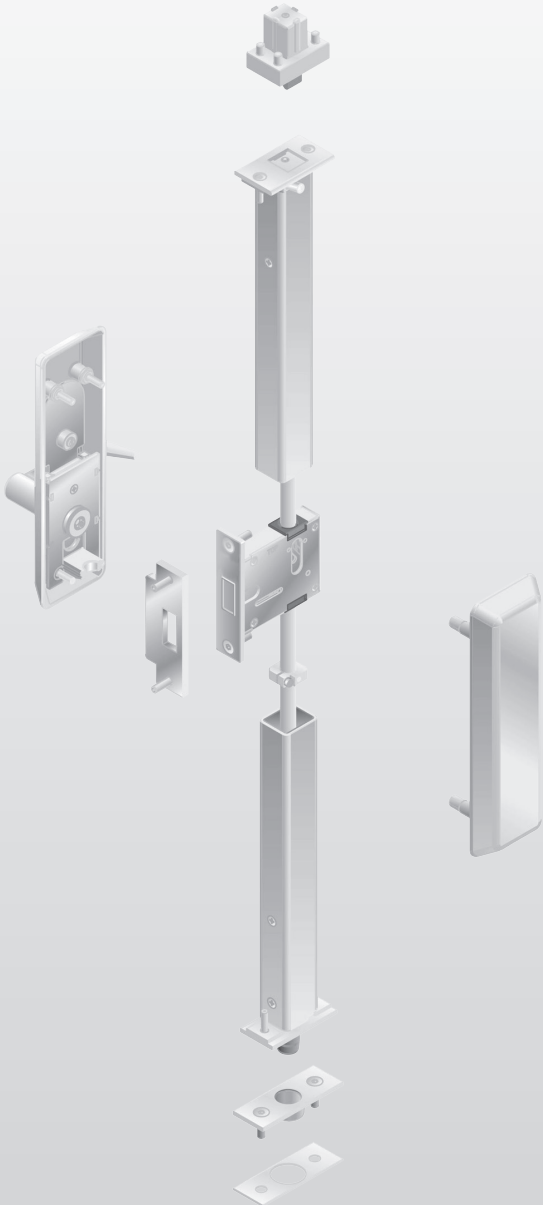

Table of Contents

Multi-Point Auto Deadlocking Shutter System

Introduction & Features	3
Windstorm: UL & Florida Certifications	4
FM6100 Specifications	5
Functions & Descriptions	6
EC Trim, Finishes, Standard & Coastal Series Levers	7
Studio Collection Levers	8-10
Mechanical & Cylinder Options	11
Cylinder Options	12
FM6100: How to Order & Architectural Specification	13



The Agion antimicrobial is not intended as a substitute for good hygiene. Coated products must still be cleaned to ensure the surfaces will be free of destructive microbes. ASSA ABLOY makes no representations or warranties, express or implied, as to the efficacy of the Agion antimicrobial. A copy of the Agion warranty is available upon request. Agion is a registered trademark of Agion Technologies, Inc., Wakefield, MA, USA.

MicroShield®

ASSA ABLOY Group companies offer MicroShield®, an antimicrobial coating for door hardware. MicroShield® uses proven silver ion-based technology from Agion®, a leading provider of antimicrobial solutions, to stem the spread of bacteria and other microbes.

MicroShield® is a trademark of ASSA ABLOY Access and Egress Hardware Group, Inc.

MicroShield® Coating

Revolutionary finish coating available on all SARGENT product lines, utilizes a silver-based antimicrobial compound from Agion Technologies

As an integral part of the finish coating, MicroShield® lasts for the life of the hardware

MicroShield® coating permanently suppresses the growth of bacteria, algae, fungus, mold and mildew. It is effective against a broad spectrum of bacteria.

Non-toxic and completely safe. The Agion antimicrobial compound is EPA and NSF approved and FDA listed for use in medical and food preparation equipment.

Applications: Anywhere there is need for a clean environment (hospitals, laboratories, schools, medical centers, daycare, food processing etc.)

Introduction & Features

Multi-Point Auto Deadlocking Shutter System

The SARGENT FM6100 Series is a multi-point auto deadlocking system developed to help protect lives while securing a community shelter or safe room entry. Sturdy heavy-duty steel components firmly secure the door or storm shutter within the frame – at top, bottom and center latch points – securing the opening during a windstorm event. The FM6100 is UL Classified to FEMA P-320 (2014), FEMA P-361 (2015) and ICC 500 (2014). This device consists of concealed vertical rods with a top and bottom latching complemented by an automatically projecting deadbolt at the center of the shutter. The device is operated by dual mounted EC controls (similar to the 80 Series ET Controls).

The EC control operates by pushing the top bolt out of the door or storm shutter and into the frame while retracting the bottom bolt and deadbolt simultaneously. Once retracted the bolts are held in position as the storm shutter swings. As the locking system closes, the hold back feature engages the frame: all bolts project simultaneously. Once secured, the occupants are protected against threatening conditions.

EC controls are available with a variety of functions which include classroom and passage x blank plate. All FM6100 devices are UL Listed to applicable 3 hour fire standards.

The FM6100 Series is a heavy-duty multi-point auto deadlocking system joining the SARGENT line of multi-point security devices including:

- Center & Top Latching Exit Devices which incorporate a mortise lock and top latching vertical rods

Innovation

- Unique and robust multi-point auto deadlocking system engineered to help save lives

FM6100 Series

- **Fully integrated – FM6100 Series is part of a complete ASSA ABLOY severe windstorm solution requiring CECO DOOR and CURRIES StormPro® shutters, and McKINNEY® StormPro® hinges**

- UL Classified to FEMA P-320 (2014), FEMA P-361 (2015) and ICC 500 (2014) for inswing and outswing shutters 2'8" w x 3'0" h minimum to 4'0" w x 6'8" h maximum.

Applications

- Perfect for community refuge areas – where people seek protection from strong wind events
- Community shelters and safe rooms, corporate campuses, K-12 schools, healthcare facilities and government facilities

Strength & Durability

- UL Listed 3-hour fire rating
- Extra-heavy duty steel components automatically secure the shutter to the frame
 - In multiple locations: top, bottom and center latch points
 - Fortifies opening to withstand extreme wind speeds and flying debris
- Heavy duty escutcheons standard
- Fortified with high tensile alloy Holo-Krome® fasteners
- Through-bolts on shutter for solid attachment

Features

All latching points activate automatically when shutter is closed and retract with one single motion upon exit

- Both inswing and outswing applications
- Solid cast levers

Three functions available:

- Passage Lever x Blank Plate
- Classroom
- Seven year limited warranty

Windstorm: UL Certifications

Multi-Point Auto Deadlocking Shutter System



Windstorm Certifications: UL Listings

Listed below are certifications and standards met by the FM6100 Multi-Point Auto Deadlocking System.

UL Certification Directory: ZHLL.R21744 – Products for Use in Windstorm-rated Assemblies

Certifications to meet assembly requirements are done in conjunction with doors from ASSA ABLOY Group companies CECO DOOR and CURRIES.

FEMA Publication 320 (2014)	"Taking Shelter From the Storm: Building a Safe Room for Your Home or Small Business", investigated with respect to impact and pressure requirements only
FEMA Publication 361 (2015)	"Design and Construction Guidance for Community Safe Rooms", investigated with respect to impact and pressure requirements only
ICC 500 -2014	"ICC/NSSA Standard for the Design and Construction of Storm Shelters", investigated with respect to impact and pressure testing. Minimum missile impact speeds vary with the design wind speed desired for a particular product. The information below correlates design wind speed to the minimum missile speeds as discussed in Table 305.1.1 of ICC 500

Note: Any retrofit or other field modification to a fire or windstorm rated opening can potentially impact the rating of the opening, and Sargent Manufacturing Company makes no representations or warranties concerning what such impact may be in any specific situation. When retrofitting any portion of an existing fire or windstorm rated opening, or specifying and installing a new fire or windstorm rated opening, please consult with a code specialist or local code official (Authority Having Jurisdiction) to ensure compliance with all applicable codes and ratings.

Copyright © 2007-2023, SARGENT Manufacturing Company. All rights reserved. Reproduction in whole or in part without the express written permission of SARGENT Manufacturing Company is prohibited. Patent pending and/or patent www.assaabloyds.com/patents.

FM6100 Specifications

Multi-Point Auto Deadlocking Shutter System

5/8" stainless steel latch housing through-hardened steel latchbolt, 3/4" projection 1/4-20 steel Holo-Krome® mounting screws

1/8" thick, through-hardened steel front; 5/16-18 steel Holo-Krome® mounting screws

11 gauge steel 12" top bolt reinforcement

Mortised centerbolt utilizes a one-piece stainless steel, 19/32" x 1-1/4" x 1" throw bolt, 3/16" thick stainless steel front, steel case & cap

1/8" steel reinforcement plate 3/4" steel nylon coated lower bolt, 3/4" projection

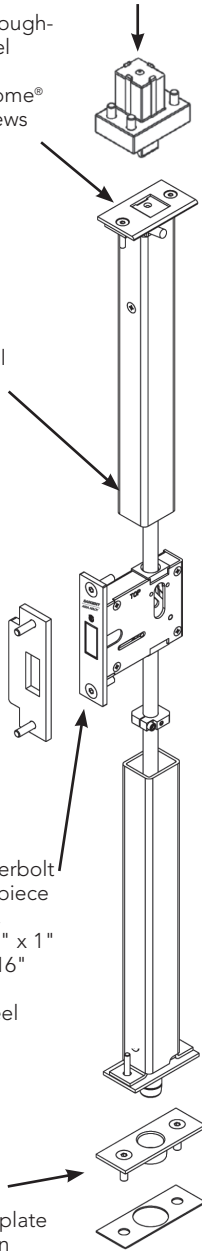

Features

- **FM6100 is part of a complete ASSA ABLOY severe windstorm solution requiring CECO DOOR StormPro® 361, CURRIES StormPro® 361, and McKINNEY® hinges**
- Meets FEMA P-320 (2014), FEMA P-361 (2015) and ICC 500 (2014) for inswing and outswing shutters
- Concealed rods offer additional security
- All functions determined by outside trim

Specifications

For Shutters	1-3/4" thick Shutter only; Fully integrated – FM6100 Series is part of a complete ASSA ABLOY windstorm solution requiring CECO DOOR StormPro® 361, CURRIES StormPro® 361, and McKINNEY® hinges
Mounting	Supplied fasteners are for metal doors with through-bolts for trim
Hand	Handed; specify RH or LH, see chart below
Top Bolt	Hardened steel with 7/8" projection in a 5/8" stainless steel housing projecting from the frame
Bottom Bolt	Steel 3/4" diameter with 3/4" projection with 1/8" steel plate
Center Bolt	One-piece stainless steel, 19/32" x 1-1/4" x 1" throw
Lock Front	1-1/8" x 4-7/8" x 3/16" thick stainless steel, one piece
Center Bolt Strike	1/4" thick stainless steel
Backset	2-3/4" standard
Shutters Thickness	1-3/4" standard
Sizes	Single shutters - Minimum 2'6" x 3'0" - Maximum 4'0" x 6'8" Pair of Shutters - Minimum 5'0" x 4'0" - Maximum 8'0" x 6'8"
Shutter Swing	Inswing or outswing
Trim	EC trim with Standard, Coastal Series or Studio Collection levers
Functions	<ul style="list-style-type: none"> • Passage Lever x Blank Plate (standard) • Classroom
Cylinder	#41 Mortise Cylinder

Functions and Descriptions

Multi-Point Auto Deadlocking Shutter System

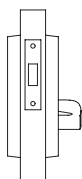
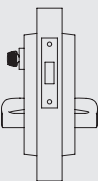

How to Order		Outside EC Function		Inside EC Function	
Product Designation	SARGENT Function Numbers	Outside Function Description		SARGENT Function Numbers	Inside Function Description
FM6101	01	<ul style="list-style-type: none"> • Multi-point auto deadlocking system • Multi-point latch retraction by inside lever • Lever on one side, blank plate on the other • Lever always free • For inswing and outswing storm shutters 		15	Inside Passage
FM6113	13	<ul style="list-style-type: none"> • Multi-point auto deadlocking system • Multi-point latch retraction by lever either side, unless outside lever is locked by key outside • Inside lever always free 		15	Classroom

Note: Product designation is determined by function of outside trim. The inside trim is always 15 function, which allows for free egress. Function combinations not shown may be available as a special. Consult factory.

Copyright © 2007-2023, SARGENT Manufacturing Company. All rights reserved. Reproduction in whole or in part without the express written permission of SARGENT Manufacturing Company is prohibited. Patent pending and/or patent www.assaabloyds.com/patents

EC Trim, Finishes, Standard & Coastal Series Levers

Multi-Point Auto Deadlocking Shutter System

EC Lever Controls

The trim for the FM6100 Series is the EC Control which mounts on each side of the shutter. The outside EC Control determines the function of the entire device. The inside EC Control provides a passage function. Easy operating lever handle allows convenient one hand operation. Decorative Coastal Series Levers and Studio Collection levers are available. All levers are brass. For stainless steel levers consult factory.

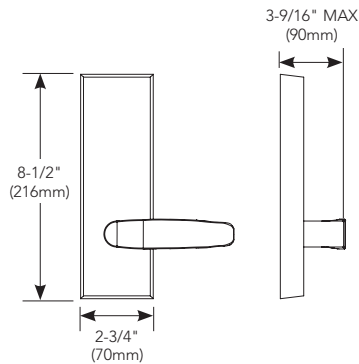

SARGENT Finishes	Description
03	Bright brass, clear coated
04	Satin brass, clear coated
09	Bright bronze, clear coated
10	Satin bronze, clear coated
10B	Dark oxidized satin bronze, oil rubbed
10BE	Dark oxidized satin bronze equivalent
10BL	Dark oxidized satin bronze, clear coated
14	Bright Nickel, clear coated
15	Satin Nickel, clear coated
20D	Statuary bronze dark powder coated
26	Bright chromium plated
26D	Satin chromium plated

Standard and Coastal Series Levers

A Lever Design

- Lever: A-Solid forged or cast
- Must specify hand when ordering



B Lever Design

- Lever: B-Solid forged or cast



E Lever Design

- Lever: E-Solid forged or cast



F Lever Design

- Lever: F-Solid forged or cast

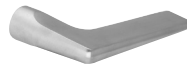

J Lever Design

- Lever: J-Solid bar stock



L Lever Design

- Lever: L-Solid forged or cast



P Lever Design

- Lever: P-Solid forged or cast



W Lever Design

- Lever: W-Solid bar stock



Coastal Series™ Levers

- Solid cast brass

G - Gulfport™

- Must specify hand when ordering



R - Rockport™



S - Sanibel™

- Must specify hand when ordering



Y - Yarmouth™

- Must specify hand when ordering















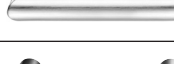
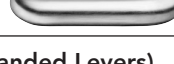













Studio Collection Levers

Multi-Point Auto Deadlocking Shutter System

SARGENT
ASSA ABLOY

Copyright © 2007-2023, SARGENT Manufacturing Company. All rights reserved. Reproduction in whole or in part without the express written permission of SARGENT Manufacturing Company is prohibited. Patent pending and/or patent www.assaabloyds.com/patents.

Aventura Series		
Lever	Design	Handed
MB		-
ME		-
MF		-
MG		-
MI		-
MW ¹		-
NF		-
Odeon Series (Handed Levers)		
MN ²		Yes
MH ²		Yes
MK ²		Yes
MS ²		Yes
MU ²		Yes
MV ²		Yes
NS ^{1,2}		Yes
NU ^{1,2}		Yes
MX ^{1,2}		Yes

Notting Hill Series		
Lever	Design	Handed
MA ²		No
MQ ²		Yes
MT ²		Yes
MM ²		Yes
MY ^{1,2}		Yes
MO ²		No
MZ ^{1,2}		Yes
Centro Series		
MC ²		-
MD		-
MJ		-
MP ²		-
ND ¹		-
NJ ¹		-













Features









- Levers with curves and contours provide a comfortable grip
- All levers meet ADA compliance for national codes
- All levers – solid brass (for stainless steel consult factory)

1. Lever returns within 1/2" (13mm) of door face
2. Not available in 32D or 32 finish

Studio Collection Levers

Multi-Point Auto Deadlocking Shutter System

Gramercy Series ³		
Lever	Design	Handed
RCM		-
RAL		-
REM		-
RAM		-
RAS		-
RAG		-
RGM		-
Wooster Square		
H001		-
H002 ¹		-
H003		-
H004		-
H005 ¹		-
H006 ¹		-

Grant Park		
Lever	Design	Handed
H007		-
H008		Yes
H009		-
H010		-
H011		-
Berlin		
H015		-
H016 ¹		-
H017		-
H018		-

¹ Lever returns within 1/2" (13mm) of door face.

² Levers are not available with Simpli™ Roseless trim.

³ Gramercy levers are customized. See page 10 for ordering information.

Studio Collection Levers: Finishes

Multi-Point Auto Deadlocking Shutter System

SARGENT
ASSA ABLOY

Gramercy Finish Codes

ANSI/BHMA Finish	SARGENT Finish	Gramercy Code*	Description
630	32D	30	Satin Stainless Steel
629	32	29	Bright Stainless Steel
613E	10BE	3E	Dark Oxidized Satin Bronze, Equivalent
N/A	BSP	BS	Black Suede Powder Coat
N/A	WSP	WS	White Suede Powder Coat
N/A	N/A	BK	Black (Santoprene™ or leather insert)
N/A	N/A	BN	Brown (leather insert)

*Code used to specify Gramercy Series finishes only. Use available finishes list to specify desired finish when ordering.

Gramercy Lever Descriptions & Available Finishes

Lever Designation	Lever Description	Available Finishes (AS ORDERED)
RAG	Grooved Insert	3030, 2929, 2930, 3029, 3E3E, BSBS or WSWS
RAL	Leather Insert	30BK30, 30BN30, 29BK30, 29BN30, 3EBK3E, BSBKBS, WSBKWS, 3EBN3E, BSBNBS or WSNBWS
RAM	Satin Metal Insert	2930 only (SEE NOTATION)
RAS	Santoprene Insert	30BK30, 29BK29, 3EBK3E, BSBKBS or WSBKWS
RCM	Raised Band	2930, 2929, 3030, 3029, 3E3E, BSBS or WSWS
REM	Plain	2930, 2929, 3030, 3029, 3E3E, BSBS or WSWS
RGM	Two Grooves	2929, 3030, 3E3E, BSBS or WSWS

Notes for Two-tone finishes:

- 2930 Finish: grip of lever is 32D, balance of lever is 32. Rose/escutcheon and lock finish will be 32
- 3029 Finish: grip of lever is 32, balance of lever is 32D. Rose/escutcheon and lock finish will be 32D

Mechanical & Cylinder Options

Multi-Point Auto Deadlocking Shutter System

Mechanical Options:

Features	Option	Description
Security Fasteners	36-	Six lobe security head screws
Tactile Warning Options	75-	Tactile Warning -Milled Inside Lever (Not available with Studio & Coastal Series Levers and the A Lever)
	76-	Tactile Warning -Milled Outside Lever (Not available with Studio & Coastal Series Levers and the A Lever)
	77-	Tactile Warning -Milled Inside & Outside Lever (Not available with Studio & Coastal Series Levers and the A Lever)
	85-	Tactile Warning -Abrasive Coating on Inside Lever
	86-	Tactile Warning -Abrasive Coating on Outside Lever
Finish Protection	87-	Tactile Warning -Abrasive Coating on Outside Lever & Inside Lever
	CPC-	Clear Powder Coat (Available for 26 & 26D Finishes)
	SG-	MicroShield® antimicrobial clear powder coat (only available with 15 and 26D finishes)

Cylinder Options:

Cylinder Type	Option	Description
Conventional Cylinder	Std	SARGENT Conventional Cylinders
Degree Key System	DG1-	SARGENT Degree Key System Level 1 (Bump and pick resistant)
	DG1-21-	Degree Level 1 Construction Master Keying
	DG1-60-	Degree Level 1 Removable Disposable Construction Core
	DG1-63-	Degree Level 1 Removable Core
	DG1-64-	Degree Level 1 Removable Construction Keyed LFIC
	DG1-65-	Degree Level 1 Unassembled/Uncombined Core
	DG1-78-	Degree Level 1 Exposed Plug (For use with LE3/LE4 escutcheons only)
	DG2-	SARGENT Degree Key System Level 2 (Geographically exclusive; bump and pick resistant)
	DG2-21-	Degree Level 2 Construction Master Keying
	DG2-60-	Degree Level 2 Removable Disposable Construction Core
	DG2-63-	Degree Level 2 Removable Core
	DG2-64-	Degree Level 2 Removable Construction Keyed LFIC
	DG2-65-	Degree Level 2 Unassembled/Uncombined Core
	DG2-78-	Degree Level 2 Exposed Plug (For use with LE3/LE4 escutcheons only)
	DG3-	SARGENT Degree Key System Level 3 (Geographically exclusive; UL437 certified; bump and pick resistant)
	DG3-21-	Degree Level 3 Construction Master Keying
	DG3-60-	Degree Level 3 Removable Disposable Construction Core
DG3-63-	Degree Level 3 Removable Core	
DG3-64-	Degree Level 3 Removable Construction Keyed LFIC	
DG3-78-	Degree Level 3 Exposed Plug (For use with LE3/LE4 escutcheons only)	
Signature Key System	10-	SARGENT Signature Key System (Not Available with other Key Systems)
	10-21-	SARGENT Signature Construction Key System (Lost Ball)
Signature: Large Format Interchangeable Core (Removable Core)	10-63-	SARGENT Signature LFIC (Removable Core) Cylinder
XC- Key System	11-	XC Key System (Not Available with other Key Systems, Unless specified)
	11-21-	XC- Construction Key System (Lost Ball)

Cylinder Options

Multi-Point Auto Deadlocking Shutter System

Cylinder Options:

Cylinder Type	Option	Description
XC- Large Format Interchangeable Core + (Removable Core)	11-60-	Hardware to accept XC- Permanent LFIC (Removable Core), Disposable plastic Core- provided
	11-63-	Hardware provided with XC- LFIC (Removable Core) Cylinder - (Includes masterkeying, grand masterkeying)
	11-64-	Hardware provided with Keyed construction core to accept XCLFIC (Removable) Permanent Core (ordered Separately)
XC- Small Format Interchangeable Cores +	11-70-7P-	Hardware to accept XC- SFIC (7 Pin) XC- Permanent Cores, plastic disposable core provided
	11-72-7P-	Hardware to accept XC- SFIC (7-pin Keyed Construction Core provided) cylinder Permanent core ordered separately
	11-73-7P-	Hardware supplied with XC- Small Format 7-Pin interchangeable core (Includes masterkeying, grand masterkeying)
	11-65-73-7P	Hardware provided to accept XC- Uncombined 7-Pin SFIC (Permanent) Core - (Packed Loose)
Construction Key Systems	21-	SARGENT Lost Ball Construction Keying for Conventional, XC and Signature Series (N/A with 63-, 73-, 82-, SC- & SE-)
	22-	SARGENT Construction Split Key System for Conventional Cylinders (Existing Systems) (N/A with 10-, 11-, 63-, 73-, 82-, SC- & SE-)
Old Style Removable Core	51-	Removable Core Cylinder (Old Style) provided (Existing systems only)
	52-	Removable Construction Core (Old Style) Permanent core ordered separately (existing systems only)
Large Format Interchangeable Core (Removable Core)	60-	Hardware to accept SARGENT Permanent LFIC (Removable Core), Disposable Plastic Core provided (Permanent Cores ordered separately)
	63-	Hardware provided with LFIC (Removable Core) Cylinder - (Includes masterkeying, grand masterkeying)
	64-	Hardware provided with Keyed construction core to accept LFIC (Removable) (Permanent Core ordered separately)
Small Format Interchangeable Cores	70-	Hardware to accept 6- or 7-Pin SFIC Permanent Cores, plastic disposable core provided
	72-	Hardware to accept 6- or 7-Pin SFIC (Keyed Construction Core provided) Cylinder (Permanent Core ordered separately)
	73-	Hardware supplied with 6-Pin SFIC (Includes masterkeying, grand masterkeying)
	65-73-	Hardware provided to accept Uncombined 6-Pin SFIC (Permanent) Core - (Packed loose for field keying)
	65-73-7P-	Hardware provided to accept Uncombined 7-Pin SFIC (Permanent) Core - (Packed loose for field keying)
	73-7P-	Hardware supplied with Small Format 7-Pin Interchangeable Core (Includes masterkeying, grand masterkeying)
Keso F1- & Keso	81-	Hardware provided with housings to accept Keso (83) & Keso F1 (F1-83-) removable cores. (Permanent Cores ordered separately)
	82-	Hardware provided with SARGENT Keso Security Cylinder
	F1-82-	Hardware provided with SARGENT Keso F1 Security Cylinder (Patented)
	83-	Hardware supplied with SARGENT Keso Security Removable Core cylinder
	F1-83-	Hardware supplied with SARGENT Keso F1 Security Removable Core cylinder (Patented)
84-	Hardware provided with SARGENT Keso Construction Cores (Permanent Cores ordered separately)	
Bump Resistant	BR-	Bump Resistant Cylinder (Available with Conventional & Conventional XC Cylinders Only)
Less Cylinder	LC-	Less Cylinder
Schlage Keyways	SC-	Schlage C keyway cylinder, 0 bitted
	SE-	Schlage E keyway cylinder, 0 bitted

Note: For V-10 Cylinders and information contact ASSA

Note: When tying into existing key systems contact Key Records for compatibility

FM6100: How to Order & Architectural Specification

Multi-Point Auto Deadlocking Shutter System

How to Order: FM6100 Multi-Point Auto Deadlocking Storm Shutters

10-	FM61	13	EC	MJ	RH	26D	**54"
Options	Series	*Function Designation	Escutcheon	Lever	Hand	Finish	Opening Height
Page 9 & 10	FM61	13 15 01	EC Control Standard	Page 7 & 8	RH LH	Page 7	

Note: For 1-3/4" thick doors only

* Function designation is determined by function of outside trim

** Shutter deadlocking systems are available in two height ranges 3'0" - 4'6" and 4'7" - 6'8"; SARGENT will supply the correct range based on opening height specified

Hand

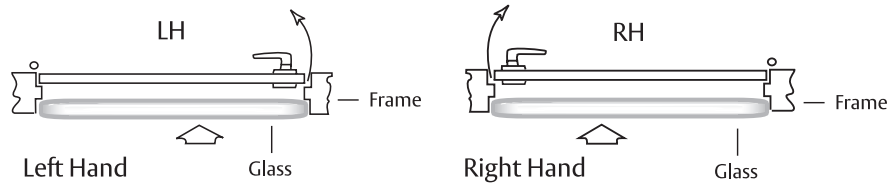

FM6100 Series Storm Shutter Multi-Point Latching System

Three-Point Locking System Devices: Three-Point, auto deadbolt locking devices are engineered for use on inswing and outswing shutter applications at windstorm safe shelter room locations. Concealed, fortified steel construction secures the shutter to the frame at top, bottom and center latching positions. All three latching points shall be automatically activated when the device is closed and retracted with one single lever activation motion.

- The Multi-Point latching system device is part of an integrated shutter, frame and hardware assembly UL Classified to FEMA P320 (2014), FEMA P361 (2015) and ICC 500 (2014) for inswing and outswing applications.
- Latchbolt Construction:
 - Mortised Center bolt: Single piece, 13 gage chrome plated steel lock case with 3/16" thick stainless steel front. Stainless steel, 1" throw deadbolt. 2-3/4" backset standard with 1/4" stainless steel center bolt strike.
 - Top Latch: Through-hardened steel latchbolt with 7/8" projection, 1/8" steel latchbolt front, and 5/8" stainless steel latch housing secured with 5/16-18 Holo-Krome® fasteners.
 - Bottom Bolt: 3/4" diameter steel nylon coated bolt with 3/4" projection and 1/8" steel reinforcement plate. Brass strike housing secured with 1/4-20 Holo-Krome fasteners.
- Provide devices with heavy-duty escutcheon trim and solid cast levers matching the design style and architectural finishes as the balance of the lockset and latches specified.
- Storm shutters are furnished as a complete door, frame, and hardware assembly for openings measuring from 2'8" x 3'0" minimum to 4'0" x 6'8" maximum.
- Three-Point locking system devices shall have a seven-year limited warranty.

The ASSA ABLOY Group is the global leader in access solutions. Every day, we help billions of people experience a more open world.

ASSA ABLOY Opening Solutions leads the development within door openings and products for access solutions in homes, businesses and institutions. Our offering includes doors, frames, door and window hardware, mechanical and smart locks, access control and service.

SARGENT[®]
ASSA ABLOY

SARGENT Manufacturing Company
100 Sargent Drive
New Haven, CT 06511 USA
800-727-5477
www.sargentlock.com

Founded in the early 1800s, SARGENT[®] is a market leader in locksets, cylinders, door closers, exit devices, electro-mechanical products and access control systems for new construction, renovation, and replacement applications. The company's customer base includes commercial construction, institutional, and industrial markets.

Copyright © 2007-2023, SARGENT Manufacturing Company. All rights reserved. Reproduction in whole or in part without the express written permission of SARGENT Manufacturing Company is prohibited. Patent pending and/or patent www.assaabloydss.com/patents.