

Signature[®] Series



Table of Contents	Page
Signature® Features and Key Management Software	3
Simple K Software Order Form	4
Signature Components	5
Mortise & Rim Cylinders.....	6
Bored Locks Cylinders.....	7
10-6300 LFIC Cylinders and 6300 Series Tools.....	8
Key Blanks/Cut Master Keys	9
Visual Key Control	10
Keyway Control	11
Construction Master Keying (21- Option)	12
Registration Forms	13
How to Order/Special Features.	14

Policy

The SARGENT® Signature® protected cylinders and keys are available through the normal channels of distribution.

Assignment of unique SARGENT Signature patterns must be pre-approved by the factory.

A letter requesting a SARGENT Code Pattern Registration Form must be sent to the Key Records Department in New Haven, CT.

Signature patterns will be issued by predefined geographical boundaries and assigned in accordance with a standard factory policy. This policy would not reuse the same key way with the same Signature dimple pattern in the same state or adjacent states providing a large area of exclusivity. For example a system in Connecticut would not be reused in New York, Massachusetts or Rhode Island.

A letter of authorization under the letterhead of the End-User must accompany any purchase orders for any products which involve SARGENT's Signature cylinders and/or keys.

SARGENT Signature patterns are assigned at the End-User level.

SARGENT Cylinder & Key Control Products

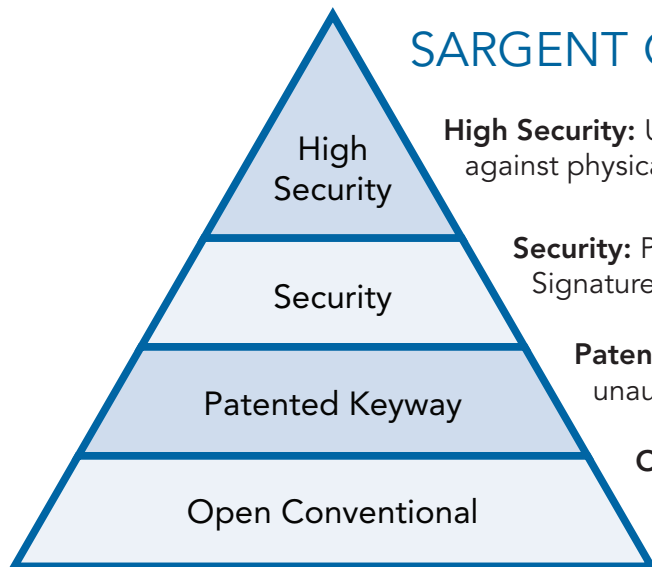

High Security: UL437 Drill & Pick-Resistant Systems offer protection against physical attacks. Includes Degree DG3 and UL-Keso.

Security: Protection against picking. Includes Degree DG2, Signature and Keso.

Patented Keyway: Keys are protected against unauthorized duplication. Includes Degree DG1 and XC.

Open Conventional: Legacy systems whose patents have run out and are not protected.

Copyright © 2007-2024, Sargent Manufacturing Company, an ASSA ABLOY Group company. All rights reserved.
Reproduction in whole or in part without the express written permission of Sargent Manufacturing Company is prohibited.

* See product catalogs for more information

SimpleK Master Key System and Key Management Software

Signature® Series

SARGENT
ASSA ABLOY

SimpleK

SimpleK is a flexible and intuitive software program that streamlines and simplifies the complexities of managing master key systems, keys, and facilities. It combines all tools needed by locksmiths, facility managers, security officers, and anyone else involved in the key management processes.

The software provides total key control with audit trails, outstanding keys, overdue keys, tools for the rekeying process, and more. SimpleK software allows you to import maps and floor plans to see who has access to each individual door, the associated keys, and hardware on the opening.

SimpleK allows you to manage keys and keying systems of all sizes and types. This includes: Medeco, Corbin Russwin, ASSA ABLOY ACCENTRA™, SARGENT, ASSA, ABLOY, Schlage®, Best®, and many others.

Features:

- Advanced tools for locksmithing and key control
- Manage all key systems (unlimited number of records)
- Robust import tools to bring current data into SimpleK
- Interactive floor plans
- Master key system design and expansion
- Key requests, approvals, issuances, and returns workflow
- Cylinders and core pinning (verifies key interchange)
- Door-Key association visualization and rekeying solution
- Easily identify keys, access, and hardware on openings
- Visibility to audit trails and outstanding/overdue keys

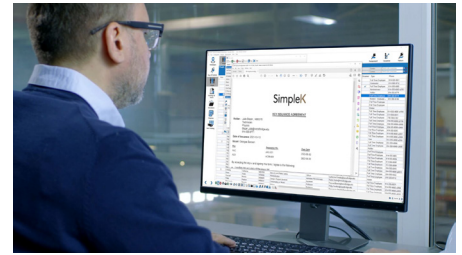

SimpleK – Standard Edition	
Description	Part Number
Primary License (3 users)	SMK040-30
Updates & Support Plan on Primary License, 1 year	SMK040-31

SimpleK – Professional Edition	
Description	Part Number
Primary License (3 users)	SMK042-30
Additional license	SMK042-32
Updates & Support Plan on Primary License, 1 year	SMK042-35
Updates & Support Plan on Additional License, 1 year (per Add. Lic.)	SMK042-33

Add-On Modules	
Description	Part Number
Item Tracking	SMK032-31
Web Interface	SMK032-33
Room Management	SMK032-35
Mobile Applications	SMK032-37

For more information, customer service or technical support, please call SimpleK at 800-315-0454 or visit www.simplek.com.

SimpleK Software Order Form

Signature® Series

SARGENT

ASSA ABLOY

Form is required for all SimpleK Software orders.

Brand*	
Distributor Purchase Order Number*	
Distributor Account Number*	
Part Number*:	<p>Standard Edition</p> <p><input type="checkbox"/> SMK040-30 Primary License (3 users)</p> <p><input type="checkbox"/> SMK040-31 Updates & Support Plan on Primary License, 1 year</p> <p>Professional Edition</p> <p><input type="checkbox"/> SMK042-30 Primary License (3 users)</p> <p><input type="checkbox"/> SMK042-32 Additional license</p> <p><input type="checkbox"/> SMK042-35 Updates & Support Plan on Primary License, 1 year</p> <p><input type="checkbox"/> SMK042-33 Updates & Support Plan on Additional License, 1 year (per Add. Lic.)</p> <p>Add-On Modules</p> <p><input type="checkbox"/> SMK032-31 Item Tracking</p> <p><input type="checkbox"/> SMK032-33 Web Interface</p> <p><input type="checkbox"/> SMK032-35 Room Management</p> <p><input type="checkbox"/> SMK032-37 Mobile Applications</p>

To receive your SimpleK license and download link with instructions for your new software package, the following End User Information is required:

Company/Institution Name*	
Mailing Address*	
City*	
State/Province*	
Zip/Postal Code*	
Country*	
Primary Point of Contact*	
Telephone*	
Email Address where license and download link will be sent*	

*Required field

Copyright © 2007-2024, Sargent Manufacturing Company, an ASSA ABLOY Group company. All rights reserved. Reproduction in whole or in part without the express written permission of Sargent Manufacturing Company is prohibited.

90105 05/24

Signature Components

Signature® Series

Extra security, exclusive end-user pattern, and protected key control are the main benefits of the Signature Series. The protected key design provides additional control over unauthorized key duplication, while the cylinder's unique design resists attempts at manipulation. The Signature feature is offered in the majority of Sargent keyways to provide a perfect solution to upgrading the level of control in an existing masterkey system.

The Signature key system is ideal for existing facilities that would like to upgrade to a protected key system with minimal effort.

The Signature key system consists of a 6 pin cylinder with 2 added blocking bars with shear lines (item 4) which work in conjunction with 6 factory loaded side pins. The side pin depths and locations vary and only work with a corresponding dimpled key. Non Signature keys are prevented from being inserted into the Signature cylinder. Signature keys can operate non-Signature cylinders.

Signature can easily be blended into most existing key systems while allowing the end user one master key that will open both Signature and non-Signature cylinders.

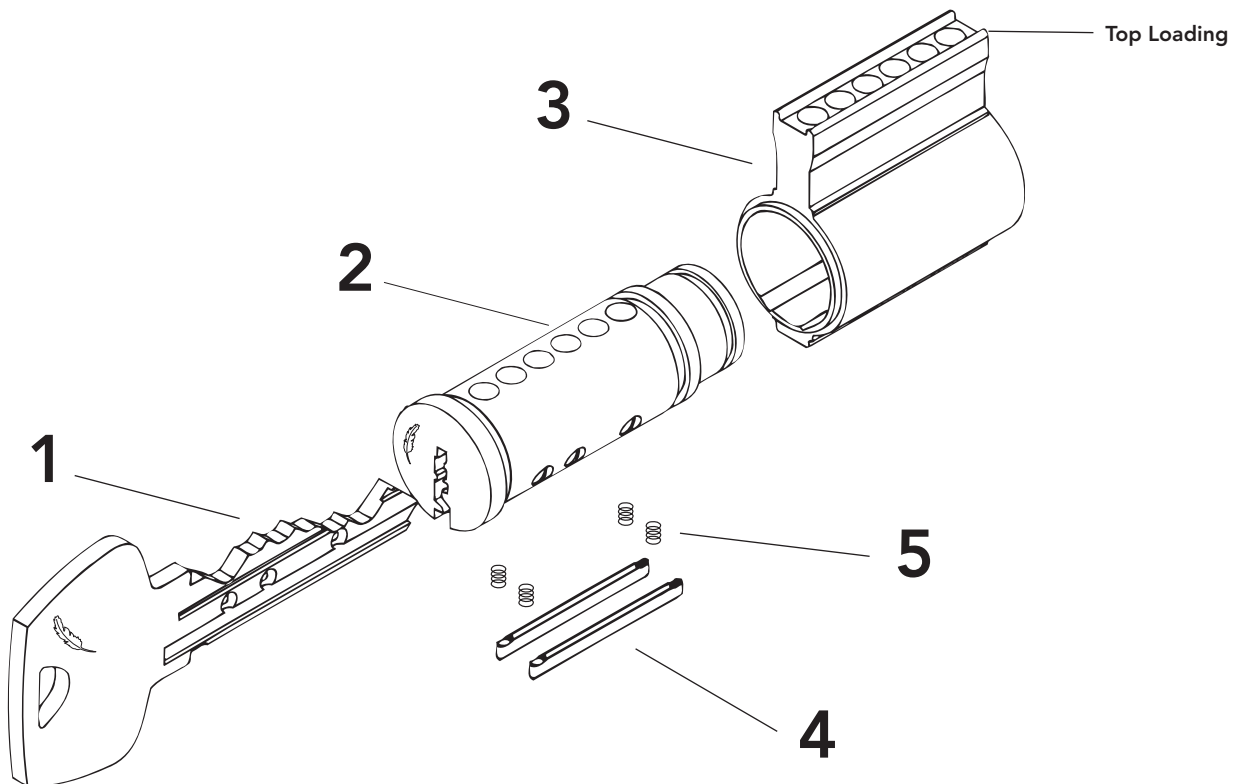

Key Blank

- 1** Standard key bitting can be accomplished in the field with any industry standard duplicating or code cutting machine.

Signature Barrel (Plug)

- 2** Unique Signature pattern code pins factory loaded. Field servicing not required.

Signature Body

- 3** Grooved to function with offset blocking bar assemblies.

Signature Offset Blocking Bar

- 4** (2) Two per cylinder. Locks out all but correctly dimpled and bitted keys.

Signature Offset Blocking Bar Springs

- 5** (4) Four per cylinder. Two per offset blocking bar. Supplies required spring force to prevent compromise of offset blocking bars by anything other than a correctly dimpled and bitted key.

Mortise & Rim Cylinders

Signature® Series

SARGENT
ASSA ABLOY

Mortise/Rim Cylinders

	Complete 6 Pin Assembly*	Barrel**	Body & Slide Assembly	Cylinder Length
40 Series Cylinder	10-41	13-3835	13-3726	1-1/8"
	10-42	13-3836	13-3727	1-1/4"
	10-43	13-3837	13-3728	1-3/8"
	10-44	13-3838	13-3729	1-1/2"
	10-46	13-3839	13-3730	1-3/4"
	10-48	13-3840	13-3731	2"
	10-50	13-3841	13-3732	2-1/4"
	10-52	13-3842	13-3733	2-1/2"
	10-54	13-3843	13-3734	2-3/4"
Rim Cylinder	10-34	13-3845	13-3847	

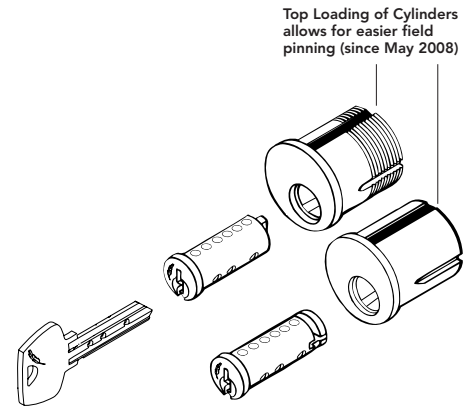

- Cylinder: Solid brass, 1-5/32" (29mm) diameter
- Cap: Brass, bronze or stainless steel
- Available for all functions, except 50 function
- Optional Collars/Spacers available and ordered separately, refer to product catalogs for additional information
- Mortise cylinder assemblies that are ordered without hardware are supplied with standard SARGENT offset cam 13-0664
- Cylinder finishes: 3, 4, 9, 10, 10B, 10BE, 10BL, 14, 15, 20D, 32, 32D, BSP, WSP
- Plug finishes: 4, 15, BSP

* Cylinders offered in the following finishes: US 3, 4, 9, 10, 10B, 10BE, 10BL, 20D, 32, 32D, BSP, WSP

** Barrels offered in US 4, 15, and BSP only

Optional Cams for 10-40 Series Mortise Cylinders*



Standard Cam
(13-0664)

Standard Cam
10-41 thru 10-56



#105
(13-0665)

Short cam for 8292
and 8216 functions
inside only



#101
(13-0512)

Adams Rite
1850, 4700



#113
(13-0921)

SARGENT 4370 Series
key switches



#106
(13-0938)

"Open" Schlage "L"

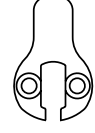

#112
(13-0097)

"Open" Misc.

10-34 Rim Type Cylinders

- Complete assembly (6 pin), specify 10-34
- Plug assembly, specify 13-3845
- Shell & slide assembly, specify 13-3847
- 27/32" (21mm) screw pattern for through-bolted SARGENT exit devices
- Cylinder: Solid brass
- Cap: Brass, bronze or stainless steel
- Furnished standard with "break-off" screws and back plate
- Optional collars/spacers available and ordered separately, refer to product catalogs for additional information
- Horizontal tail piece only
- Cylinder finishes: 3, 4, 9, 10, 10B, 10BE, 10BL, 15, 20D, 32, 32D, BSP, WSP
- Plug finishes: 4, 15, BSP

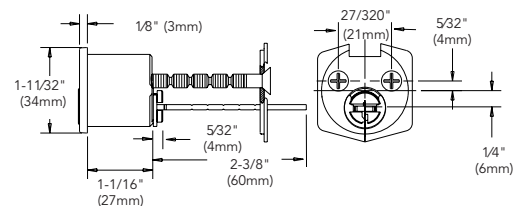

Copyright © 2007-2024, Sargent Manufacturing Company, an ASSA ABLOY Group company. All rights reserved. Reproduction in whole or in part without the express written permission of Sargent Manufacturing Company is prohibited.

90105 05/24

Bored Locks Cylinders

Signature® Series

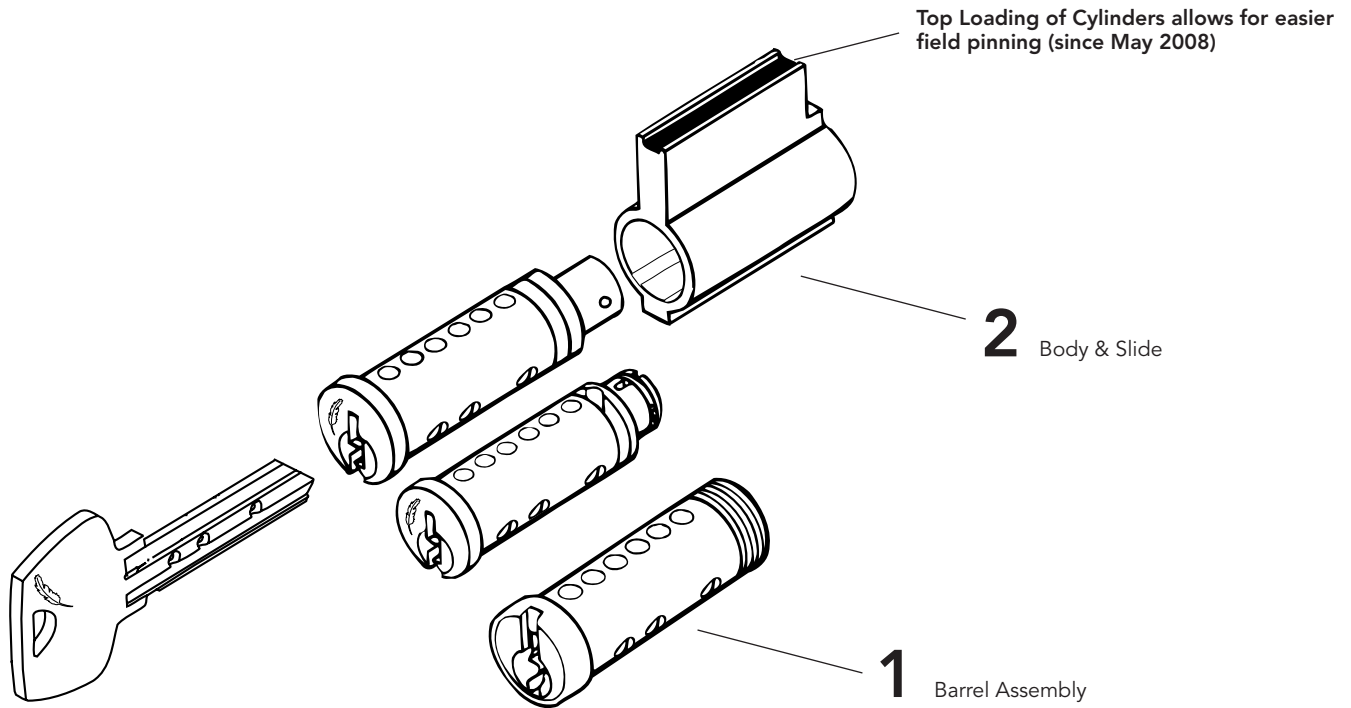

Bored Locks

Functions	Lockset	Assembly	Barrel Assembly #1	Body & Slide #2
All except 50 function	11 Line	10-C11-1	13-3851	13-3710
All except 50 function	10X Line	10-C10X-1	13-3851	13-3710
All except 50 function	10, 8L, 7 Lever, 6500	10-C10-1	13-3851	13-3710
All except 50 function	9, 8*	10-C8-1	13-3850	13-3852
All except 50 function	6 "S", "N"	10-C6-1	13-3851	13-3710
All except 50 function	6 "B"	10-C6-1B	13-3851	13-3710
All except 50 function	8X	10-C8X-1	13-3938	13-3937

Auxiliary Locks (Deadbolts)

Lockset	Assembly	Barrel #1	Body #2
474, 484	10-C480-1	13-3849	13-3855
475, 485, 487	10-C480-2	13-3849	13-3855
486	10-C480-3	13-3849	13-3855
464*	10-C460-1	13-3849	13-3854
465*	10-C460-2	13-3849	13-3854

Note: Parts on this page reflect only those that are unique to the Signature feature. For all other cylinder components, refer to the standard cylinder section

Cylinders offered in 04, 15, & BSP only

For products not listed, contact factory for availability

* Discontinued Product Line

10-6300 LFIC Cylinders and 6300 Series Tools

Signature® Series

SARGENT
ASSA ABLOY

Signature LFIC core cylinders offer a protected cylinder with the convenience of quickly changing cores without lock disassembly. Consult individual product catalogs for availability.

Ordering examples:

10 Line Cylindrical – 10-63-10G05 LL x 32D x LH key set
8200 Mortise – 10-63-8204 LNL x 32D x RH key set

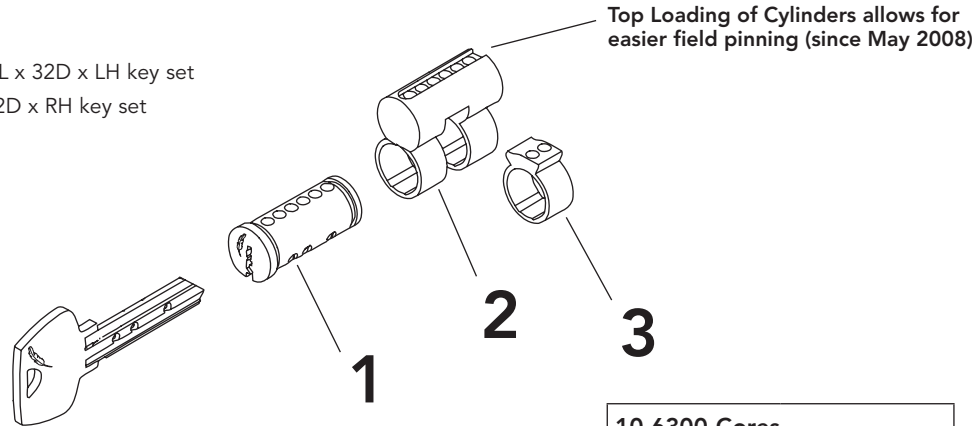

10-6300 LFIC can be used with:

- 10-63-34 Rim Cylinders
- 10-63-40 Series Mortise Cylinders (in Sizes 42 (1-1/4"), 43 (1-3/8"), 44 (1-1/2") & 46 (1-3/4"))
- 10-63-11 Line (T-Zone Locks)
- 10-63-10 Line Locks
- 10-63-7 Line Locks
- 10-63-6500 Series
- 10-63-8 & 10-63-9 Line Bored Locks
- 10-63-758 Padlocks
- 10-63-858 Padlocks

Note: Not available with the UL option

10-6300 Cores	
Complete Core	10-6300 x finish
#1 Barrel	13-0976
#2 Body Only	13-0977
#3 Sleeve	13-1074
Slide (Not Shown)	13-0797/ 13-1341*

* Slides for cylinders mfg after 3/06

- 6300 Cams are factory installed and are not removable
- 6300 Cams are not sold separately
- Specify required Cam as a suffix: 63-44-105 cam
- For Standard Cam: No Suffix is required

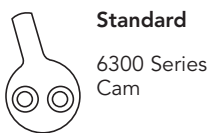

Standard

6300 Series Cam



#105

Cam for 6300 Series 16 & 92 mortise function locks



#101

ADAMS RITE 1850 4710



#106

Schlage "L"



#113

4370 Series key switch



#112

Wide Straight

436-1 Slide Block Kit

- Includes fixture and staking tool for use only with the (10)- 6300 Series Cylinders manufactured after March 2006 for the ease of top loading in the field
- The kit includes 100 each slides (p/n 13-1341), Staking Block and staking tool
- Cylinders manufactured after March 2006 will not include the box around the SARGENT logo and can be used with this kit

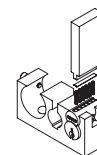

Cores without a box around the word "SARGENT"

432 RC Tool for 6300 LFIC (Removable Core)



- The 432 RC tool to assist in installing SARGENT LFIC (Removable Core) Mortise Housings. This tool makes it easy to thread a cylinder body into a Mortise lock and can also be used to check the cylinder function of a lock before installing the cylinder core
- Order as: 432 RC for the 6300 LFIC (Removable) Core Installation Tool

Note: Cores made prior to March 2006 can be bottom loaded or top loaded with slide 13-0797, which must be staked.

Key Blanks/Cut Master Keys

Signature® Series

Part Numbers

All Signature key blanks are stamped at the factory with the Quill Logo and the individual Signature pattern. The Signature key blanks with the end user's unique dimple pattern are available only from SARGENT.

Available Keyways: L and R. For other sections, call factory.

Orders for these key blanks must be accompanied by a letter of authorization under the end user's letterhead. This letter must contain the required key section(s) and appropriate authorizer's identification

The Signature Key Blank for field cutting and stamping key is offered in two styles.

Version one: The key blank has the standard SARGENT logo embossed on one side. The other side has the Signature Quill Logo, Do Not Duplicate, specific Signature code pattern, keyway and space for one additional line of stamping such as key set.

Version two: The key is less SARGENT logo. This allows for additional space for optional stamping such as custom field stamping. The other side has the Signature Quill Logo, Do Not Duplicate, specific Signature code pattern key way and one additional line for stamping such as key set. Key set symbols or alternate symbols will be stamped on all master keyed orders.

Two types of Signature featured key blanks are available for specific Keyway (sections) configurations: the day key or single key section, and the Master Keyway sections.

10-S6275 Day Key x keyway
10-S6270 Master Section x keyway

Note: Sold in boxes of 50 per keyway

For cut master and control keys order by the following #s:
Change (Day) key 10 S6272 CHK
Master or Grandmaster 10-S6272 MK
Control Key 10-S6272 CTL
Control Key 10-S6255 CTL used with 1 bitted 10-6300 cores

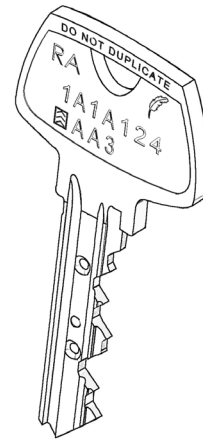

Key bittings can be cut on any industry standard key cutting machine.

437S Signature Keying Kit

Used to service SARGENT Signature cylinders. Includes all of the same components as the 437C. Includes the brass pins, springs and tools needed to rekey SARGENT conventional, XC cylinders (Except SFIC) and interchangeable cores master keyed after January 2009. This heavy duty steel kit prevents pins from mixing. The kit includes 100 each of top springs 13-0265, 100 each 13-1769 springs used with standard drivers in the (10-) 6300 cores and 100 each of bottom and master/driver pins used in the following multi-family keyways: LA, RA, HA, CA, AA, BA, GA, KA, NA and VA.

Note: When repining SARGENT 10-6300 large format interchangeable cores use hollow drivers in chambers 3 and 4 as found in the 437 RC keying kit.

Tools included with kit are:

- Tweezers, 13-0498
- Bitting Gauge #435
- Loading Thimble ("Plug Holder" LT2)
- Loading Rod for 6, 8, 10, 11, mortise & rim cylinders, 13-1034
- Loading Rod for 480, 470, 460 and 6300 Cores, 13-1035
- Loading Rod Blades 13-1138 and 13-1037
- See Table on Page 16 for pins included in Cylinders and Components catalog
- 100 Blocking Bar Springs, 13-0986
- 10 each Blocking Bars, 13-1109
- 1 each Field Service Tool, 13-3916

When pins are sold separately, they are packaged in easy to see and use foil & plastic packages in quantities of 100 per size.



437 RC Large Format Interchangeable (Removable) Core Keying Kit

Use with the 437C or 437S kit. Includes additional pins to repin SARGENT 6300 and 10-6300 Large Format Interchangeable (Removable) Core cylinders that have been pinned using the hollow drivers.

The kit includes special hollow top driver pins and springs which are used in the 3rd and 4th chambers of master keyed cores.

These pins are in the same increments as standard pins.

Each kit includes:

- 100 each hollow top pin springs, 13-0487
- 50 each cylinder retainers, 01-0660
- 50 each (hollow top pins)



Experience a safer and more open world

Visual Key Control (Stamping)

To allow for easier key and cylinder identification, SARGENT offers the option for permanent stamping of keys and/or cylinder with industry standard alpha-numeric keyset symbols.

Non-visual key control stamped change (day) keys include keysets as standard, (Item A) unless specified in keying order lead sheet submitted with order requesting to be omitted and substituted with bitting numbers.

Master level keys do not include bitting numbers. Master level keys include system register numbers stamped on the first line, and the standard visual key control designations on the second line (Item B).

Up to 7 characters available for permanent stamping for Visual Key Control

- Key and cylinder identified by industry standard alpha-numeric keyset symbols
- Concealed stamping on mortise and rim cylinders and bored lock cylinders available on the slide only (Item D or I)
- Cylinder-slide stamping available on 5100 and 6300 SARGENT LFIC (removable) cores, bored lock, mortise/rim cylinders (Item E, I D)
- Core side engraving available for 7300B Series up to 7 characters (Item F)
- Special key stampings available, such as "DO NOT DUPLICATE" or "CITY OF PHOENIX"
- XC and Signature cylinders not available with visual plug stamping
- XC and Signature cylinders available with only concealed slide stamping (Item D, E and I)
- Signature LFIC 10-6300 available with cylinder slide stamping (Item E)

Note: SARGENT will stamp alternate identity codes on cylinders and/or keys whenever requested. This alternate stamping can not be different if both are to be stamped. Master Level Keys can also be stamped with a single alternate code

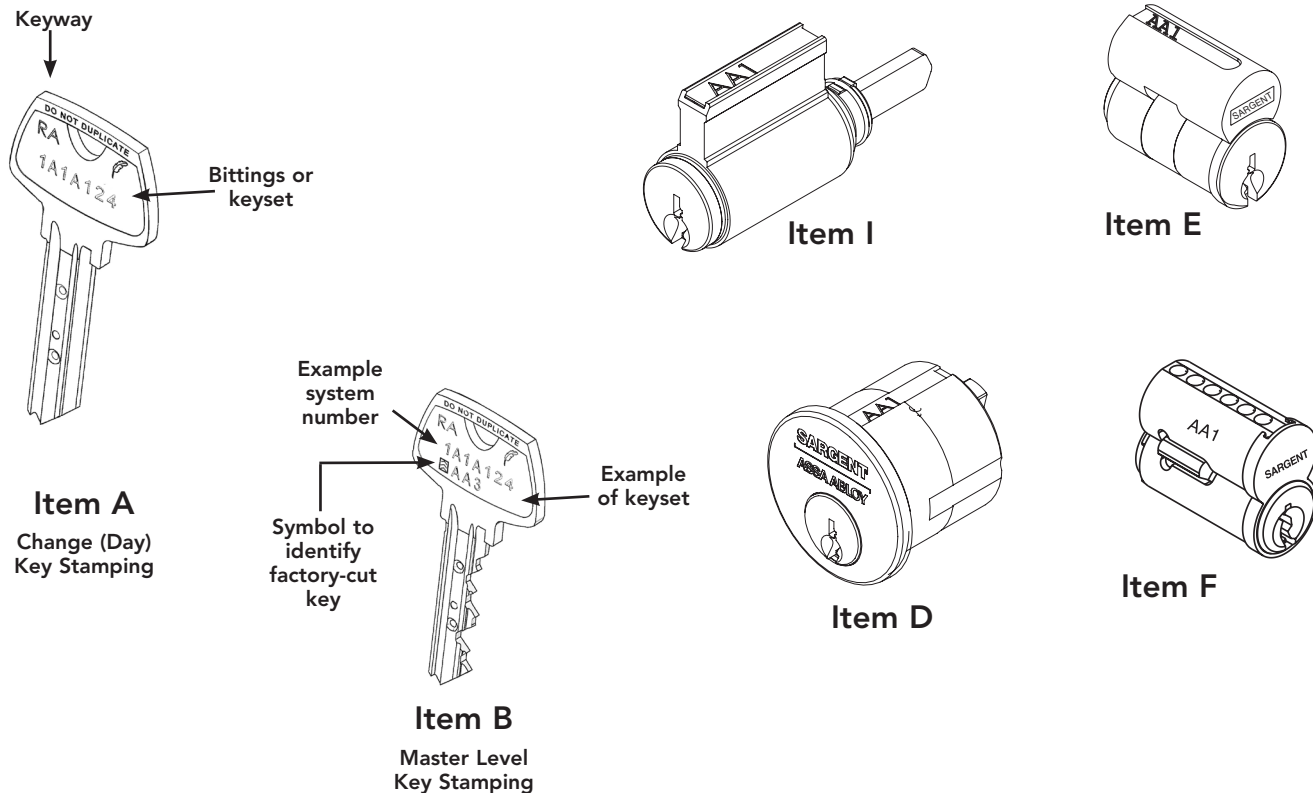

Tamper Proof Packaging

For the highest level of security for the end user, Tamper Proof Packaging is used on all Master Keys, Signature key blanks and all restricted key blanks. This heat sealed shrink wrap identified with "SARGENT Sealed For Your Security" provides assurance of the integrity of the factory generated key system.

Signature vs. Standard Keyway Control

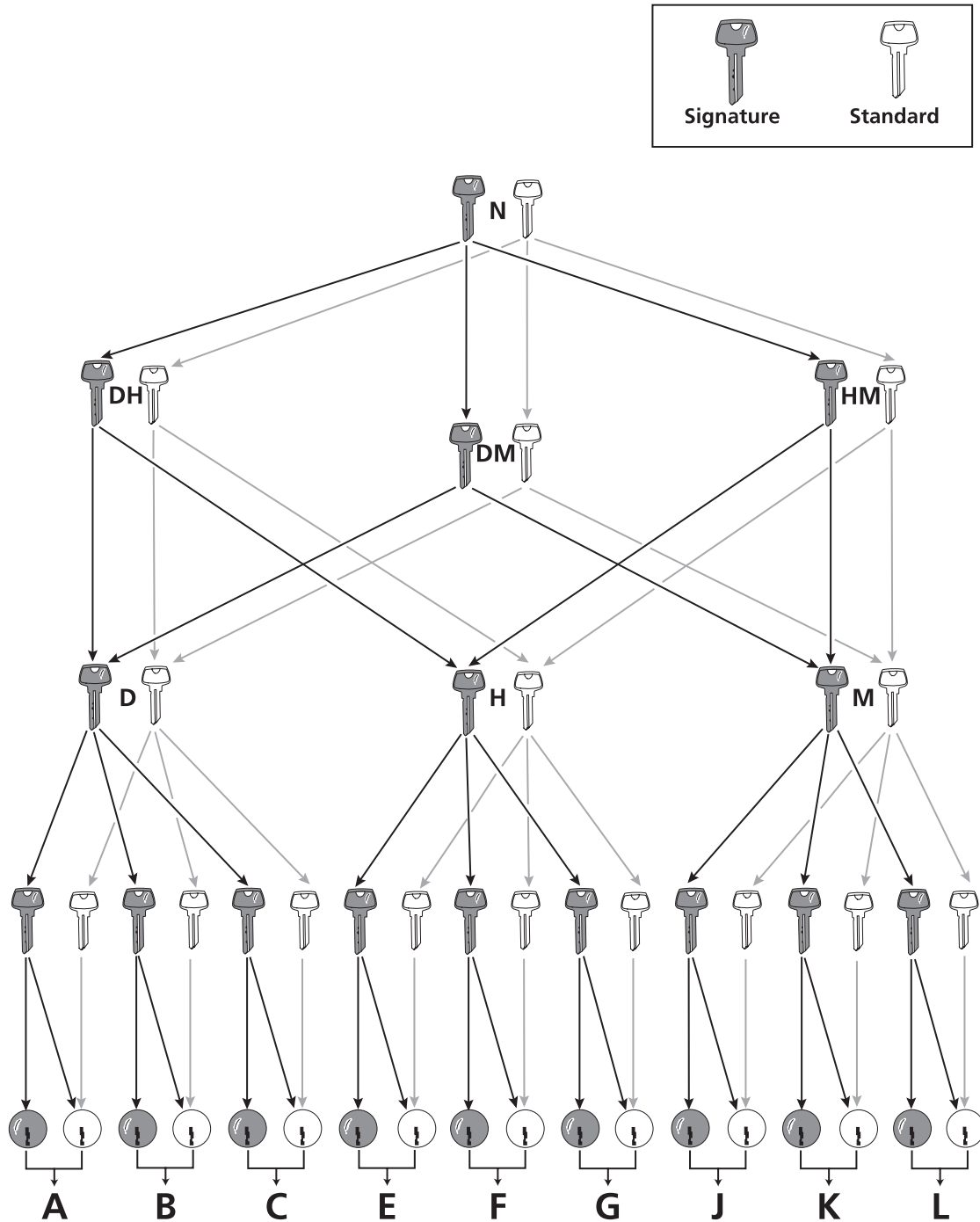

SARGENT Signature keys are produced with a special feature that allows them to operate Signature cylinders as well non-Signature cylinders within the same keyway family. The standard key does not contain the special feature which allows it to operate a Signature cylinder but will continue to operate non-Signature cylinders.

Signature key system can be easily blended into most existing facilities using the existing keyways (contact key records), but with the additional feature that allows operation only with Signature Keys. This prevents unauthorized access with a minimum effort. Typically all exterior cylinders and selected interior cylinders are upgraded to Signature to immediately stop unauthorized access, while still allowing one master to operate both types of cylinders.

Construction Master Keying (21-Option)

Signature® Series

SARGENT
ASSA ABLOY

With construction key in cylinder

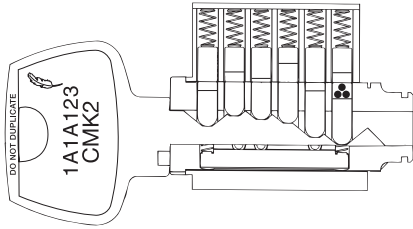

The SARGENT Signature Cylinder employs what is known in the industry as the “Lost Ball” method of Construction Master Keying. Use the 21- as the option when ordering this feature.

Note: Adding this feature to an existing SARGENT Master Key system may not be possible. Contact SARGENT key records department if this feature is required in an existing system

The SARGENT Signature Cylinder with “Lost Ball” method of Construction Master Keying is not offered with 10-63-. The 64- option is offered for construction keying when 10-6300 permanent cores are to be used.

With construction key in cylinder

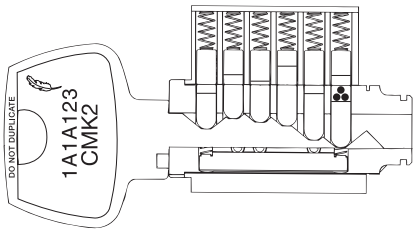

Construction key rotating cylinder plug

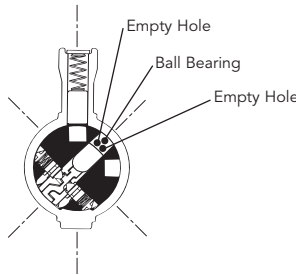

Example shows “Lost Ball” construction feature in last chamber of cylinder. Construction feature can be used in any chamber.

The ball bearings lie flat with one positioned behind the other. They are not stacked.

To void construction key using the day/change key

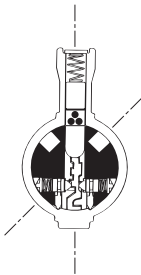

Change key inserted in cylinder.

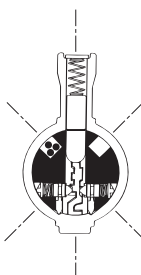

Change key rotated to position for extraction. Construction key now voided from cylinder.

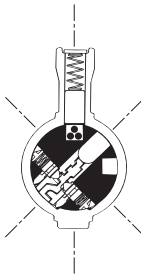

Change key rotating. Construction balls fall into hole in the side of plug.

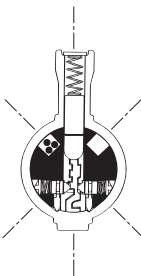

Construction key inserted after balls are trapped. Driver now extends into plug chamber. Construction key will not rotate.

Note: Ball bearings shown are for illustration purposes only. They do not stack, they align next to each other and lay flat.

Copyright © 2007-2024, Sargent Manufacturing Company, an ASSA ABLOY Group company. All rights reserved. Reproduction in whole or in part without the express written permission of Sargent Manufacturing Company is prohibited.

90105 05/24

Signature Code Pattern Registration Form

SARGENT Signature Series
Code Pattern Registration Form
100 Sargent Drive New Haven, CT 06511 Phone (203) 498-5540 Fax: (203) 776-5992

SECTION A Distributor Information (1) Date: ___/___/___

(2) Distributor Name: _____ (3) Acct# _____
 (4) City: _____ (5) State: ___ (6) Zip Code: _____
 (7) Contact Name: _____
 (8) Phone: () ___-___-____ (9) Fax: () ___-___-____

SECTION B Facility Information

(10) Facility Name: _____
 (11) Building Name: _____
 (12) Address: _____
 (13) City: _____ (14) State: ___ (15) Zip Code: _____
 (16) Area responsible for key system _____
 and Names of _____ Title: _____
 Authorizing _____ Title: _____
 Individuals _____
 Mailing Address _____ City, State, Zip _____
 Phone _____ Fax _____
(Please type or Print Clearly)

(17) Existing System? (Y/N) ___ (18) Existing TMK Code# _____ (19) Kwy: _____
 (20) System Spec.'s: System Const Removable Hotel Cylinder
 Level ___ Key ___ Core ___ Mky ___ Qty _____

SECTION C Area of Exclusivity Final Approval and assignment by Sargent

(21) National: ___ (22) Adjacent States: ___ (23) Other States: _____

SECTION D Authorization

FACTORY USE ONLY

Keyway Family: ___ Master Sections: ___ N ___ D ___ H ___ M ___ DH ___ HM ___ DM
 Single Sections: ___ A ___ B ___ C ___ E ___ F ___ G ___ J ___ K ___ L
 Signature Code: _____ PIN Code: _____ Type (R/A) _____
 Alternate Signature Code: _____



H756

The Signature Code Registration Form must be submitted prior to any purchase orders for products. This for is available from your authorized SARGENT distributor or SARGENT key records dept. @ 1-800-727-5477.

The information on this form is used by computer software to select the unique Signature code pattern for each key system and monitor the selection process to insure code patterns are not duplicated within the pre-defined area of exclusivity.

Cover Sheet for all Keyed Orders

SARGENT KEYING ORDER INFORMATION SHEETS

How to use this Interactive form: Put cursor over the red triangle. How to mark a box in the form

Customer/Account Number _____ Purchase Order Number _____	Ship To: _____ Note Special Shipping Addresses on Page 3
Sold to: _____	Phone: _____ Fax: _____
Contact: _____	Facility Name: _____
Facility Name: _____	Facility Contact: _____
Facility Contact: _____	Address: _____
Address: _____	City: _____
Key System Definition	Existing Key Systems
<small>Use this section for New Key Systems orders to be filled by the System. Use this section for Existing Key Systems orders to be filled by the System. Use this section for Existing Key Systems orders to be filled by the System.</small>	<small>(See information below)</small>
New Key Systems: Complete Scope of Key System Structure	Existing Register Number _____
GM Level1 _____	Existing TMK Billing and Keyway: _____
GM Level0 _____	Previous SARGENT order number _____
Master level2 _____	Are all special keys provided? Y / N _____
Are Submasters to be used? Yes No	<small>(if not providing, contact factory for compatibility requirements)</small>
<small>Attach separate sheet for information as needed</small>	Field Special Ed requires additional information below
<small>Note: Do not use this section to indicate quantities of physical cutkeys</small>	Authorization _____
Keying Notes attached _____	Signature Code: _____
<small>(Complex systems, unique conditions, etc.)</small>	Existing Pin Code: _____
	Letter of Authorization attached _____
	Initial Request Form Attached For New Sig Code _____
	V10 Code _____
	Letter of Authorization attached _____
	Contact Attached _____
	Keys _____ Authorization Forms attached _____

SARGENT KEYING ORDER INFORMATION SHEETS

Use this section for New Key Systems orders to be filled by the System. Use this section for Existing Key Systems orders to be filled by the System. Use this section for Existing Key Systems orders to be filled by the System.

Special Keying Requirements:	Hotel Keying Based In _____
Crosskeying _____	73. SARGENT Small Format Core _____
21/22. Composite Keying _____	73. Existing Best/Arrow/Fabron _____
63. Removable Core _____	Special Keyway or Key Family Required _____
10. Signature _____	
V10** _____	
<small>** V10** is a new technology system that will be up to the type of product.</small>	
<small>** Contact factory for more information.</small>	

V10/2 Stamping Requirements	Bitting List Requirements
Keys _____	Insured Keys _____ Expanded _____
Keys with Keyset _____ Billing _____	For Expanded Billings indicate number of extra billings: _____
Blind Code _____ Oml Stamping _____	_____
Existing Die Stamp: _____	_____
New Die Stamp: _____	_____
Oml SARGENT Logo _____	_____
Oml Keyway _____	_____
Cylinders _____	_____
No Cyl Stamping _____	_____
Cyl Face _____	_____
Cyl Concealed _____	_____

Key Quantities	Number of cut Core all Keys _____	Construction Masters _____	EMK's (Total) _____
	Number of cut Master level Keys per each Master _____		
	Number of cut Change (Day) keys per Cylinder _____	QR _____	per Keyset Symbol: _____

SARGENT has created a new order lead sheet. This form must accompany any purchase order containing product for the Signature cylinders and keys.

SARGENT recommends that the form accompany any purchase order for master keyed systems.

How to Order/Special Features

Signature® Series



How to Order

In order to obtain a unique SARGENT Signature pattern, a pre-authorization form must be sent to SARGENT's Key Records department in New Haven, CT. SARGENT will reserve a specific Signature pattern for the particular end user.

All purchase orders received by SARGENT for Signature products must be accompanied by a letter of authorization from the end user, including his registered Signature pattern and 8 digit pin code.

10- option has been created to assist in identifying when a SARGENT product include the Signature cylinder feature.

When ordering, use 10- as the option to indicate that the product requires the Signature feature (e.g., 10-8226 LNL x 32D, 10-10G05 LL x 32D, etc.)

If other options are being used, be sure that the Signature option appears first (e.g., 10-63-10G05, 10-21-8226 x 32D, etc.)

Special Features: VKC and Cut Key Options

Visual Key Control

Visual Key Control will incorporate the standard industry key symbol identification. The Visual Key Control feature will appear on the key blank only. Stamping on the face of the barrel is not possible due to space limitations and security reasons. Concealed stamping of the key set on the slide is available as an option. All keys will have the Signature facility code with the Signature Quill logo.

Special Key Blank Stamping

The Signature Key Blank is offered in two versions to accommodate a variety of key bow stamping options.

Version one: The key blank has the standard SARGENT logo embossed on one side. The other side has the Signature Quill Logo, Do Not Duplicate, specific Signature code pattern, keyway and space for one additional line of stamping such as key set.

Version two: The key is less SARGENT logo. This allows for additional space for optional stamping such as custom field stamping. The other side has the Signature Quill Logo, Do Not Duplicate, specific Signature code pattern key way and one additional line for stamping such as key set.

Key set symbols or alternate symbols will be stamped on all master keyed orders.

Finish Ordered	Plug/Shell	Cylinder Housing (Mortise/Rim)
03	04	03
04		04
09		09
10		10
10B		10B
10BE		10BE
722		722

Finish Ordered	Plug/Shell	Cylinder Housing (Mortise/Rim)
14	15	14
15		15
26		26
26D		26D
32		32
32D		32D
WSP		WSP
BSP		BSP

Copyright © 2007-2024, Sargent Manufacturing Company, an ASSA ABLOY Group company. All rights reserved. Reproduction in whole or in part without the express written permission of Sargent Manufacturing Company is prohibited.

The ASSA ABLOY Group is the global leader in access solutions. Every day, we help billions of people experience a more open world.

ASSA ABLOY Opening Solutions leads the development within door openings and products for access solutions in homes, businesses and institutions. Our offering includes doors, frames, door and window hardware, mechanical and smart locks, access control and service.

SARGENT[®]
ASSA ABLOY

SARGENT Manufacturing Company
100 Sargent Drive
New Haven, CT 06511 USA
800-727-5477
www.sargentlock.com

Founded in the early 1800s, SARGENT[®] is a market leader in locksets, cylinders, door closers, exit devices, electro-mechanical products and access control systems for new construction, renovation, and replacement applications. The company's customer base includes commercial construction, institutional, and industrial markets.

Copyright © 2007-2024, SARGENT Manufacturing Company. All rights reserved. Reproduction in whole or in part without the express written permission of SARGENT Manufacturing Company is prohibited. Patent pending and/or patent www.assaabloydss.com/patents.

90105 05/24